

A FINE ADJUSTMENT DEVICE FOR USE WITH THE MICRO-DUMAS APPARATUS.

BY S. RANGASWAMI.

(From the Department of Chemistry, Andhra University, Waltair.)

Received September 20, 1938.

(Communicated by Prof. T. R. Seshadri.)

It is well known that in the determination of nitrogen in organic compounds by the method of Pregl (*Quantitative Organic Micro-Analysis* by Pregl—2nd and 3rd English editions) the accuracy of the experiment depends on the rate of combustion of the compound, which is controlled by observing the rate of entry of gas bubbles into the nitrometer past the mercury seal. To obtain a good value not only should the preliminary combustion of the compound be carried out at the optimum rate which gives rise to not more than two bubbles in every three seconds, but the subsequent washing out of the products of combustion from the combustion tube into the nitrometer by means of carbon dioxide from the Kipp should be done so carefully that a gas rate of two bubbles in three seconds is not exceeded even for a few seconds. The latter operation requires considerable experience as a higher gas rate invariably gives higher values for nitrogen than according to the theory.

For the delicate manipulation of the stop-cock in the connecting piece various devices have been tried in the past, the most satisfactory being the provision of the stop-cock with a long handle so that by the application of gentle pressure to the tip of the handle small rotations of the barrel can be effected. The cutting of shallow channels about 4 mm. long on the surface of the barrel at either end of the main bore has considerably added to the value of the long handle, and ensures accurate results to the careful and diligent worker (*loc. cit.*).

The above combination suffers from one or two drawbacks. The barrel of the stop-cock must be greased to a certain optimum extent. While over-greasing fills up part of the channel and makes the stop-cock turn round of its own accord owing to the weight of the long handle, under-greasing brings in its train a considerable amount of friction and a corresponding diminution in the benefit derived from the long handle. Further the beginner generally does not know the right amount of pressure to be applied to the tip of the handle for effecting a certain desired rotation of the barrel with

the result that the gas velocity is not completely under his control. The use of the simple device described in this paper while being considerably helpful even to the expert micro-analyst, makes the determination safe even in the hands of the beginner.

Figs. 1 and 2 give the plan and the elevation of the device which consists of an ebonite piece carrying two screws, while Figs. 3 and 4 represent the same when it is fixed on to the connecting piece. The non-tapering portion of the connecting piece can easily pass through the hole (A) and the ebonite piece fixed rigidly at any desired position on the glass part by means of the screw (B) which controls the cleft shown. The screw (C) controls the movement of the stop-cock, every forward movement tending to close the

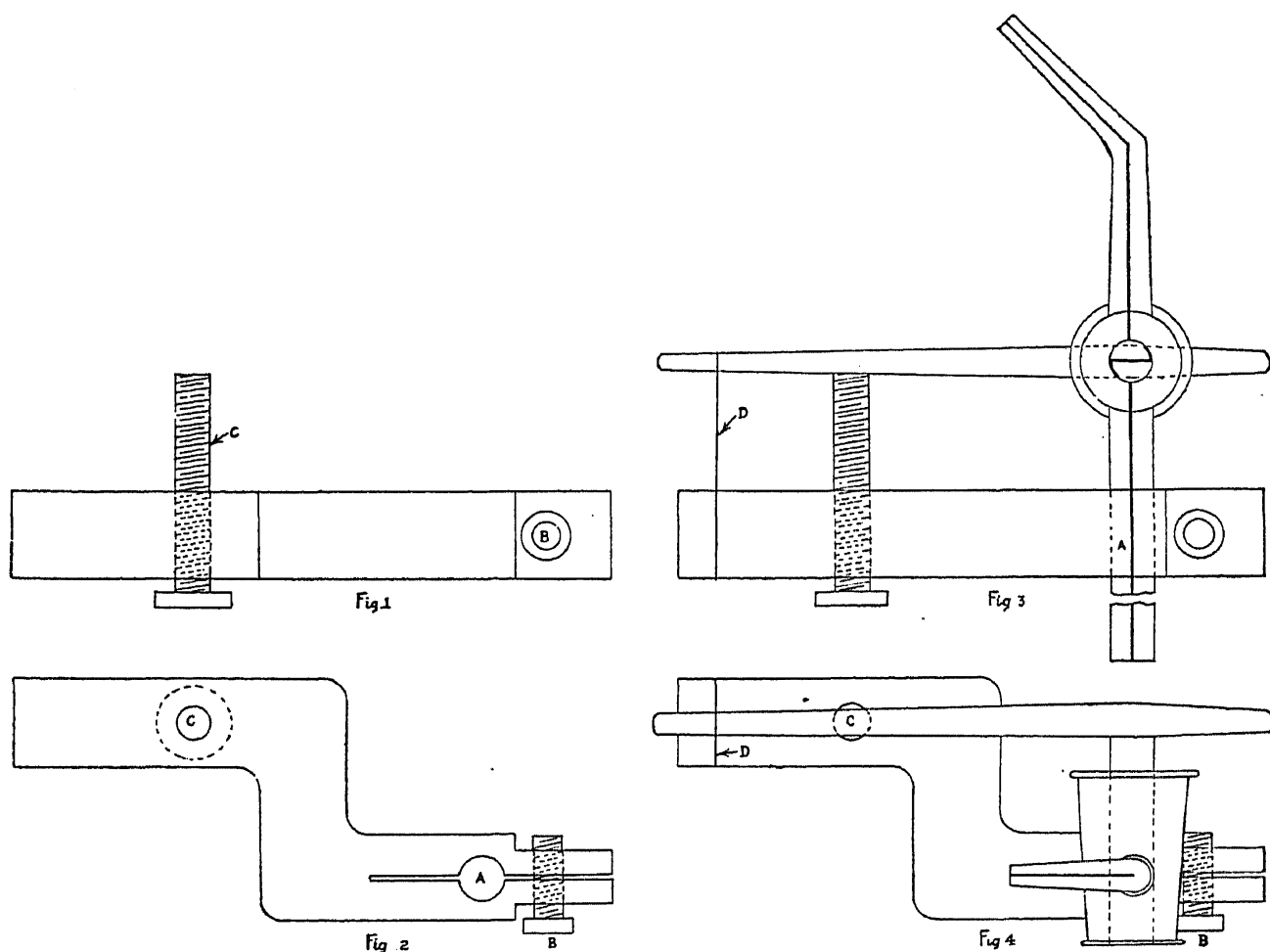

Scale 1'' = 1½''.

channel in the stop-cock while every backward movement has the opposite effect. The ebonite piece is fixed at such a position that the stop-cock is completely closed when the screw can advance no farther. By gradually working it backwards the stop-cock is gently opened by the action of the elastic band (D) and it is possible by turning the milled head of the screw by about 5 or 10° at a time to get any gas speed required. Whenever during the

course of the experiment it is necessary to have the long handle parallel to the body of the connecting piece so as to get a straight passage for the gas, the band can be slipped off and the handle taken to any desired position.

The device has been tested in a number of estimations and found very satisfactory. It is easily fixed to the connecting piece and any desired gas speed obtained and maintained without any difficulty. There is no strain on any part of the apparatus because of the shape of the ebonite piece the weight of which is small. The part is easy to construct and costs little. It was made in the Instruments Section of this University.

The author's thanks are due to Dr. G. Gangadharam for the drawings.