

# Mobility and stochastic resonance in spatially inhomogeneous systems

Debasis Dan,<sup>1,\*</sup> Mangal C. Mahato,<sup>2</sup> and A. M. Jayannavar<sup>1,†</sup>

<sup>1</sup> Institute of Physics, Sachivalaya Marg, Bhubaneswar 751005, India

<sup>2</sup> Department of Physics, Guru Ghasidas University, Bilaspur 495009, India

The mobility of an overdamped particle, in a periodic potential tilted by a constant external field and moving in a medium with periodic friction coefficient is examined. When the potential and the friction coefficient have the same periodicity but have a phase difference, the mobility shows many interesting features as a function of the applied force, the temperature, etc. The mobility shows stochastic resonance even for constant applied force, an issue of much recent interest. The mobility also exhibits a resonance like phenomenon as a function of the field strength and noise induced slowing down of the particle in an appropriate parameter regime.

P. A. C. S: 82.20.Mj; 05.40.+j; 05.60.+w; 02.50.Ey

Keywords: Stochastic resonance; Inhomogeneous medium; Mobility; Noise induced stability.

## I. INTRODUCTION

The simple phenomenon of stochastic resonance (SR) has been an active field of research for more than one and a half decades. Its appeal to natural processes has generated a lot of interest among workers from various branches of science and engineering [1]. This interest is largely because of the fact that in this phenomenon noise plays a useful role. The presence of noise helps in improving the quality of response of a system subject to an alternating external field. The conventional SR is all about the (output signal-to-noise ratio) optimization of an input signal by noisy nonlinear systems by suitably tuning the noise level. It is reflected as a peak in the output signal-to-noise ratio as a function of input noise strength. To observe SR one requires three basic ingredients (i) an energetic activation barrier, (ii) a weak coherent input periodic signal, and (iii) a source of noise. Attempts are being made to reduce the number of constraints for the realization of SR. In our present work, we are interested in the response optimization, in the presence of a non-oscillating external signal.

There was a suggestion that SR could be observed in the drift velocity of an overdamped Brownian particle in a tilted periodic potential [2]. The suggestion was an important one for it sought to do away with the oscillating input signal, considered to be an essential ingredient for the observability of the phenomenon of SR, and replace it with a constant uniform external field. Though the suggestion has now been proved to be incorrect [3,4] for overdamped particles, it is argued to be correct for underdamped particles [5] where the inertia of the particles could act as surrogate to the external oscillating field in a periodic potential. The present work shows that SR can indeed be observed in the drift velocity of overdamped particles in a periodic potential subjected to non-oscillating uniform constant field but in a medium where the particles experience spatially periodic frictional drag.

The variation of space dependent friction  $\eta(q)$  ( in the absence of spatial variations in

temperature) influences the dynamics of the particles in a potential field and helps the system to approach towards its equilibrium or steady state. The relative stability of the competing states is governed by the individual Boltzmann factor, i.e inhomogeneity in friction does not affect the stationary ( equilibrium) properties of a system but it does affect the dynamical ( nonequilibrium) properties such as the relaxation rates. In contrast, temperature inhomogeneity, changes the relative stability of the otherwise locally stable states ( thereby creating new steady states). Moreover, the relative stability of the system in two different local minima depends sensitively on the temperature profile along the entire pathway connecting the two local minima. Temperature nonuniformity together with spatially varying friction coefficient or alone has been shown to give rise to a net current in a periodic potential [6–11] in the absence of an applied bias. Spatially varying friction coefficient,  $\eta(q)$  of the medium, alone, however cannot give the net probability current  $j$  in such a potential. But when, in addition, a constant force  $F$  is applied a finite net current may result at a constant temperature  $T$  of the medium. We consider a sinusoidal potential with period  $2\pi$  and a sinusoidally varying model friction coefficient of the same period but with a phase difference  $\phi$  and modulating amplitude  $\lambda$ . The mobility [6,12]  $\mu$  ( $= \langle \frac{dq}{dt} \rangle / F = \frac{2\pi j}{F}$ , where  $\langle \frac{dq}{dt} \rangle$  is the average drift velocity of the particles) shows very interesting behaviour in the parameter space of  $(T, F, \lambda, \phi)$ . Apart from the above mentioned SR as a function of noise, the mobility also exhibits resonance like phenomenon as a function of  $F$  and the phenomenon of noise-induced stability etc.

Before we present the results of our calculation in section 3 we discuss the necessary formalism in section 2. We summarize our work in the last section 4, with discussion.

## II. THE MOBILITY

The motion of an overdamped particle, in a potential  $V(q)$  and subject to a space dependent friction coefficient  $\eta(q)$  and an additional constant force field  $F$ , at temperature  $T$ , is described by

the Langevin equation [9,10,12,13].

$$\frac{dq}{dt} = -\frac{(V'(q) - F)}{\eta(q)} - k_B T \frac{\eta'(q)}{\eta(q)^2} + \sqrt{\frac{k_B T}{\eta(q)}} \epsilon(t). \quad (1)$$

Here  $\epsilon(t)$  is the randomly fluctuating Gaussian noise term with the property

$$\begin{aligned} \langle \epsilon(t) \rangle &= 0, \\ \langle \epsilon(t)\epsilon(t_1) \rangle &= 2\delta(t - t_1), \end{aligned}$$

where  $\langle .. \rangle$  denotes average over the distribution of the fluctuating quantity  $\epsilon(t)$ . The primes in Eqn. (1) denote derivative with respect to the space variable  $q$ . Eqn. (1) has been derived earlier using microscopic treatment of system-bath coupling [10,13]. It should be noted that the above equation involves a multiplicative noise with an additional temperature dependent drift term. The additional term turns out to be essential in order for the system to approach the correct thermal equilibrium state. The motion is equivalently described by the Fokker-Planck equation [7,10,13,14].

$$\frac{\partial P(q, t)}{\partial t} = \frac{\partial}{\partial q} \frac{1}{\eta(q)} [k_B T \frac{\partial P(q, t)}{\partial q} + (V'(q) - F)P(q, t)]. \quad (2)$$

The stationary probability current  $j$ , for periodic  $V(q)$  and  $\eta(q)$  with the same periodicity  $2\pi$ , is given as [6,12]

$$j = \frac{k_B T (1 - e^{-\frac{2\pi F}{k_B T}})}{\int_0^{2\pi} e^{-\frac{-V(y)+Fy}{k_B T}} dy \int_y^{y+2\pi} \eta(x) e^{\frac{V(x)-Fx}{k_B T}} dx}, \quad (3)$$

and the corresponding mobility [6,12]  $\mu = \frac{2\pi j}{F}$ . Clearly  $j \rightarrow 0$  as  $F \rightarrow 0$ , but  $\mu$  remains finite for finite temperature  $T$ . The mobility in this linear response regime [12] is given by

$$\lim_{F \rightarrow 0} \mu = \frac{(2\pi)^2}{\int_0^{2\pi} dy e^{-\frac{-V(y)}{k_B T}} \int_y^{y+2\pi} dx \eta(x) e^{\frac{V(x)}{k_B T}}}. \quad (4)$$

Notice that the above expression for  $\mu$  involves a combination of  $\eta(x)$  and  $V(x)$  which contribute in different ways and cannot be accounted for by a single "effective" potential. We would like to point out that a particle in a medium, with space dependent temperature profile, experiences an effective

potential ( or net force). This in turn, is able to shift the stable points and introduces noise induced transitions [6]. In our present work we emphasize that the space dependent friction influences the kinetic properties of the system and unlike in the case of space-dependent temperature we do not have a net additional force in the steady state.

In the absence of any external periodic potential the drift velocity is linear in  $F$  and the corresponding mobility is given by  $\mu = \frac{1}{\bar{\eta}}$ , where  $\bar{\eta} = \frac{1}{2\pi} \int_y^{y+2\pi} \eta(x) dx$ , is the average value of the friction coefficient over a period. The above result follows from straight forward mathematical analysis. From Eqn. (3) one can see that the magnitude of  $\mu$  depends sensitively on the potential and the frictional profile over the entire period. And it can be much larger or smaller than the mobility of a particle moving in a homogeneous medium with friction coefficient equal to  $\bar{\eta}$ . Depending on the temperature and the applied field, mobility can in fact be much larger than the asymptotic mobility ( with respect to  $F$  and  $T$ ). This implies that at some particular values of  $F$  and  $T$  the mobility, in the absence of periodic potential is much smaller than in the presence of periodic potential. This counter-intuitive result emerges because of the complex manner in which the phase shift between the potential and the frictional profile, the amplitude of the friction coefficient, etc, influence the mobility. We consider for our calculation,

$$V(q) = -\sin q, \tag{5}$$

$$\eta(q) = \eta_0(1 - \lambda \sin(q + \phi)), \tag{6}$$

with  $0 \leq \lambda < 1$  so that  $\bar{\eta} = \eta_0$ . One can easily see that for  $F < 1$ , as  $T \rightarrow 0$ ,  $\mu \rightarrow 0$ . Also, as  $F, T \rightarrow \infty$ ,  $\mu \rightarrow \frac{1}{\eta_0}$ . Moreover,  $j(F) \neq -j(-F)$ , except when  $\phi = 0$  and  $\pi$ , and hence mobility is asymmetric with respect to the force. For intermediate values of  $T$  and  $F$  one needs to evaluate the double integral in the denominator of Eqn. (3) numerically [15] and explore the variation of  $\mu$  :

$$\eta_0 \mu = \frac{2\pi k_B T (1 - e^{\frac{-2\pi F}{k_B T}})}{F \int_0^{2\pi} e^{\frac{(\sin y + Fy)}{k_B T}} dy \int_y^{y+2\pi} (1 - \lambda \sin(x + \phi)) e^{\frac{-\sin x - Fx}{k_B T}} dx} . \tag{7}$$

We calculate  $\mu$  in various sections of the parameter space of  $(T, F, \lambda, \phi)$ . Henceforth we have scaled mobility, temperature and force to dimensionless units as in Ref. [12].

### III. RESULTS.

The mobility  $\mu$  shows many interesting features even at  $T = 0$ . At  $T = 0$ , following Ref. [12] closely,  $\mu$  remains zero for  $|F| \leq 1$  for all values of  $\phi$  and  $\lambda$ . However,  $\phi$  and  $\lambda$  play important role for  $|F| > 1$  and the mobility is given by

$$\eta_0\mu = \frac{\frac{1}{F}(1 - \frac{1}{F^2})^{1/2}}{\frac{1}{F} + \lambda(1 - \sqrt{1 - \frac{1}{F^2}}) \sin \phi}. \quad (8)$$

For applied fields smaller than the critical field ( $F = 1$ ) the particle remains in a locked state or confined to the local minima of the potential. For  $F > 1$  (i.e, when the potential barrier for motion does not exist) the particle moves down the potential slope or will be found in a running state [5,12]. Observe that at  $T = 0$ ,  $\mu(F, \phi) = \mu(-F, -\phi)$  and this happens to be true for  $T \neq 0$  as well. We may roughly divide the full range of  $\phi$  (0-2 $\pi$ ) into two regions where  $\mu$  shows qualitatively distinct features [Fig. (1)].

From Fig. (1a) we observe that for  $F > 1$ ,  $0 \leq \phi \leq \pi$ ,  $\eta_0\mu$  always remain less than one but approaches one asymptotically as  $F \rightarrow \infty$ . Fig. (1b) shows that in the range  $\pi < \phi < 2\pi$ ,  $\eta_0\mu$  could even be larger than one for large  $\lambda$  and exhibits a maximum. This occurrence of maxima is a new feature and could only be ascribed to the space dependence of friction coefficient  $\eta(q)$ . It is to be noted that the value of the mobility at the maxima is always larger than the asymptotic mobility ( $\frac{1}{\eta}$ ). In Fig. (2) we have given a surface plot of the mobility obtained from Eqn. (8) as a function of  $F$  and  $\phi$ . This figure clearly shows that there is a small region in  $\phi$ , around  $1.2\pi$  where the maxima can be observed, elsewhere mobility monotonically increases with  $F$ . In contrast, in a medium with a space independent friction, the mobility in the high friction limit monotonically increases with  $F$

for all values of  $T$  and asymptotically goes to one [12]. For given  $F > 1$ , however from Eqn. (8), maximum occurs at  $\phi = \frac{3\pi}{2}$  and minimum at  $\phi = \frac{\pi}{2}$ . It should be noted, that the space dependence of the friction coefficient does not alter the threshold value ( $F = 1$ ) for nonzero mobility.

As the temperature  $T$  is increased from zero, the thermal fluctuations make the current  $j$  nonzero even for  $|F| < 1$ , when the barrier to free passage motion is nonzero. For  $T \neq 0$ , as  $F \rightarrow 0, j \rightarrow 0$  linearly with  $F$  but the mobility remains finite [Eqn. (4)]. For a given temperature  $T \neq 0$  and when the field is very high, the effect of the periodic potential vanishes and consequently  $\eta_0\mu \rightarrow 1$ . However in the small  $F$  regime  $\eta_0\mu$  can be much larger than one, leading to a peak as a function of  $F$  depending on the parameter values of  $\phi, \lambda, T$ . The resonance feature as a function of  $F$  can also be observed at finite temperatures, as shown in Fig. (3).

Let us now examine the variation of  $\eta_0\mu$  as a function of the modulation parameter  $\lambda$  of the friction coefficient. Fig. (4) shows the variation of  $\eta_0\mu$  for  $\phi = 0$  at fixed  $T = 2.0$  and Fig. (5) for  $\phi = \pi$  at the same  $T$  ( For  $\phi = 0$  and  $\pi$ ,  $\eta_0\mu$  is symmetric about  $F = 0$ ). When  $V(q)$  and  $\eta(q)$  are in phase, the mobility monotonically decreases with  $\lambda$  ( $F = 0$  having the least value at  $\lambda = 1$ ) whereas when they are in opposite phase mobility increases with  $\lambda$ . For  $\phi = \pi$  and large  $\lambda$  ( Fig. [5]),  $\eta_0\mu$  becomes larger than one for all values of  $F$ . Figures (4 and 5) essentially corroborate the observations made in Ref. [16] that when  $\phi = 0$  the friction coefficient is the largest at the positions where the particle has the largest acquired velocity due to the potential, and it is smallest where the particle has the smallest velocity. Thus the damping term has the severest effect of slowing down the particle. When  $\phi = \pi$  the situation is just the opposite. In this case the frictional effect is the least. In fact it has a positive effect and as can be seen from Fig. (5) the mobility  $\eta_0\mu$  even becomes larger than one. For any other  $\phi$ , however, the situation is complicated to analyze as simply. To emphasize this we have given a surface plot of  $\eta_0\mu$  with  $\lambda$  and  $\phi$  in Fig. (6) for  $T = 2.0$  and  $F = 0.8$ . Mobility increases monotonically with  $\lambda$  in a region for  $\phi$  around  $1.1\pi$ , and elsewhere it decreases

monotonically.

We now discuss the variation of  $\eta_0\mu$  as a function of temperature  $T$  ( or the noise strength). At this point it is pertinent to note that there has been discussion in literature about the motion of an underdamped particle, in tilted ( due to a constant force  $F$ ) but otherwise periodic potentials, being in two states depending on the value of  $F$  and the damping constant  $\eta_0$  of the medium [5,12]. The particle could be in a locked state ( remaining confined to a local minimum of the potential) or in a running state ( corresponding to a motion down the potential slope). The two states could also coexist even for  $|F| < 1$  ( for periodic potential  $V(q)$  as given in Eqn. (5) ). However, in the overdamped case at  $T = 0$  the particle can be either in the locked state (for  $|F| < 1$ ) or in the running state( for  $|F| > 1$ ). But as  $T$  is increased the particle incoherently hops from one stable ( locked state) to another one even for  $|F| < 1$ , leading to a net current. When in addition, we consider the friction coefficient to be space dependent, the mobility as a function of temperature shows many more interesting features depending on the values of  $F$ ,  $\lambda$  and  $\phi$ . We confine our attention to large values of  $\lambda$  ( but  $< 1$ ), for example,  $\lambda = 0.9$ .

In the entire range of  $\phi[0 < \phi < 2\pi]$  we present results for a few typical values of  $\phi$ .

Fig. (7a) shows the nature of SR at  $\phi = 0.9\pi$  for arbitrarily selected values of  $F$ . We see that for some values of  $F$ , especially for  $F < 1$ ,  $\eta_0\mu$  becomes larger than one at intermediate values of  $T$  ( the peaks appear at larger  $T$  for larger  $F$ ) and asymptotically tends to one as  $T \rightarrow \infty$ , for all values of  $F$ . We find SR even for  $F \rightarrow 0$  and in fact the peak mobility is larger for  $F < 1$  than for  $F > 1$ . Similar behaviour could be seen for  $\phi < 0.9\pi$  also. These peaks for small  $\phi$ , however, are very broad. Fig. (7b) is for  $\phi = 1.44\pi$ . In this figure the peaks are sharper for larger values of  $F$  ( $F > 1$ ) and the peaks disappear for  $F < 1$ . The temperature  $T(= T_p)$  corresponding to the peak value of mobility is much lower than that in the previous case ( $\phi = 0.9\pi$ ) and unlike the previous case it decreases and tends to zero as  $F$  is increased. Figs. (7a) and (7b) clearly exhibits



the occurrence of SR for  $F < 1$  as well as for  $F > 1$ . It should be noted that we observe stochastic resonance for smaller values of  $\lambda (< 0.9)$  too. But as  $\lambda$  is decreased the peaks become less prominent and the range of  $\phi$  over which the phenomena could be observed shrinks and finally disappears.

We now turn to examine the location of maxima  $T_P$ , as a function of system parameters. In Fig. (8) we have plotted  $T_P$  against  $\phi$  for various values of  $F$ , the inset shows the variation of  $T_P$  versus  $F$  for some typical values of  $\phi$  as indicated on the figure. For small fields  $F < 1$ ,  $T_P$  versus  $\phi$  is a non-monotonic function exhibiting a minima, which shift towards higher values of  $\phi$  as  $F$  as increased. As we go away from the minima on both sides, the resonance behaviour becomes more broader. For  $\phi$  beyond  $1.5\pi$ , mobility does not show a maxima( or  $T_P$ ). For values of field larger than about 1.2,  $T_P$  decreases monotonically with  $\phi$ .  $T_P$  shows a monotonic or a non-monotonic behaviour as a function of  $F$  as can be seen from the inset of Fig. (8). This behaviour is very sensitive to material parameters. In Fig. (9) we have given a surface plot of the mobility as a function of  $\phi$  and  $T$  for  $F = 0.5$  and  $\lambda = 0.9$ . For values ranging from  $\phi = 0.9\pi$  to  $1.44\pi$  we obtain SR in the mobility as a function of temperature. It is to be noted that this surface plot as well as all the earlier surface plots exhibit a maxima in the mobility as a function of  $\phi$  for a given temperature  $T$  and field strength  $F$ , on the other hand the mobility shows a monotonic behaviour with  $\lambda$  (see for example Fig. (6)). This seems to suggest that  $\phi$  may play the characteristic role of frequency in our model in the absence of additional external frequency signal [5,17].

Fig. (10a) is for  $\phi = 1.5\pi$ . For forces less than a certain  $F$  (closer to the critical value of  $F = 1$ ) all curves begin with  $\eta_0\mu$  less than one and gradually increase with  $T$  and asymptotically reach the value one. And for larger forces the mobility always remain larger than  $\eta_0\mu = 1$  and asymptotically reach one as  $T \rightarrow \infty$ . For large values of  $F(> 1)$ , for which the potential barrier for motion has already disappeared, the mobility decreases as  $T$  is increased from  $T = 0$ . This implies that the motion of the overdamped particle becomes more sluggish than at  $T = 0$ , where one would

have expected the particle to become more mobile as  $T$  is increased from zero. Our observation indicates that the presence of noise actually slows down the motion of deterministically overall unstable states in the appropriate range of  $F$  and  $\phi$ . This is somewhat akin to the phenomenon of noise-induced stability of unstable states [18–21]. For the values of  $F$  larger than the critical field, the barrier to the motion of the particle disappears and in this case ( depending on the system parameters) the noise slows down the motion between unstable states whereas for  $F < 1$  the noise helps to overcome the potential barrier for the passage of the particle. And finally in Fig. (10b), for  $\phi = 1.6\pi$ , we observe some very interesting features that are somewhat contrary to common expectations. Values of  $F$  very close to ( but larger than the critical value one), the mobility attains a minimum value and then begins to increase with  $T$  and finally reaches  $\eta_0\mu = 1$ , asymptotically, as  $T \rightarrow \infty$ . In this case we observe a cross-over from the regime of noise-induced slowing down to the noise-enhanced mobility for a given  $F$  as a function of the temperature (noise strength). All these interesting features ( some of them even counterintuitive) described above, results from a subtle combined effect of the periodic space dependent friction and the periodic potential in the presence of a constant applied force. The phase difference  $\phi$  between the potential and the friction coefficient plays a crucial role in determining their nature.

#### IV. SUMMARY AND DISCUSSION

We have theoretically studied the motion of an overdamped particle in a tilted( by a constant force) but otherwise sinusoidal potential in an inhomogeneous medium. We considered the particle to experience a sinusoidally varying friction coefficient while in motion, but the temperature of the medium is kept uniform . The behaviour of the motion of the particle characterized by its mobility, is influenced by the phase difference between the potential function and the friction coefficient in important ways. If the friction coefficient is small where the potential is high, then the bias  $F$  will

influence the mobility differently than when the friction coefficient is large where potential is high. By choosing the phase difference suitably the mobility could be enhanced by tuning the noise level ( temperature) of the system or lowered depending on the value of the phase difference. The former indicating the occurrence of stochastic resonance in the motion of the overdamped particle in a periodic potential with the application of a non-oscillating constant field. The decrease of mobility, on the other hand, indicates that the motion could be made sluggish by enhancing the noise level ( temperature). We have also observed the peaking behaviour in the mobility as a function of applied field. Of course, both these effects cannot be seen in a homogeneous medium with constant friction coefficient and uniform temperature.

At this point it is worthwhile to note that in the conventional treatment on SR it has been established that SR occurs when Kramer's time of barrier passage roughly matches the ( dominant characteristics) time scale of the input ( externally applied) signal. But in the present work there is no time varying externally applied input signal and hence the criterion for the occurrence of SR is not satisfied. However some recent works have shown that the SR can also occur in the absence of an external periodic force, which is a consequence of the intrinsic dynamics of the nonlinear system [22,23]. Such a behaviour has been described as autonomous SR. It may also be possible that the SR phenomena that we have discussed, may be a little closer to dither( or threshold SR) .

In this system, that we study, the current is in general asymmetric with respect to the reversal of the direction of the applied force. This result has earlier been used to obtain a net unidirectional motion in the presence of time oscillating field, but with net average force zero( i.e without an obvious bias) [24].

## ACKNOWLEDGEMENT

MCM thanks the Institute of Physics, Bhubaneswar, for financial assistance and hospitality.

MCM and AMJ acknowledge partial financial support from the B. R. N. S. / D. A. E. , India.

## REFERENCES

---

\* dan@iopb.res.in

† jayan@iopb.res.in

- [1] L. Gammaitoni, P. Hänggi, P. Jung and F. Marchesoni. Rev. Mod. Phys. **70**, 223 (1997).
- [2] G. Hu, Phys. Lett. A **174**, 247 (1993).
- [3] M. Gitterman, I. B. Khalfin and B. Ya. Shapiro. Phys. Lett. A **184**,339 (1994).
- [4] J. M. Casado, J. J. Mejias and M. Morillo. Phys. Lett. A **197** , 365 (1994).
- [5] F. Marchesoni, Phys. Lett. A **231**, 61 (1997).
- [6] M. Büttiker, Z. Phys. B **68**, 161 (1987).
- [7] N. G. van Kampen, IBM. J. Res. Develop **32**, 107 (1988).
- [8] M. M. Millonas, Phys. Rev. Lett **74**, 10 (1995).
- [9] A. M. Jayannavar, Phys. Rev. E **53**, 2957 (1996).
- [10] M. C. Mahato, T. P. Pareek and A. M. Jayannavar, Int. J. Mod. Phys B **10**, 3857 (1996).
- [11] R. Rozenfeld, J. Luczka and P. Talkner, Physics Letters A **249** , 409 (1998).

- [12] H. Risken, *The Fokker Planck Equation* (Springer Verlag, Berlin , 1984).
- [13] A. M. Jayannavar and M. C. Mahato, *Pramana- J. Phys* **45**, 369 (1995).
- [14] N. G. van Kampen. *Stochastic Processes in Physics and Chemistry* , North Holland, (1992).
- [15] The integrator used here (DCUHRE) has been taken from Alan Genz's home page  
<http://www.math.wsu.edu/math/faculty/genz/homepage>.
- [16] C. M. Falco, *Am. J. Phys.* **44**, 733 (1976).
- [17] Y. W. Kim and W. Sung, *Phys. Rev. E* **57**, R6237 (1998).
- [18] I. Dayan, M. Gitterman and G. H. Weiss, *Phys. Rev. A* **46**, 757 (1991).
- [19] R. N. Mantegna and B. Spagnolo, *Phys. Rev. Lett* **76**, 563 (1996).
- [20] M. C. Mahato and A. M. Jayannavar, *Mod. Phys. Lett B* **11**, 815 (1997).
- [21] M. C. Mahato and A. M. Jayannavar, *Physica A* **248**, 138( 1998).
- [22] J. L. Cabrera, J. Gorrongoita and F. J. Rubia, *Phys. Rev. Lett.* **82**, 2816 (1999).
- [23] H. Gang, T. Ditzinger, C. Z. Ning and H. Haken, *Phys. Rev. Lett.* **71**, 807, (1993).
- [24] J. D. Bao, Y. Abe, Y. Z. Zhao, *Phys. Rev. E* **58**, 293 (1998).

## FIGURE CAPTIONS .

FIG. 1. Mobility  $\eta_0\mu$  as a function of  $F$  at  $T = 0$  for various values of  $\lambda$  (all in dimensionless units ) for (a)  $\phi = 0.9\pi$ , (b)  $\phi = 1.2\pi$ .

FIG. 2. Surface plot of Mobility at  $T = 0$  as a function of  $F$  and  $\phi$  at  $\lambda = 0.9$ .  $\phi$  is in units of  $2\pi$ .

Fig. 3. Surface plot of mobility  $\eta_0\mu$  as a function of applied bias  $F$  and  $\phi$  at  $T = 0.8$  and  $\lambda = 0.9$ .  $\phi$  is in units of  $2\pi$ .

FIG. 4. Mobility  $\eta_0\mu$  as a function of  $\lambda$  at  $T = 2.0$  and  $\phi = 0$  for various values of  $F$  .

FIG. 5. Mobility  $\eta_0\mu$  as a function of  $\lambda$  at  $T = 2.0$  and  $\phi = \pi$  for various values of  $F$  .

FIG. 6. Surface mobility as a function of  $\lambda$  and  $\phi$  at  $F = 0.5$  and  $T = 2.0$ , to highlight the monotonic behaviour of mobility with  $\lambda$ .

FIG. 7. Mobility  $\eta_0\mu$  as a function of temperature  $T$  at  $\lambda = 0.9$  for various values of  $F$  for (a)  $\phi = 0.9\pi$  (b)  $\phi = 1.44\pi$  . The insets highlight the maxima in the curves.

Fig. 8. Temperature corresponding to the peak mobility ( $T_P$ ) as a function of  $\phi$  ( in units of  $2\pi$  ) for various values of  $F$ . The inset shows the variation of  $T_P$  as a function of  $F$  for various values of  $\phi$ .

Fig. 9. Surface plot of mobility  $\eta_0\mu$  as a function of temperature  $T$  and  $\phi$  at  $F = 0.5$  and  $\lambda = 0.9$ .  $\phi$  is in units of  $2\pi$ .

FIG. 10. Mobility  $\eta_0\mu$  as a function of temperature  $T$  at  $\lambda = 0.9$  for various values of  $F$  for (a)  $\phi = 1.5\pi$  (b)  $\phi = 1.6\pi$ . The inset of figure (b) highlights the minima in mobility.

FIG. 1.

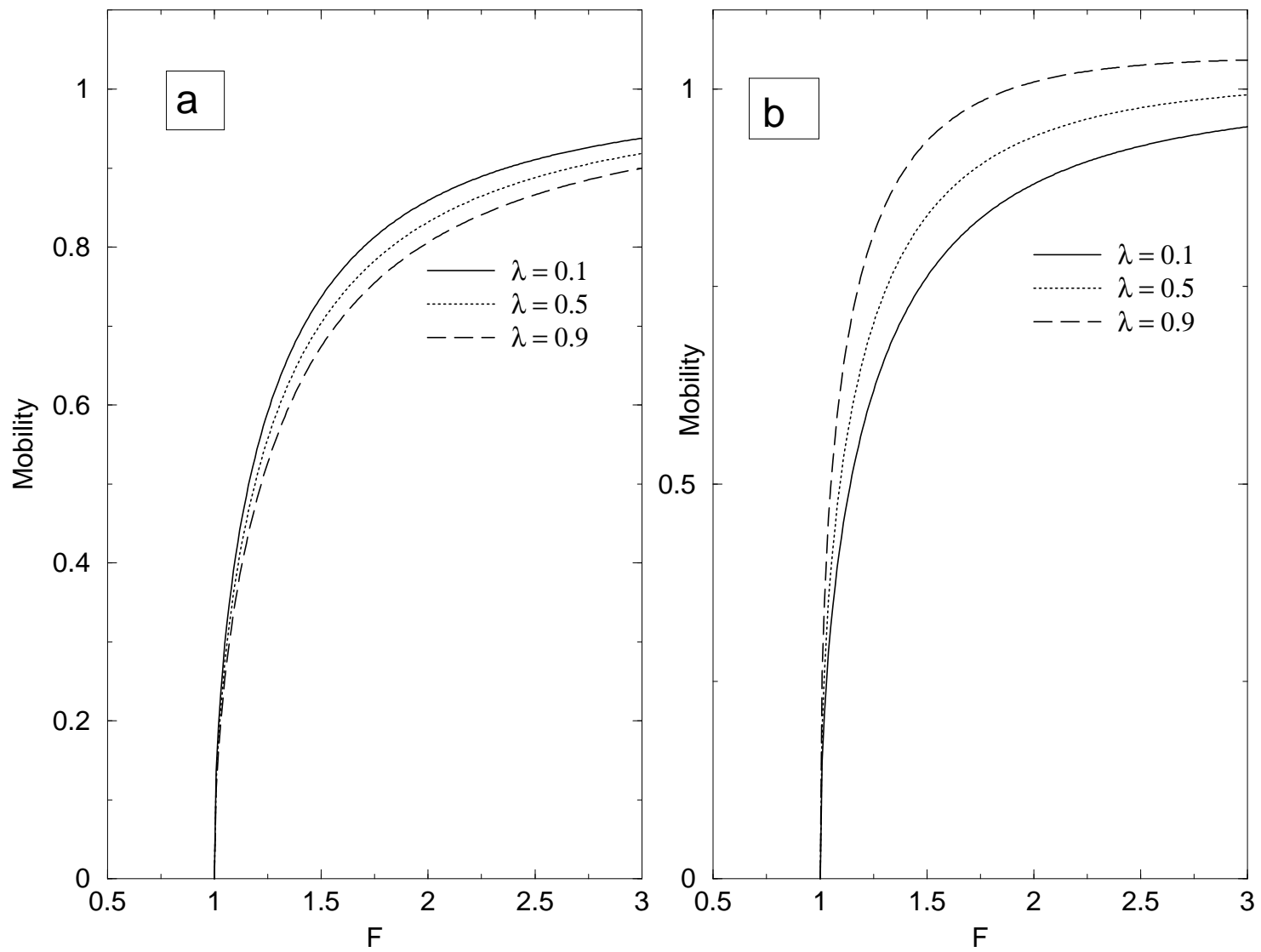

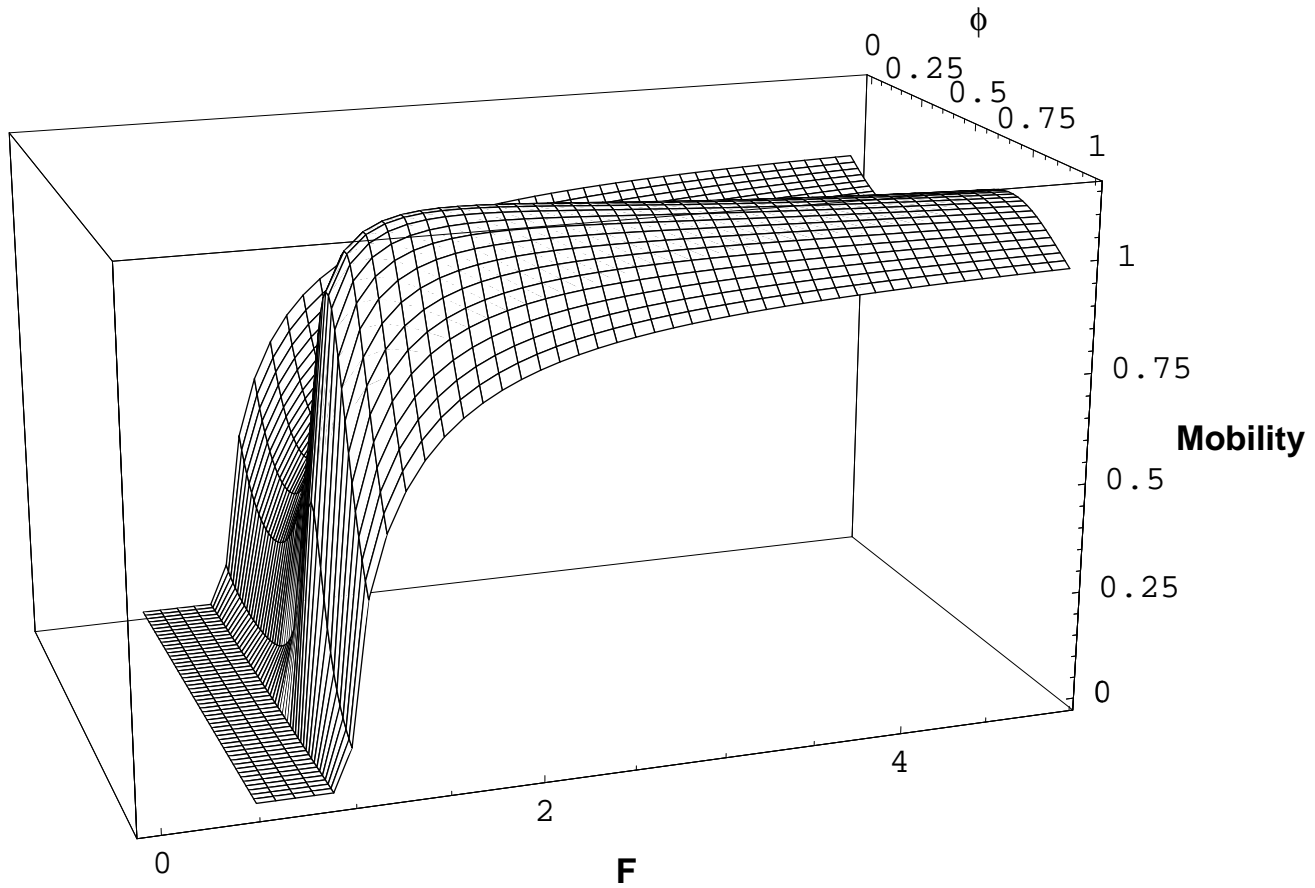

FIG. 2.



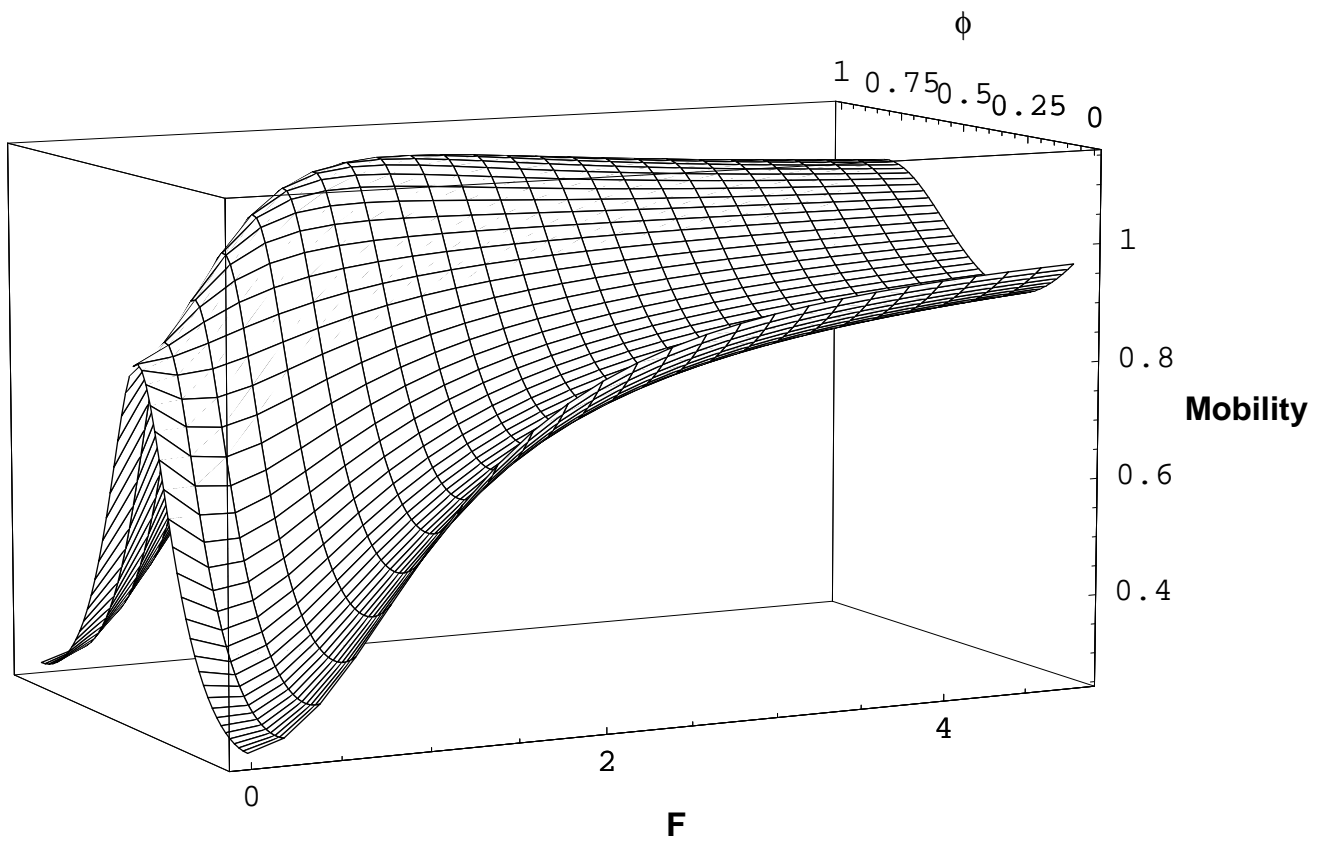

FIG. 3.

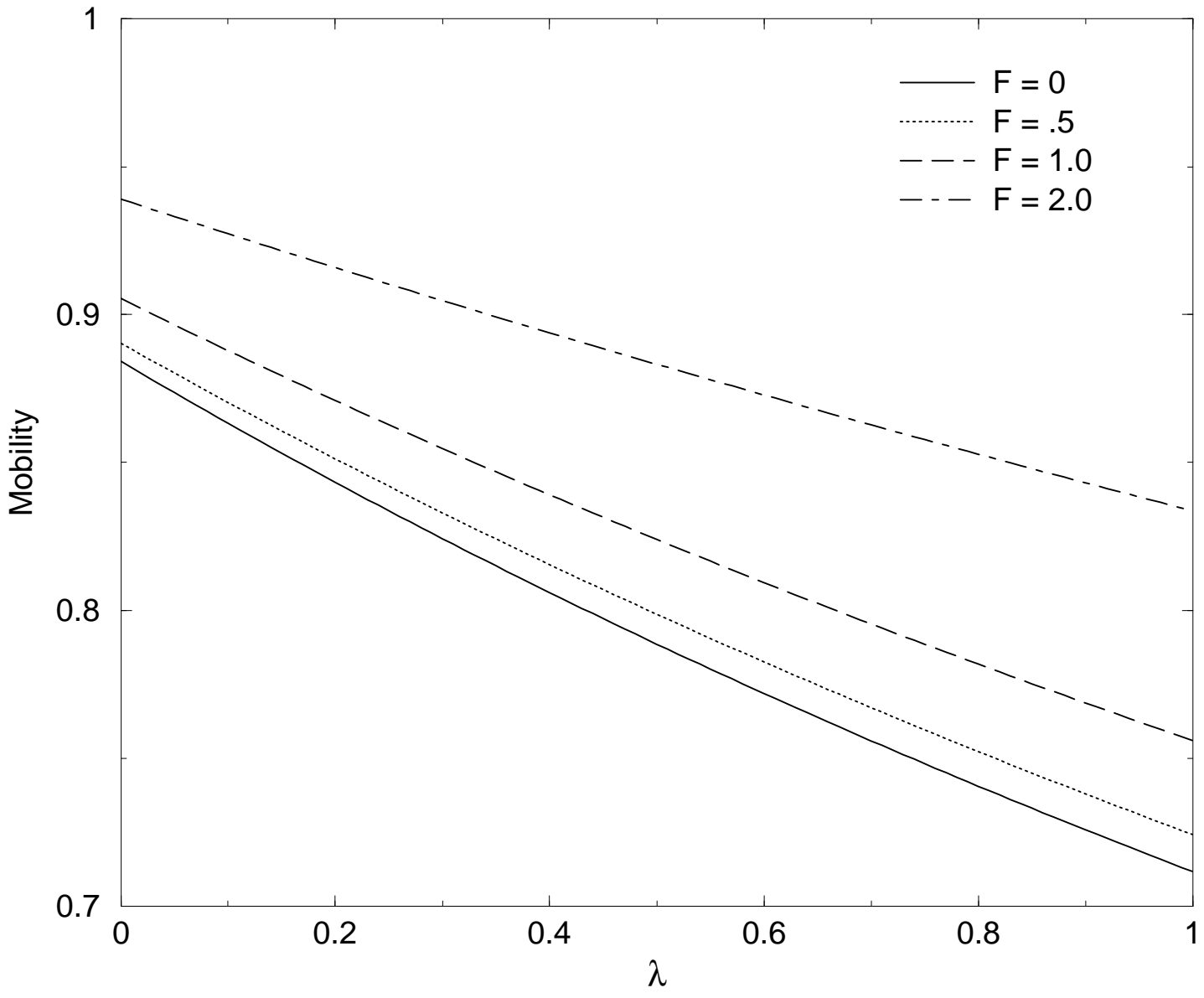
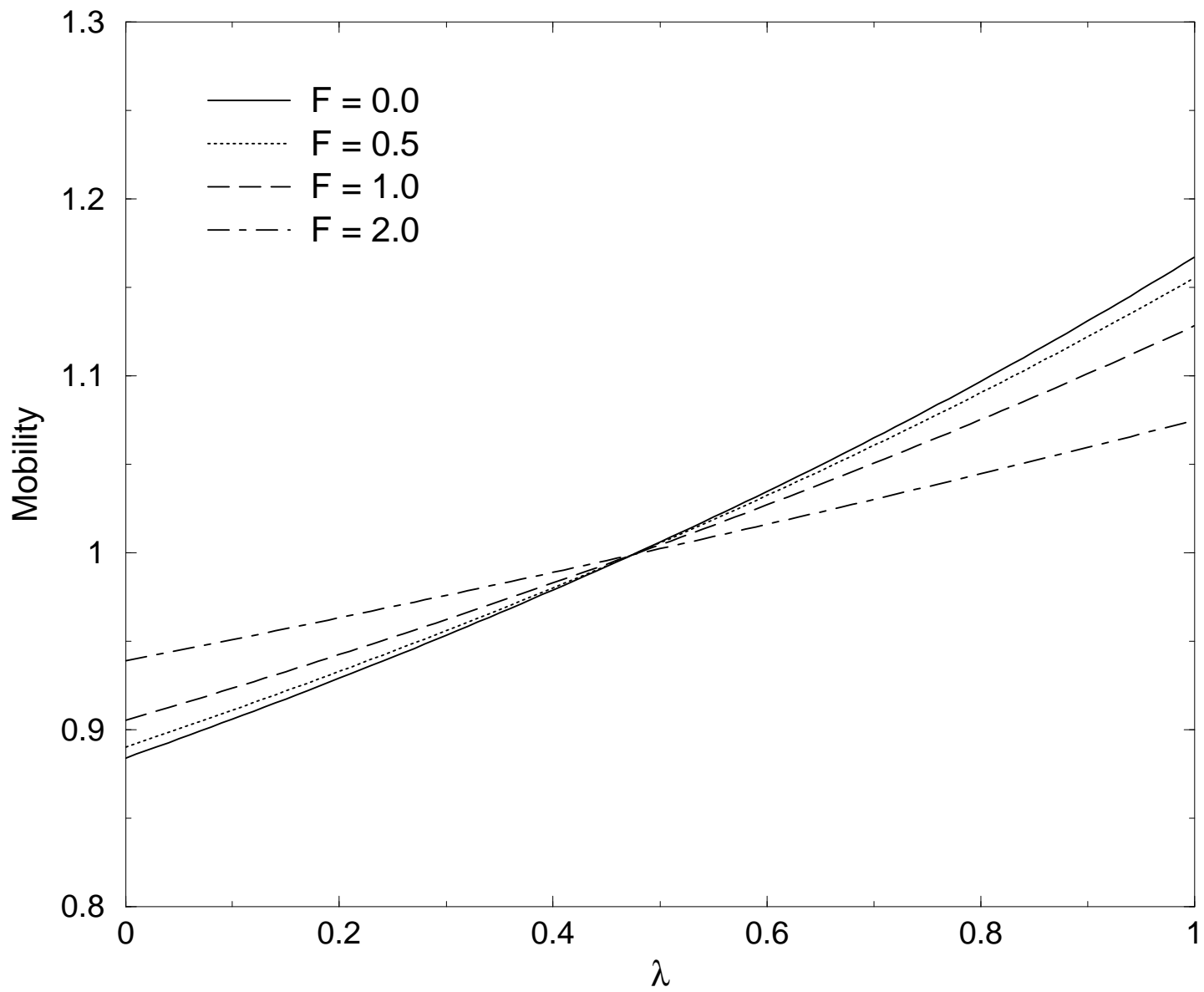

FIG. 4.

FIG. 5.



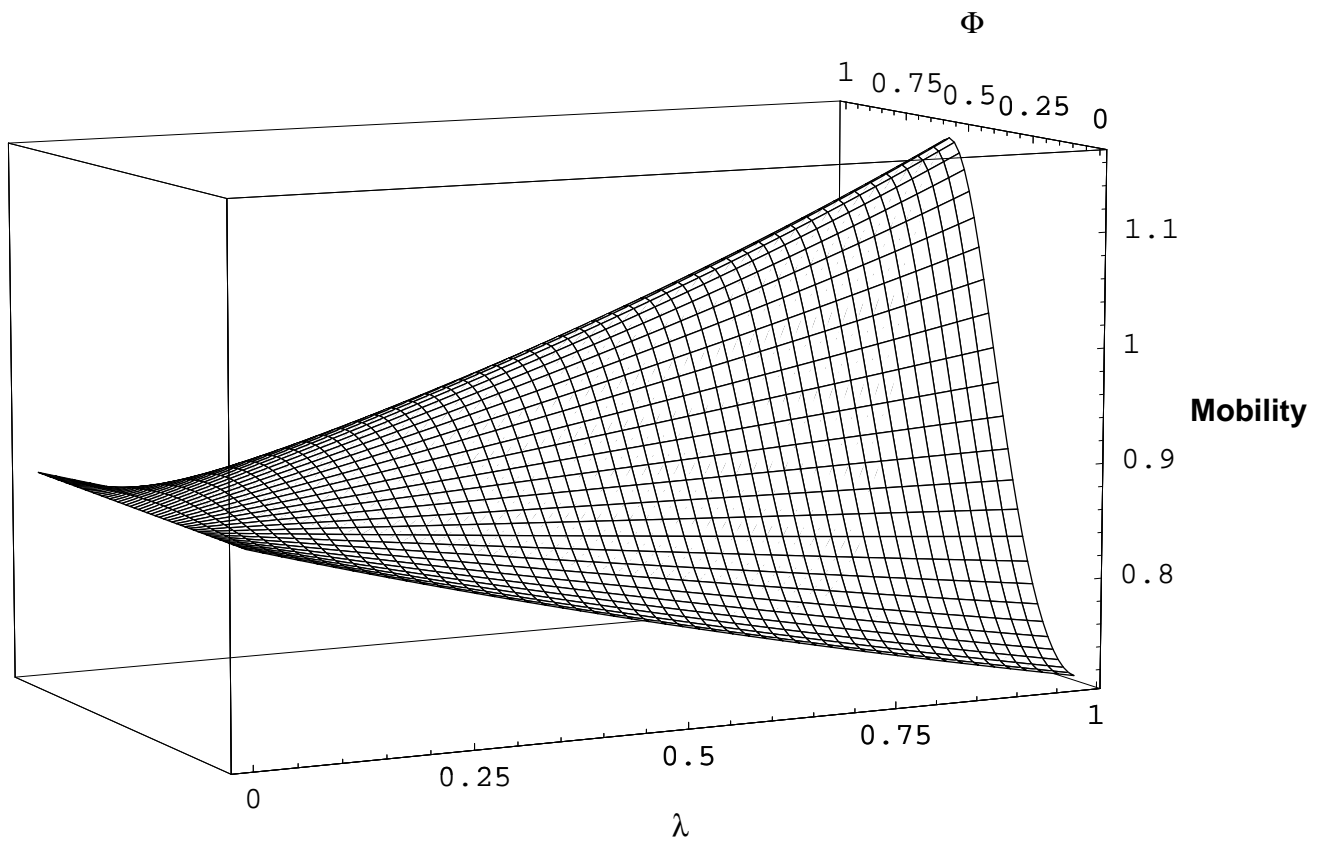

FIG. 6.

FIG. 7.

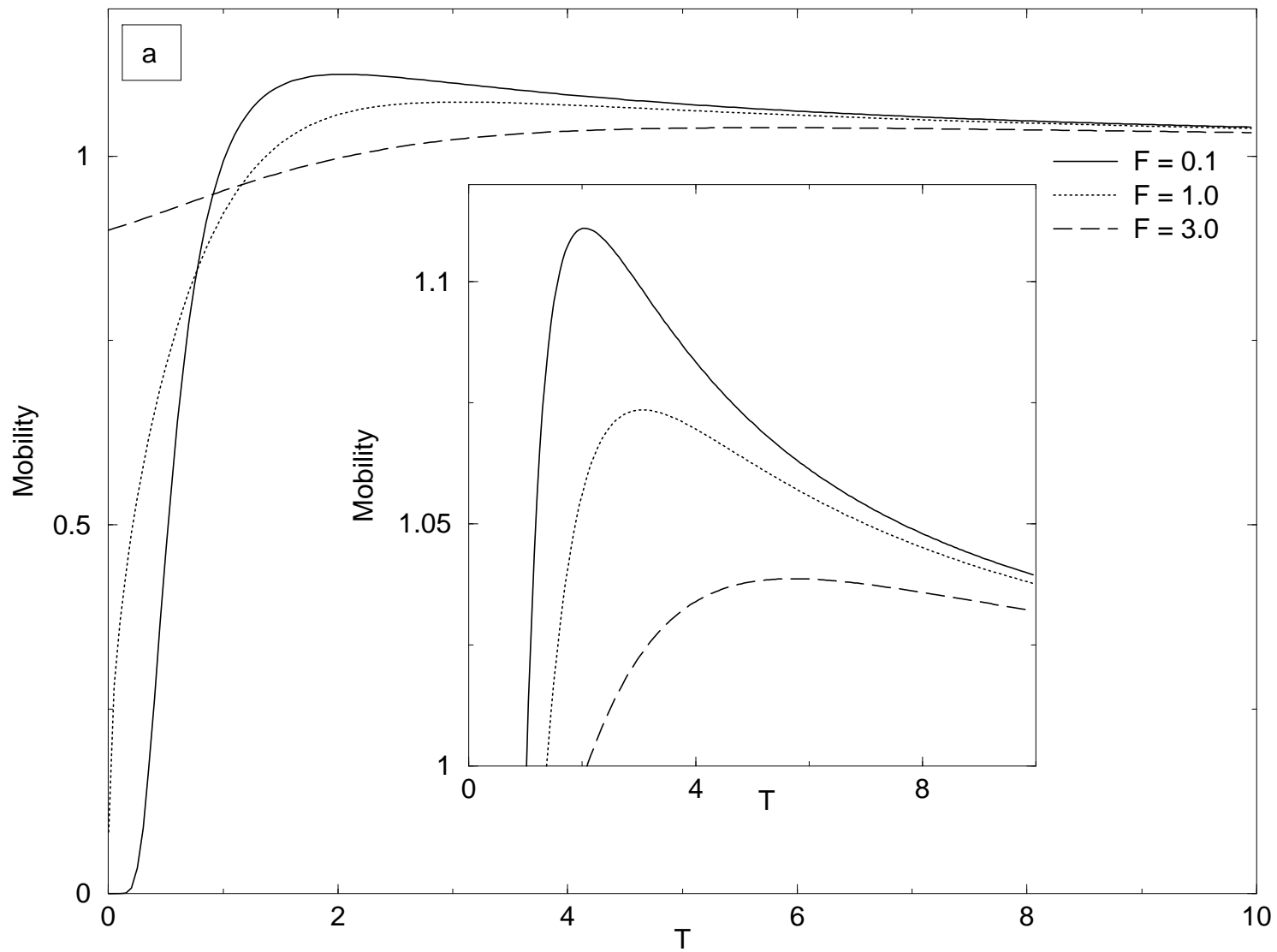

FIG. 7.

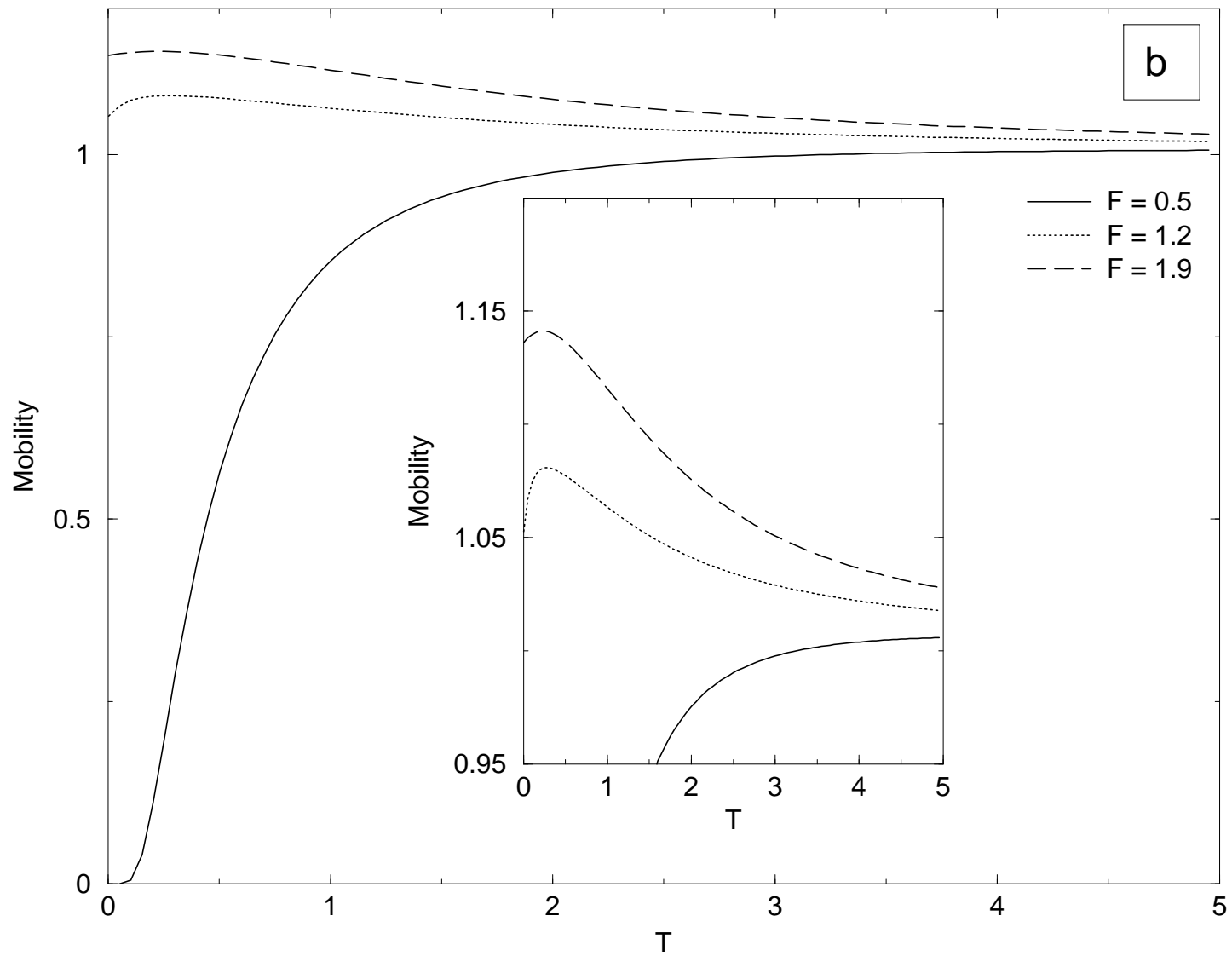
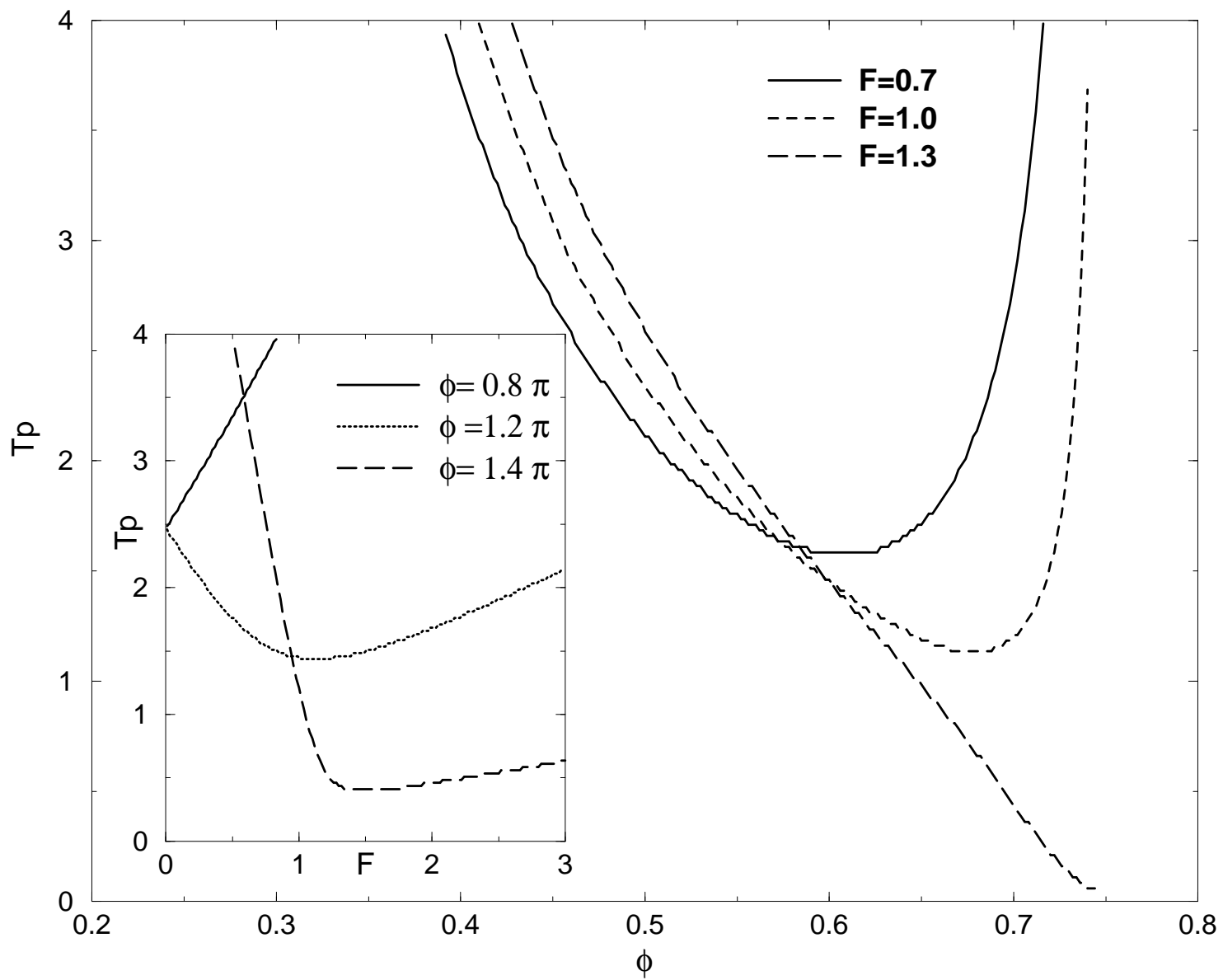

FIG. 8.



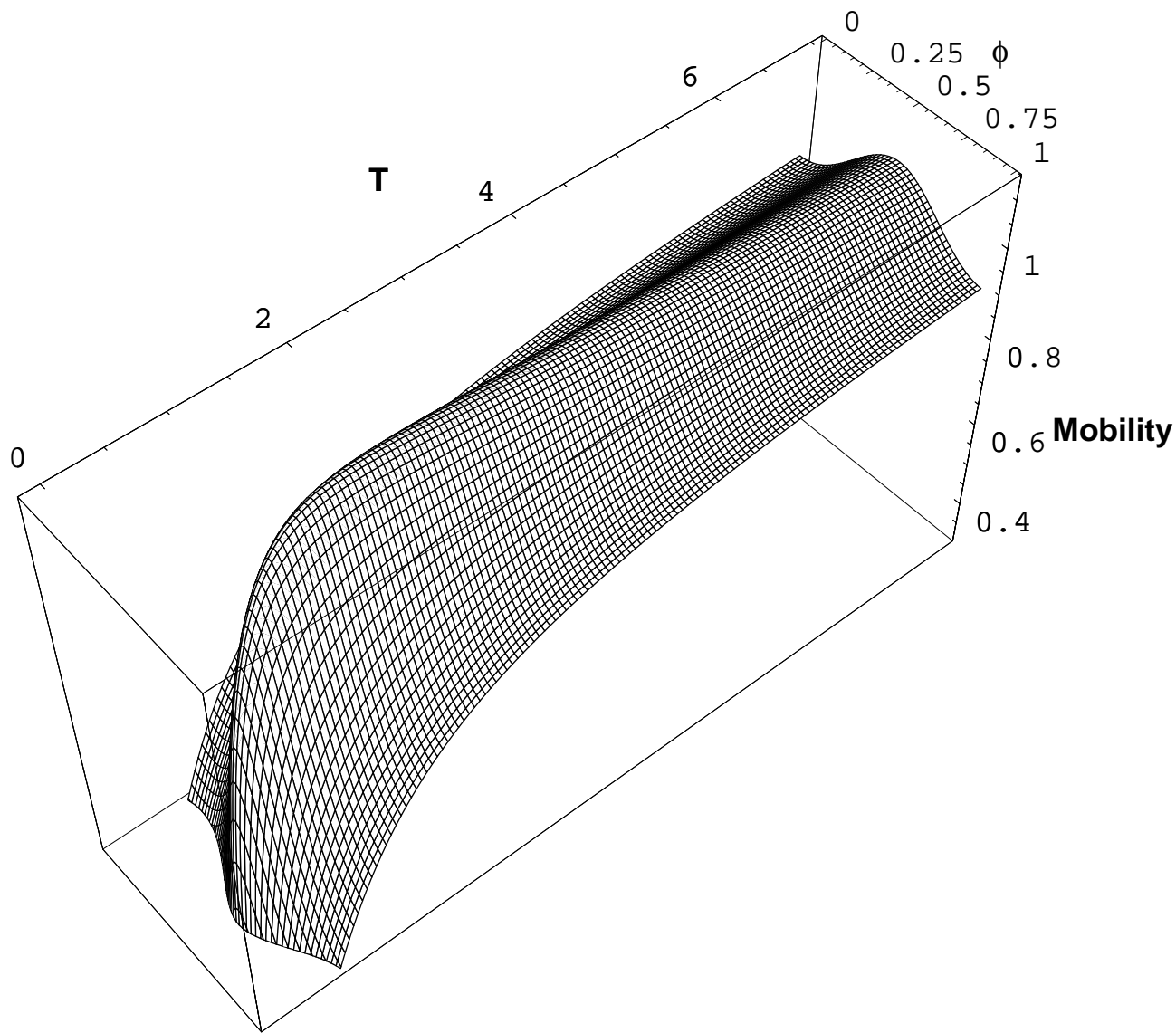

FIG. 9.



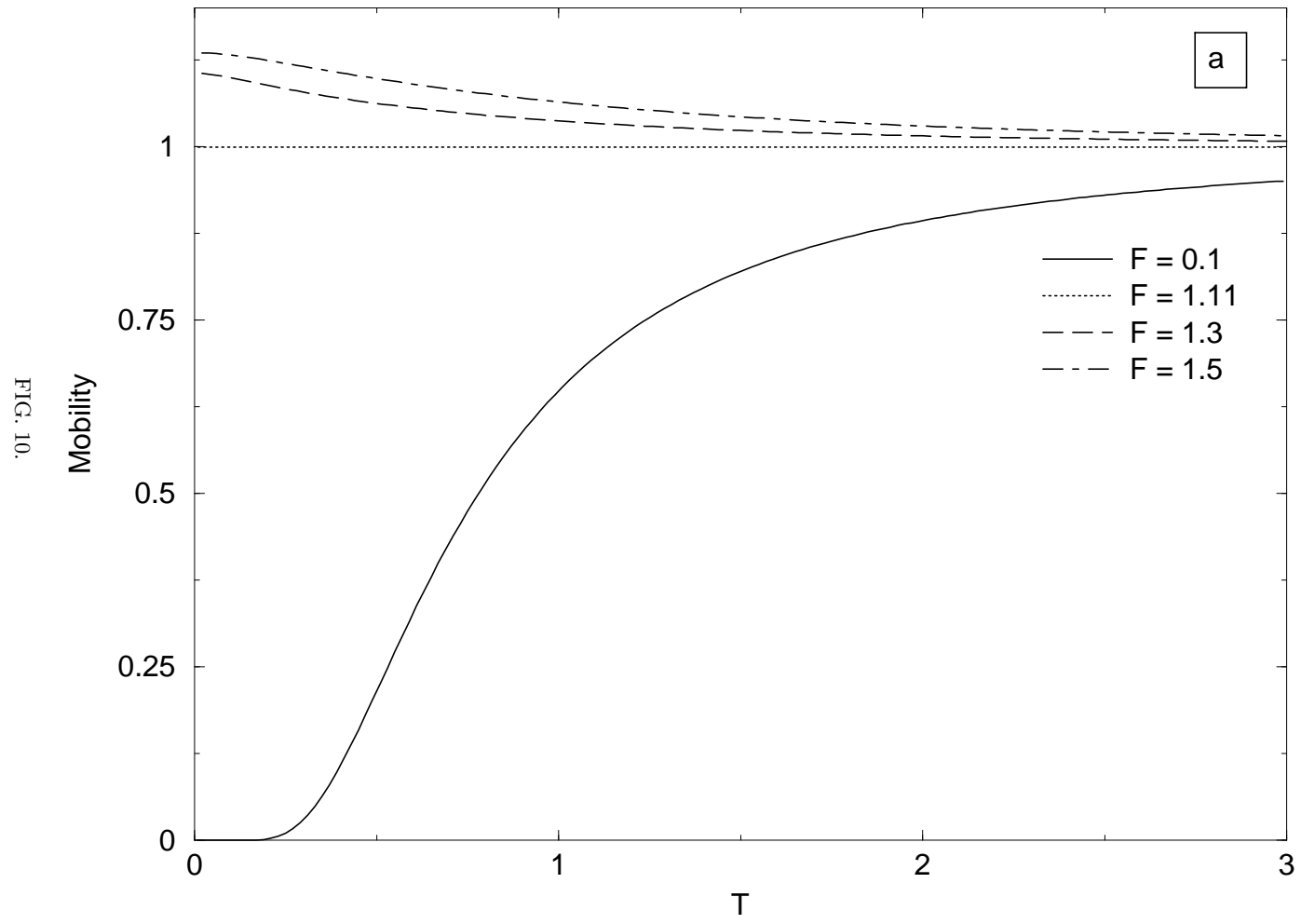

FIG. 9.

