

EXPERIMENTAL STUDIES ON COMBUSTIBLE FUEL BLOCK STRATEGY FOR COOKING

Sharma Monikankana*, H.S Mukunda**, G.Sridhar**

*Tezpur University, Tezpur, Assam

**Combustion Gasification Propulsion Laboratory,

Department of Aerospace Engineering

Indian Institute of Science, Bangalore- 560012

Email: abets@cgpl.iisc.ernet.in

ABSTRACT: This paper presents experimental results of a study on the feasibility of making highly densified fuel block from agro residues that could be used for applications such as domestic cooking and barbecuing. A strategy had been adopted to determine the best suitable raw materials which meet both the criteria of performance and economy. In this regard several experiments were conducted with various raw materials in different proportions and it was found that fuel block composed of 40% biomass, 40% charcoal powder, 15% binder and 5% oxidizer fulfills the requirement of performance as well as economy. The unique geometry of this kind of fuel block (cylindrical one with a number of holes extending from top to bottom unlike traditional biomass briquette with single or no holes) helps in smokeless operation with reasonably steady thermal output. The geometry of the fuel block is so designed that it operates in partially premixed mode of combustion thus leading to better combustion and thereby lower emission. A typical fuel block for cooking weighing about 700-800g provides a thermal output of 1.5 kWth, with a burn time of 1.5 hours. Water boiling tests have indicated a thermal efficiency in the range of 55-58%.

Keywords: cooking, barbecuing, agro-residue.

1.0 INTRODUCTION

Traditional biomass resources are still the primary cooking fuel for the rural people of developing countries, despite the obvious disadvantages in terms of collection effort and indoor air pollution. The main reasons for this heavy dependency upon biomass fuel are unaffordable price of high quality gaseous and liquid fuel and remote locations of the communities. In order to meet the cooking energy demand rural people burn the whole range of biomass such as fuel wood, charcoal, agro residue etc. in traditional cook stoves of varying design. But most of these stoves are inefficient [1] and it leads to increased health hazards. In the last few decades, many technologists have developed improved stoves, which are claimed to be more efficient but the thermal efficiency (percent heat utilization) is reported to be much lower [1-5] compared to fossil fuel

based stoves. This large difference in efficiency between existing improved biomass stoves and high-grade fuel stoves had led to think for a new alternate design, whose performance would be comparable. Besides these, another problem associated with these stoves is their inability to handle leafy or agro wastes. Considering the availability of large amount of leafy or agro waste in rural areas, wherein there is no definite pattern of usage for these fuels, any contrivance that could make use of these fuels would be beneficial in two ways. Firstly, these wastes don't have much opportunity cost (leafy waste in particular) and secondly any well identified usage shall minimize disposal problem. Thus the idea of developing a compact, highly energy densified fuel block from leafy waste got originated. A fuel block can thus be defined as a densified mass, primarily made of agro residues which can

be combusted to extract energy for cooking or heating applications. One other interesting application is barbecuing, which requires slow and steady heating.

2.0 FUEL BLOCK

The approach for designing the fuel block is such that it meets the end-use requirements of cooking in terms of power output and burn duration. Typically, the minimum power requirement to cook food for a meal (for a family of 4) is about 1.5 to 2 kW with burn time about 1.0 to 1.5 hours. Commonly domestic LPG stoves are provided with two burners of 1.5 and 2 kW that work at an efficiency of 40-60 % [4]. Wick type kerosene stoves are also normally of 1.0 and 2.0 kW capacity (with 8-10 and 16 wicks, respectively). Under reasonable wind condition, it operates at an efficiency of 48-58% [4]. Similarly, well-designed wood stove operate at 40-42% efficiency [4] and pulverized fuel stove at 37% [3]. Therefore, there is enough motivation to build a fuel block whose efficiency is closer to LPG. Therefore design for fuel blocks for two applications is addressed in this paper. One is for cooking application, wherein the average thermal output is about 1.5 - 2.0 kWth with a burn time of about 1.5 hours. The other application is for barbecuing, wherein the average thermal output required is about 0.1-0.15 kWth with a burn time of about 40 minutes.

2.1 Working principle

The fuel block works on the principle of gasification. A clue for the design of fuel block has been taken from the findings of the earlier researchers [3, 4, 6, and 7]. A fuel block is cylindrical in shape with an inner port extending from bottom to the top. The fuel block is ignited at the top with a few drops of liquid fuel. Air flow is established because of the free convection from the bottom. As the temperature is raised, pyrolysis starts and volatiles released through the walls of the hole get mixed with air and move upward and then burn at the top of the fuel block. This mode is referred as gasification mode. In the later phase, charcoal (carbon) which is left behind typically 20 to 25 % after the

release of volatiles gets oxidized by oxygen diffusing from the surrounding atmosphere into carbon dioxide. The process of reaction of the gases from pyrolysis with the red hot char lead to products that are similar to normal gasification process [3] (CO , H_2 and CH_4 in addition to from more complex compounds of C-H-O). Thus no fuel can escape without burning. This ensures better combustion and smoke free operation. Whereas, if the same fuel blocks were to operate in combustion mode then the flame would be restricted to the port, the volatiles released (as explained above) would mix with the induced air and burn within the port. This has been observed to perform poorly - incomplete combustion and smoky operation.

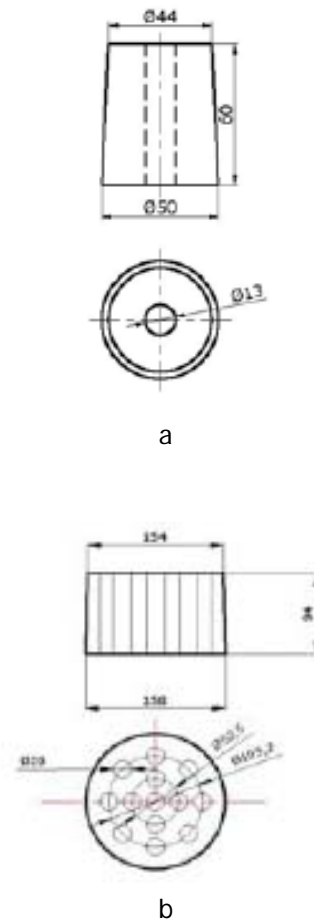

Figure1 (a) Single Port, (b) Multi Port Fuel Block

The design of single and multi hole fuel for barbecuing and cooking respectively is shown in Fig. 1. One design parameter for

the fuel block to operate in gasification mode is the aspect ratio, which is defined as the ratio of height-to-port diameter of the fuel port. In the recent times, Dixit's [3] extensive studies on pulverized fuel stove have indicated that best range of aspect ratio (height-to-port diameter ratio) is about 5 for the stove to operate in gasification mode. This mode of operation ensures a flame on the top of the block, which is essentially premixed flame in nature and ensures complete burning of the fuel. Therefore in the design an aspect ratio between 4.5 and 5.0 was maintained to achieve a fuel block which would work on the principle of gasification as explained above.

2.2 Choice of material

One of the constraint imposed in selection of the raw material was such that the fuel block manufactured should be cost effective and cheaper than some of the conventional fuels meant for cooking. Hence, the attention was focussed on low cost, easily available biomass such as leafy and agro wastes. In this regard the individual physical & thermal properties and also the economy associated with different kind of biomass (even though not exhaustive) were studied and finally a few materials had been identified and the effects of each material were studied thoroughly. The list of selective biomass studied is: saw dust, Coir pith, Bamboo dust, Rice husk powder, leafy dropping like Lucaena Lucocephala, Acacia and Dendrocalamus Strictus. The other raw materials chosen and their anticipated role in the functioning of fuel block are as follows:

Charcoal powder - to increase the energy & packing density

Binder: Clay, Starch, Gum Arabica - to make the fuel block sturdy

Oxidizer: Potassium Nitrate and Sodium Nitrate - to permit faster ignition.

2.3 Design of Fuel Block

The basic shape of the fuel block for barbecuing and cooking is cylindrical and has vertical holes extending from top to

bottom. However, the size of the fuel block differs for cooking and barbecuing. Also, the number of holes has been optimized for both applications. For barbecuing, a single hole fuel block was found to suffice in terms of thermal output, where as for cooking number of holes were varied between 3 and 13 and finally a fuel block with 13 holes was found to provide the required thermal output of 1.5 kWth with a burn time of 80 - 90 minutes. Similarly fuel block with 3 holes was found to operate at 0.33kWth and 6 holes operate at 0.61 kWth. A port diameter of 13 mm and 20 mm were optimized for single and multi hole fuel block. The desirable characteristics of the fuel block are presented in Table I.

Table I: Desirable Characteristics of Fuel Block

Property	Barbecuing	Cooking
Ignition time,	< 2.0 minutes	
Density	As high as possible, to permit slow burning	
Heat rate, kWth	0.13 - 0.15	1.5 to 2.0
Burn time,	~ 40 minutes	80 - 90 minutes
Performance	Smokeless operation with high efficiency	

2.4 Procedure for Preparation

The block diagram for the preparation of fuel block is shown in Fig. 2. The principal steps involved are shredding and pulverizing of biomass in order to homogenize the mixture (homogenization eliminates fast burning), mixing of raw materials with small quantity of water, ramming in a mould to the required shape (with core/s) and finally drying the fuel block to make the fuel block sturdy. The size of shredded biomass and charcoal powder at about 1-2 mm and 0.5 mm respectively was found to be adequate. However, binder and oxidizer had to be fine ground. In this study the fuel blocks were prepared by hand ramming. With mechanization it is possible to productionize the process and make fuel block more cost effective.

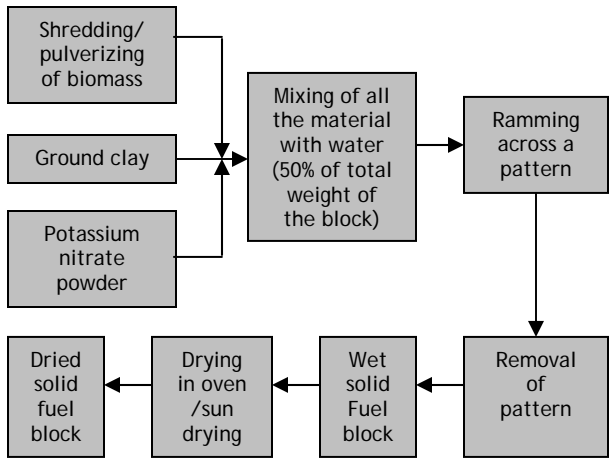

Fig 2: Block diagram of preparation details of fuel block

2.5 Parametric Studies

Nearly 100 trials were conducted with single and multi hole configuration and performance evaluated. These trails include the parametric studies to find the best fuel mixture that would give optimum performance. For the multi hole fuel block water boiling tests were conducted to determine its thermal efficiency. Parametric studies were conducted to find the effect of binder, oxidiser and biomass-to-charcoal on performance.

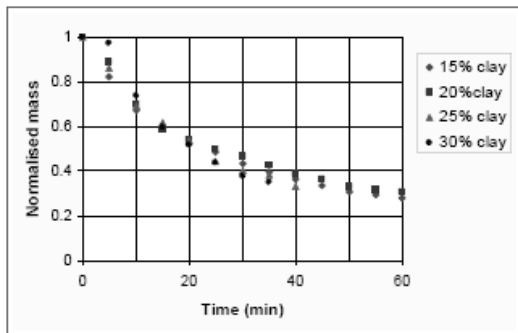

Fig. 3 The effect of clay content on the burn time.

Various types of binders namely, clay, gum arabica (a plant resin) and starch were used as binders. However, experiments revealed that use of clay provides a smokeless performance. Moreover, binders like gum Arabica are expensive (2.5US\$ per kg) and therefore not preferred. The effect of increase in the clay content on the burn time is evident from Fig. 3. Increase in clay

increases the total inert and thereby ash percentage of the fuel block, hence the clay content had to be optimized. A clay content of 20% was found to adequate, whereby the fuel block was found to be strong and met the desired qualities of fuel block as listed in Table 1.

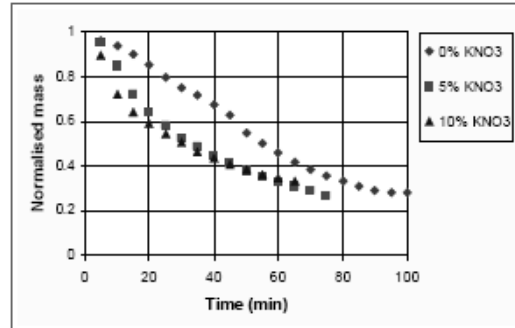

Fig. 4 Effect of Oxidizer on the burn time

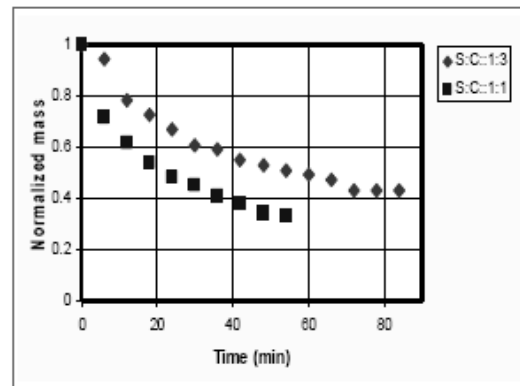

Fig. 5 The effect of charcoal on the burn time. S, C represents sawdust and charcoal respectively

Effect of addition of charcoal powder on the burn time is shown in Fig. 5. Increase in charcoal content was found to increase the packing and energy density of the fuel block. Higher packing density leads to longer burn duration, but at the same time gasification period becomes shorter, as charcoal contains less volatile than biomass. On the other hand if biomass percentage is increased, the fuel block becomes fragile and also the operation becomes smoky (escaping of large amount of volatiles without burning). Hence biomass-to-charcoal ratio needs to be optimized, a ratio of 1:1 was found to be satisfactory. Similarly other biomass like

coir pith, bamboo dust, rice husk powder, leafy droppings etc. also shows similar performance. However, the total ash percentage of the fuel block made of leafy dropping is a bit higher (10-15%)

2.6 Observations

Based on parametric studies a fuel block of following composition was found to meet the requirement of power level and burn time. The optimum composition is as follows:

Biomass: 40%, charcoal: 40%, clay: 15%, KNO₃: 5%.

The thermo-physical parameters of the optimum fuel block are summarized in Table 2.

Table 2 Optimum Parameters of Fuel Block

Parameter	Single hole	Multi hole
LCV, MJ/kg	18-19	
Ash, %	28 -30	
Density, kg/m ³	550 - 600	
Size, mm	47 dia x 60 height	156 dia x 94
Hole, mm	13 dia	20 dia
Holes	1	13
Weight, g	50 - 60	700 - 800
Mean thermal	0.13 - 0.15	1.5 - 2.0
Burn time, minutes	35 - 40	80 - 90

Water boiling tests with the multi hole fuel block has yielded a thermal efficiency of 55 - 58% at a mean thermal power output of 1.5 to 2.0 kWth

2.7 Economy

Table 3 shows the comparison of energy cost of different fuels. Here the calculation is shown based on efficiency, input power requirement and burn duration required for cooking a meal. This is based on the following hypothesis, which is close to reality. Typical cooking requirement for a family of 4/5 is about 1.5 kW for duration of about 1 hour amounting to 5.4 MJ. Under these considerations the fuel block is cost-effective compared to conventional fuels.

Table 3: Efficiency and cost of different fuels for stove output energy of 5.4 MJ

Fuel	Efficiency , %	Stove input energy (MJ)	Cost per MJ (US Cent)	Energy Cost (US Cent)
LPG	60#	9	0.9	8.2
Kerosene	55#	9.8	1.5	14.5
Fire wood	30#	18	0.4	7.0
Fuel block	58*	8.7	0.5	4.0

3.0 CONCLUSIONS

This study has demonstrated the following:

1. Using agro or leafy waste material, a highly densified fuel block can be manufactured
2. It can find application ranging from barbecuing to cooking
3. By varying the number of holes and overall size of the fuel block, it can be made to operate at different power level
4. Its performance is superior to traditional biomass stove and comparable to high grade fuels like LPG/ kerosene.
5. In this study the fuel blocks were prepared by hand ramming. With mechanization it is possible to productionize the process and make fuel block more cost effective.

4.0 REFERENCES

1. Bhattacharya, S.C, D.O. Albina and Aung Myint Khaing, "Effects of selected parameters on performance and emission of biomass fired cook stoves", *Biomass and Bioenergy*, 23, Issue 5, pp 387-395, Nov. 2002.
2. Ballard.G and H.H. Jawurek, "Comparison of five rural, wood burning cooking devices: efficiencies and emissions", *Biomass and Bio energy*, Vol.11, No5, pp 419-430, 1996.
3. Bhaskar Dixit C. S. "Experimental and computational studies on pulverized fuel stoves", Ph.D. Thesis, Combustion Gasification Propulsion Laboratory, IISc, 2003.
4. Mukunda, H.S., U.Shrinivasa and S. Dasappa, "Portable single pan wood stove for high efficiency", *Sadhana*, 13, pp 237-270, 1988.
5. Reed, T.B., E. Anselmo, and K.Kircher, "Testing and modeling the wood gas turbo stove", in *The International Conference on Biomass-based Fuels and Cooking Systems*, edited by K.Priyadarshini, Appropriate Rural Technology Institute (ARTI), 2000.
6. Mukunda H.S., S.Dasappa, P.J.Paul, N.K.S.Rajan, and U.Shrinivasa, *Gasifiers and combustor for biomass-technology and field studies*, *Energy for Sustainable Development*,1,27-38,1994
7. Mukunda, H.S., S. Dasappa, B.Swati and U.Shrinivasa, "Studies on stove for powdery biomass, *International journal of energy research*", 17, pp 281-291, 1993.