

THE INFRA-RED ABSORPTION BY DIAMOND AND ITS SIGNIFICANCE

Part VI. The Free Vibrations of the Structure

BY SIR C. V. RAMAN

(*Memoir No. 129 of the Raman Research Institute, Bangalore-6*)

Received December 12, 1961

1. INTRODUCTION

BEFORE we can usefully take up the discussion of the infra-red activity exhibited by diamond, we have, in the first place, to consider the dynamical behaviour of the structure of the crystal and determine the characteristic modes and frequencies of free vibration of the atomic nuclei which constitute that structure about their positions of equilibrium. The simplicity of the structure and the fact that the atomic nuclei in the crystal all have the same mass makes it possible to deal with this problem and find its solution by an elegant procedure. The basis of the treatment is the theorem in classical mechanics which states that all the possible small vibrations of a connected system of particles are a superposition of a set of normal modes in each of which all the particles oscillate with the same frequency and in the same or opposite phases, the number of the normal modes being the same as the number of dynamical degrees of freedom of movement of the particles in the system. The atomic nuclei being enormously more massive than the electrons, we are justified in considering them as simple mass-particles with the movements of which we are concerned, while the electrons in the crystal are regarded as springs which hold the nuclei in position, the strength of the springs determining the possible frequencies of vibration of the nuclei.

2. THE STRUCTURE OF DIAMOND

Diamond exhibits in its structure the most perfect demonstration of the validity of the concept of the tetrahedral carbon atom. Each carbon nucleus is held to four other nuclei grouped around it in an exactly tetrahedral configuration, these four other nuclei again being connected to others grouped around them in the same fashion. The structure thus built up is continued in all directions throughout the volume of the crystal. How and why this tetrahedral configuration is set up and maintained with the perfection actually observed are questions which we shall not here enter into. They will be taken up for consideration later in our discussion of the infra-red

activity of the crystal. What we are here concerned with is the ordering of the atomic nuclei within the volume of the crystal.

The structure of diamond may be described compendiously as composed of two interpenetrating face-centred cubic lattices. For our present purpose, it is more usefully regarded as composed of two interpenetrating rhombohedral lattices, eight nuclei situated at the points of each of which delineate the unit rhombohedral cell. Thus, two sets of eight nuclei, in other words, 16 nuclei taken together form the unit with the dynamical behaviour of which we are concerned in our studies. The nuclei appear in the crystal in equidistant layers parallel to its cubic planes, while in the octahedral layers the nuclei appear in layers which are alternately nearer together and further apart in the ratio of one to three.

3. THE NORMAL MODES OF VIBRATION

A crystal is an extended system which is a three-dimensionally periodic array in space of structural units, each of which contains a finite number, which we shall denote by p , of non-equivalent mass-particles. The interaction of the structural units with each other has, of necessity, to be considered in considering the possible modes of vibration of these structural units. By writing down the equations of motion of the p non-equivalent particles in any one structural unit and proceeding to solve them to find their normal modes of vibration, it is readily established that there are really eight species of normal modes, all of which are comprised in the following statement: *in any one normal mode, equivalent atoms in the successive cells of the structure situated along its axes have the same amplitude of vibration and a phase which is either the same or else alternates in successive cells of the structure along one, two or all three axes of the lattice.* The alternatives for the three axes of the lattice being independent, we have $2 \times 2 \times 2$ or 8 distinct possibilities, in other words, 8 distinct species of normal modes. The same result may also be very simply derived from the consideration that the structure of the crystal is brought into coincidence with itself by a unit translation along any one axis, and hence a normal mode of vibration which is a property of the structure must also conform to the principle of translational symmetry. This is possible only if, following a unit translation, the amplitudes of vibration of equivalent atoms remain unaltered and the phases all remain unaltered or else are all reversed. This way of regarding the matter is instructive since it indicates that what we have referred to as the normal modes of vibration of the structural units may equally well be described as the stationary modes of vibration of the extended system of particles forming a periodic structure which constitutes the crystal.

The 8 sets of $3p$ equations each for the normal modes when solved give us $24p$ solutions, of which only $(24p - 3)$ represent actual vibrational modes, the 3 excluded solutions representing the translations of the group of $8p$ atoms which in effect is the dynamic unit of which the degrees of freedom appear as normal modes. In the case of diamond, $p = 2$; hence we have 45 normal modes of vibration. By reason, however, of the cubic symmetry of the structure, all of these modes are degenerate. A further simplification arises by reason of the fact that the two non-equivalent atoms have the same mass. It turns out that there are only eight distinct and discrete frequencies of free vibration of the structure of diamond corresponding to the modes described and listed below in Table I.

TABLE I

| Mode | Description | Degeneracy | Frequency cm. ⁻¹ |
|--------|---|------------|--------------------------------|
| I | Oscillation of the two lattices in opposite phases | 3 | 1332 |
| II | Tangential oscillation of the octahedral planes in opposite phases | 8 | 1273 |
| III | Tangential oscillation of the cubic planes in opposite phases | 6 | 1219 |
| IV | Normal oscillation of the octahedral planes in opposite phases | 4 | 1176 |
| V & VI | Normal oscillation of the cubic planes in the same or opposite phases | 3 + 3 | 1087 |
| VII | Normal oscillations of the octahedral planes in the same phase | 4 | 1010 |
| VIII | Tangential oscillation of the cubic planes in the same phase | 6 | 746 |
| IX | Tangential oscillation of the octahedral planes in the same phase | 8 | 624 |
| | Translations | 3 | 624 → 0 |
| | Total .. | 48 | |

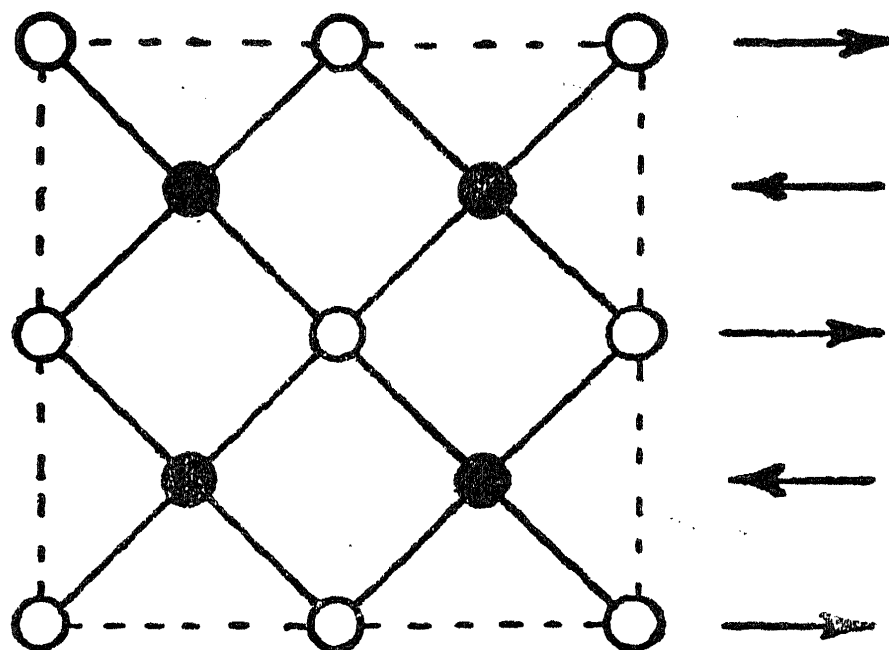

FIG. 1. The triply degenerate mode of highest frequency.

4. DESCRIPTION OF THE NORMAL MODES

The geometric characters of the free vibrations of the structure described and listed in Table I may be deduced in the following manner. Considering a simple rhombohedral lattice, the eight possible situations regarding the phase of the movements at its lattice points give us firstly, a simple translation of the whole lattice, four movements in which the nuclei in the alternate octahedral planes move in opposite phases and three others which are movements of the cubic planes alternately in opposite phases. There are two rhombohedral lattices to be considered and their phases may be either the same or opposed to each other. The directions in which the movements occur are determined by the symmetry of the structure. They would evidently be either normal or tangential to the layers concerned, the tangential movements being twice as numerous as the normal ones. The translations of the two lattices if in opposite phases yield a triply degenerate mode of vibration, and if in the same phase only a simple translation. Thus, in all, we have nine species of normal modes, as shown in Table I with their respective degeneracies, but only eight distinct frequencies since the fifth and sixth modes are indistinguishable.

Figure 1 depicts the triply degenerate mode listed in Table I as that of highest frequency. In Fig. 2, the four octahedral modes are depicted and in Fig. 3, the four cubic modes. In these diagrams, the valence bonds linking the carbon atoms with each other have been shown with a view to indicate the extent to which the movement depicted involves an extension of the valence bonds or changes in the valence-angles. We are thereby enabled to perceive at a glance whether the frequencies of the modes would be high or low and also to compare the different modes with each other.

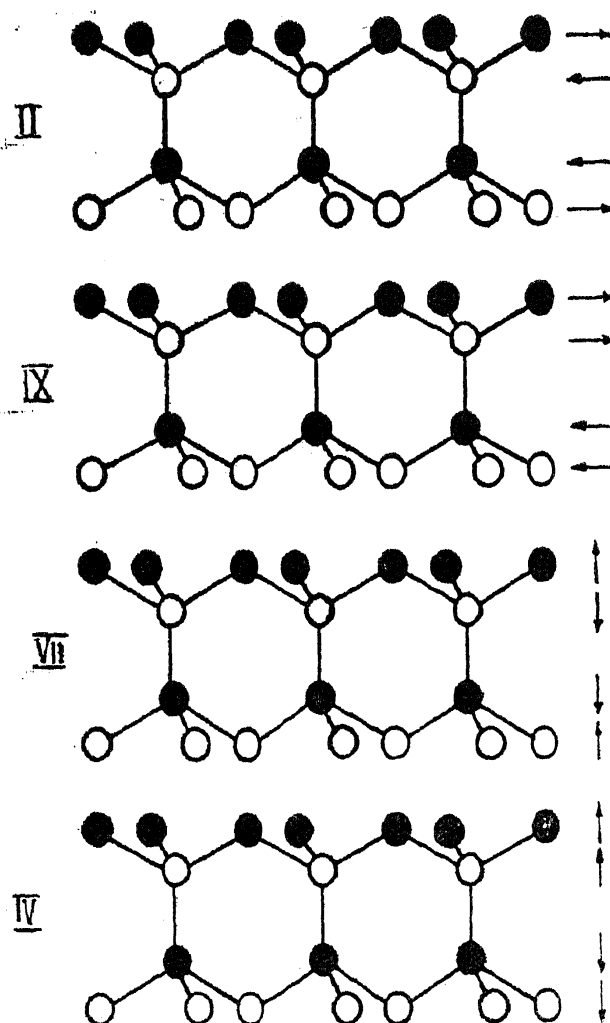

FIG. 2. The four octahedral modes of oscillation.

The mode depicted in Fig. 1 evidently involves a periodic stretching or compression of all the four bonds which connect a carbon with its four immediate neighbours, as also variations of all the bond angles. It follows that this would be the mode of highest frequency. The tangential oscillation in which the adjacent octahedral planes move in opposite phases (marked II in Fig. 2) involves changes in three bond-lengths and would therefore have a high frequency. It appears as mode II in the Table. *Per contra* the mode in which the octahedral planes move in the same phase (marked IX in Fig. 2) does not involve a change in length of any of the four bonds and hence it should have the lowest frequency of all the modes. It is accordingly listed as IX in the Table. The cubic mode marked as VIII in Fig. 3 also involves no changes in bond-lengths and would therefore be of low frequency. It appears as the last entry but one in Table I. The cubic mode marked III in Fig. 3 involves changes in only two bond-lengths out of the four and accordingly takes its place as the third listed in Table I. Modes IV, V, VI and VII take intermediate positions in the list which can only be determined by con-

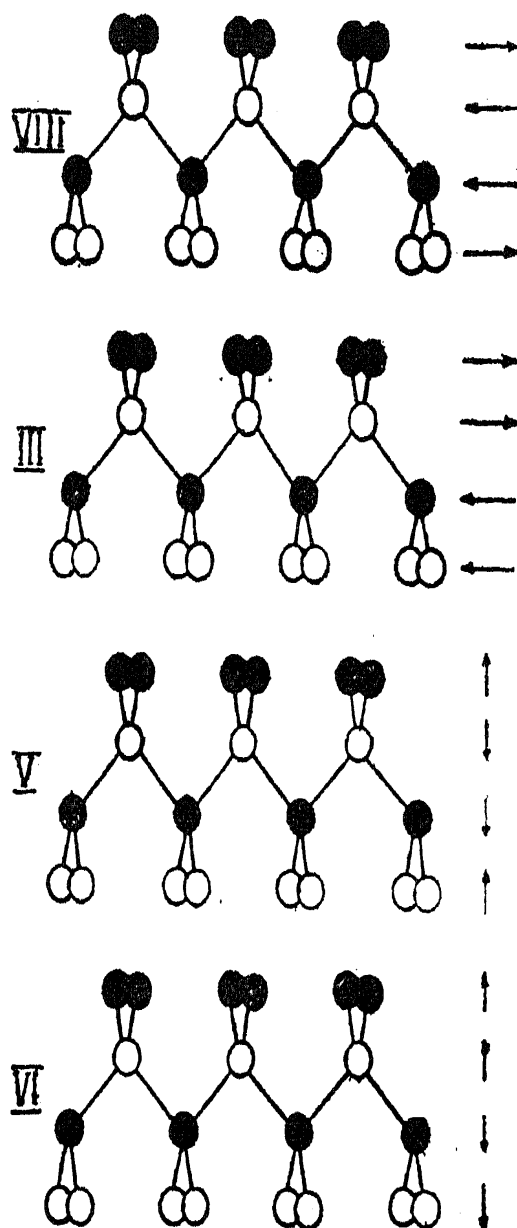

FIG. 3. The four cubic modes of oscillation.

siderations of a quantitative character. These will be set forth in a later part of the memoir.

5. SUMMARY

It is shown that the structure of diamond has eight discrete frequencies of free vibration. The mode of highest frequency is an oscillation of the two interpenetrating lattices of carbon nuclei with respect to each other. The other frequencies represent the oscillations of the octahedral or cubic layers in the crystal either normally or tangentially to themselves.