

# DECAY-TIME OF SCINTILLATIONS IN CsI (Tl) CRYSTAL

BY N. P. SASTRY AND B. V. THOSAR, F.A.Sc.

(Tata Institute of Fundamental Research, Bombay-5, India)

Received August 1, 1961

## INTRODUCTION

It is known that crystals of alkali halides activated with thallium are efficient scintillators. Because of their simplicity of crystalline structure, confinement of luminescence emission to thallium centres, and the possibility of using photomultiplier tubes to study the characteristics of their light emission, a detailed study of these crystals when excited by nuclear radiations is desirable.

It was reported earlier (Lagu and Thosar, 1961) that a single crystal of CsI (Tl) emits two prominent bands in the visible region when excited by  $\gamma$ -rays or ultra-violet. One is a band in the blue, and the other is a doublet band in the yellow. The emission spectra, both under  $\gamma$ -rays and ultra-violet excitations, show maxima centred around the same wavelengths, indicating that the luminescent centre responsible for emission in the two cases is the same. Assuming that thallium ion is the centre of luminescence, these emission bands are the result of de-excitation of the excited levels of this localised centre. In such a case, it is possible to have different transition probabilities for the processes giving the two emission bands. Measurement of the decay times of luminescence in these individual bands is necessary to obtain information about the transition probabilities.

## EXPERIMENTAL PROCEDURE

A study of decay times of scintillations of CsI (Tl) was made under excitation by  $\gamma$ -rays of energy 1.3 Mev. from a  $\text{Co}^{60}$  source and under  $\alpha$ -particles from a Polonium source (S in Fig. 1). Suitable filters F were interposed between the crystal C and the photomultiplier to isolate the two emission regions, blue and yellow. The transmission characteristics of the filters in relation to the emission bands are shown in Fig. 2.

The method of measurement of decay time consists in investigating the shape of the voltage pulse at the anode of a photomultiplier tube (6810 A) which views the scintillation light pulses from the crystal CsI (Tl) (Fig. 1).

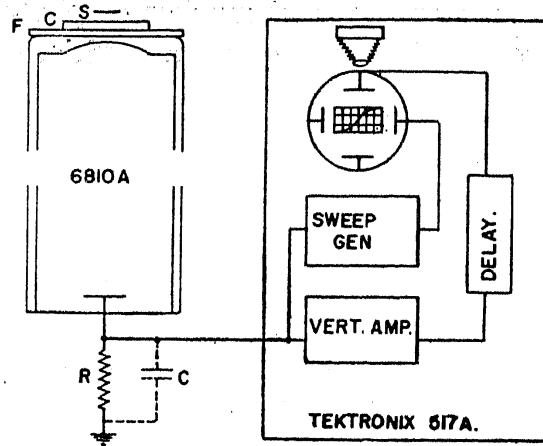

FIG. 1. Schematic diagram of experimental arrangement.

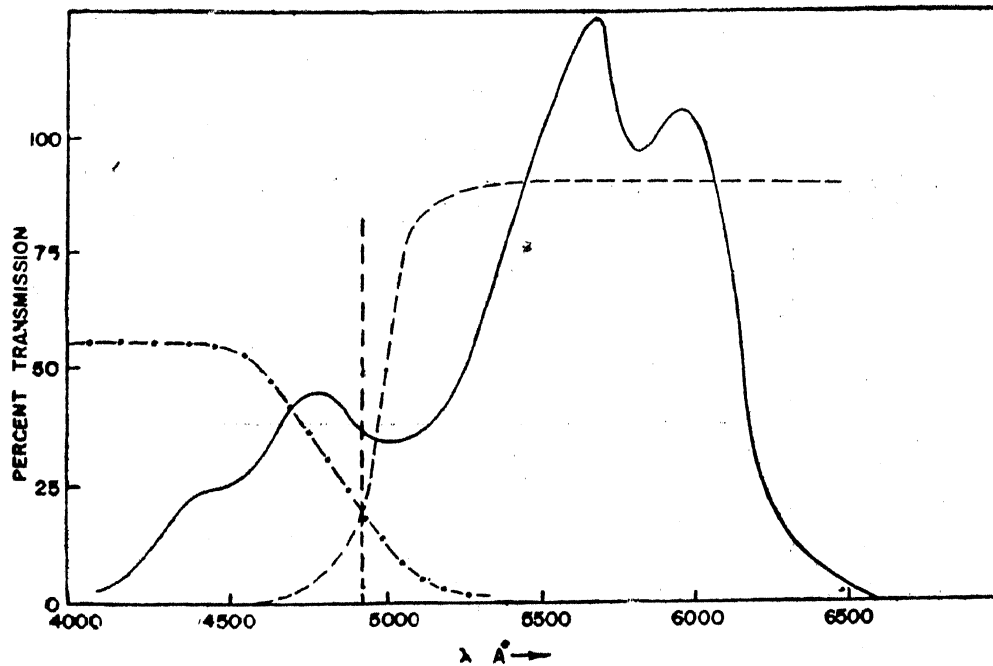

FIG. 2. Solid curve is the emission spectrum of CsI (Tl). The transmission, in arbitrary units, for the blue (---) and yellow (-.-.-) filters is also shown.

If the light pulse follows an exponential decay the height of the voltage pulse  $V$  at any instant of time  $t$  from the start of the pulse is given by

$$V(t) = \frac{V_0}{\tau - RC} \{e^{-t/\tau} - e^{-t/RC}\}$$

where  $\tau$  is the decay time of the light pulse,  $RC$  is the effective time constant of the anode load of the photomultiplier tube and  $V_0$  is the maximum height

of the pulse.  $V_0$  depends on the total number of photons emitted by the crystal due to absorption of a  $\gamma$ -ray or an  $\alpha$ -particle.

(i) When RC is made much larger compared to  $\tau$ , the shape of the voltage pulse is an inverted exponential whose rise time corresponds to the decay time of the light pulse. If there are two components of decay, the shorter component would be integrated first. If the long component is about ten times larger than the short component, the rise part of the voltage pulse corresponds to the short component decay time. In the present experiment the short component of decay was measured by a method of adjusted magnification, which is explained below.

A standard exponential is drawn on a sheet of graph paper. The photographic negative of the oscilloscope trace of the pulse is put in an enlarger. The magnification of the projected image is adjusted such that with the base line of the drawn exponential coincident with the line at maximum height of the pulse the image of the pulse and the standard curve coincide with each other (Fig. 3). When this happens, it is obvious that  $V_0 e^{-x} = V_0 e^{-t/\tau}$ . Then,  $x \cdot \tau = t$ , or  $\tau = t$  for  $x = 1$ . So, the time  $t$  on

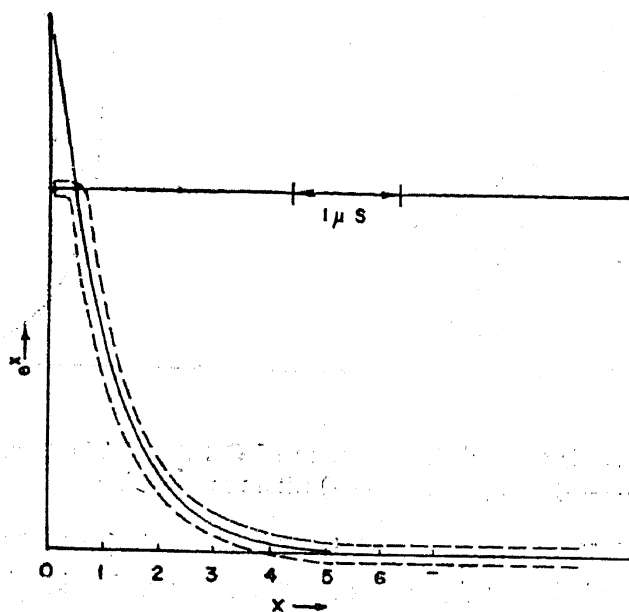

FIG. 3. Method of adjusted magnification.  $x = 1$  on standard exponential (solid curve) corresponds to  $0.5 \mu$  sec. on the scale of the projected pulse image (dotted curves) when fitted. The pulse, with base line at the top, is due to alpha-rays, with yellow filter and  $RC = 10 \mu$  sec.

the trace image, corresponding to  $x = 1$  on the graph sheet, equals the decay time  $\tau$ . In this way, analysis becomes easy, and the results are comparable

in accuracy to the method of least squares, since every part of interest on the pulse image is used for comparison with the standard exponential.

(ii) In the non-integrating method, RC is made much smaller than  $\tau$  and then the decay of the voltage pulse corresponds to the decay of the light pulse. However, because the smoothing action of the integrated pulse method is now negligible, the pulse looks jagged. This effect is more pronounced if the number of photoelectrons ejected by the photocathode becomes small, as was the case when filters had to be used between crystal and photomultiplier. If RC is of the order of  $\tau/n$  where  $n$  is the total number of photoelectrons from cathode per pulse, then pulses due to single electrons leaving cathode can be seen. These will be called elementary pulses hereafter. The elementary pulses can be counted provided there is no optical integration due to finite width of the oscilloscope beam trace. The amount of optical overlap depends on the sweep speed. At high speeds, the time interval corresponding to the size of the spot is small and the individual pulses are well separated. But only a small portion of the entire pulse is seen since the time for the visible length of the trace is small at higher sweep speeds. In a compromise situation, there will be some optical integration at the beginning of the pulses, but counting of individual elementary pulses over a reasonable length of the pulse can be made. A least squares fit to the numbers of photoelectrons from cathode counted in this manner, for successive equal time intervals, gives a value of the long component of the decay time. This method had to be used in the present experiment, where very low light level measurements were encountered. When only a few photons are emitted per pulse, the term decay time loses its significance.

At the limit of low light level measurements of decay times, there is a problem worth mentioning. When RC becomes so small that electronic integration is absent even for the first few photoelectrons, then the trace-initiating trigger level for the oscilloscope has to be small enough, to be operated by the first photoelectron. In this case, even thermal electrons released from the photocathode can trigger the scope trace. To reduce the number of such unwanted trace triggers, which cause an unwelcome fogging of the negative, the photocathode may have to be cooled. Besides, the method obviously fails when the number of elementary pulses counted per the chosen time interval becomes comparable to the number of thermal electrons from the cathode.

The short component of decay was investigated by the first method of adjusted magnification described above, with RC = 10  $\mu$ s. The long

components of decay were measured by the second method, with an estimated  $RC = 10 \text{ ns}$ .

### RESULTS AND DISCUSSION

The results obtained for the decay time for the short and long components of decay in CsI(Tl) by the two methods described above, are summarised in Table I. This gives the values of  $\tau_1$  and  $\tau_2$  for the two

TABLE I

Excitant	$\tau_1$ in $\mu$ sec.		$\tau_2$ in $\mu$ sec.	
	Blue	Yellow	Blue	Yellow
Po- $\alpha$ ..	$0.51 \pm 0.02$	$0.49 \pm 0.02$	$12.1 \pm 2.0$	$9.5 \pm 2.0$
Co- $\gamma$ ..	$0.89 \pm 0.06$	$0.99 \pm 0.06$	$7.6 \pm 2.0$	$9.8 \pm 2.0$

emission bands, blue and yellow excited with Polonium  $\alpha$ -rays and Cobalt-60  $\gamma$ -rays. About 15 to 20 pulse traces of each kind were examined to arrive at the average values. The limits of probable error are indicated. It may be seen that within the limits of experimental error there is no change in the decay time for the two emission bands, blue and yellow. This is true for both short- and long-lived decay components and whatever the exciting radiation. In the case of short-lived decay component  $\tau_1$ , in both the blue and yellow bands, the decay time is significantly smaller for  $\alpha$ -ray excitation than for  $\gamma$ -rays. In the case of the long-lived component of decay, the variation in decay time, if any, with the nature of exciting radiation, is within the limits of experimental error and is not significant.

There is a marked decrease in the decay time of the short-lived component when the crystal is excited by  $\alpha$ -particles instead of by  $\gamma$ -rays. A similar trend was observed by Storey, Jack and Ward (1958) who studied the decay time for a thin crystal of CsI(Tl), using  $\alpha$ -particles, protons and electrons as excitant. The decrease in  $\tau$  with increasing ionization density reported by them is in agreement with the above results. A change in decay time of scintillations with the nature of exciting radiation for NaI(Tl) crystal was reported earlier (Thosar and others, 1959).

### SUMMARY

Decay times of scintillations excited in a CsI(Tl) crystal by  $\alpha$ -particles and  $\gamma$ -rays have been studied for the two regions of the emission spectrum,

blue and yellow. Voltage pulses from a photo-multiplier tube, viewing the crystal, as seen on a high-speed oscilloscope have been photographed and investigated. There are two decay components, short- and long-lived. In the case of the long-lived component ( $\tau = 10 \mu \text{ sec.}$ ) there is no significant variation in decay time with the nature of excitant or the type of emission band. In the case of the short-lived component there is no variation with the type of emission band but there is a marked decrease in the decay time for  $\alpha$ -particle excitation ( $\tau = 0.5 \mu \text{ sec.}$ ) compared to that for  $\gamma$ -rays ( $\tau = 0.9 \mu \text{ sec.}$ ).

## REFERENCES

1. Lagu, R. G. and Thosar, B. V. *Proc. Ind. Acad. Sci.*, 1961, **53 A**, 219.
2. Storey, Jack and Ward *Proc. Phys. Soc.*, 1958, **72**, 1.
3. Thosar, B. V., Sastry, N. P. and Lagu, R. G. *Proceedings of Symposium on Spectroscopy, Delhi*, 1959, p. 23.