

Dynamic algorithm for parameter estimation and its applications

Anil Maybhate^{1,2,*} and R.E.Amritkar^{1,†}

¹*Physical Research Laboratory, Navrangpura, Ahmedabad 380009, India*

²*Department of Physics, University of Pune, Pune 411007 India*

We consider a dynamic method, based on synchronization and adaptive control, to estimate unknown parameters of a nonlinear dynamical system from a given scalar chaotic time series. We present an important extension of the method when time series of a scalar function of the variables of the underlying dynamical system is given. We find that it is possible to obtain synchronization as well as parameter estimation using such a time series. We then consider a general quadratic flow in three dimensions and discuss applicability of our method of parameter estimation in this case. In practical situations one expects only a finite time series of a system variable to be known. We show that the finite time series can be repeatedly used to estimate unknown parameters with an accuracy which improves and then saturates to a constant value with repeated use of the time series. Finally we suggest an important application of the parameter estimation method. We propose that the method can be used to confirm the correctness of a trial function modeling an external unknown perturbation to a known system. We show that our method produces exact synchronization with the given time series only when the trial function has a form identical to that of the perturbation.

PACS number(s): 05.45.-a, 05.45.Tp, 05.45.Xt

I. INTRODUCTION

An experimental observation often consists of reading a time series output from a dynamical system. Such a time series can contain information about the number as well as the form of the functions governing the evolution of the system variables including nonlinearities (if any) and the parameters [1]. The estimation of parameter values from a given chaotic scalar time series of a nonlinear system is the topic of our interest here.

We have recently given a method to dynamically estimate unknown parameters from the chaotic time series of a single phase space variable when the system equations are known [2]. The method is based on a combination of synchronization [3–5] and adaptive control [6] similar to that used by John and Amritkar [7,8].

The problem of parameter estimation in nonlinear dynamics has been considered earlier. Parlitz, Junge and Kocarev have given a static method [9] based on minimization while Parlitz has developed a method based on auto-synchronization [10]. Unlike our method, auto-synchronization method requires an ansatz for the parameter control loop and gives slower convergences in many cases. A method requiring a vector time series is given by Baker, Gollub and Blackburn [11] and another method based on symbolic dynamics is discussed in Refs. [12–14]. The effect of noise on parameter estimation was studied by us [2] and recently by Goodwin, Brown and Junge [15]. In contrast to many of these methods our method in Ref. [2] works asymptotically so that an exact estimation of the parameters is in principle possible.

The static methods based on minimization are computationally expensive because they take a longer time to run due to many iterations required for convergence and they also require annealing to eliminate the possibility of getting trapped into a local minimum. The dynamic method as described in Ref. [2] requires only one time evolution of the system equations. The method also takes care of annealing in a dynamic way.

In the first part of this paper we review our method for parameter estimation in brief. We then extend it to a case when the time series of a *scalar function* of phase space variables is given. We then go on to study the applicability of the method to a general quadratic flow in three dimensions. This system has a large number of parameters and we try to estimate some of them using our method.

In the second part, we show that it is possible to extend our method to a more realistic situation, when the given time series is truncated after a finite time. We find that a repetitive use of the finite time series can be made to estimate the unknown parameters of the underlying system without altering the dynamic nature of the method. The accuracy of such an estimation increases with the increasing length of the given time series. We also see that the accuracy saturates with the number of times the finite time series is used.

Lastly in the third part of this paper, we suggest an interesting application of parameter estimation method. Consider a situation where an unknown perturbation disturbs a known chaotic system. In many practical situations when the external perturbation is unknown, an

*e-mail: nil@prl.ernet.in

†e-mail: amritkar@prl.ernet.in

ansatz function modeling the behaviour of the external perturbation is tried. We show that it is possible to use our parameter estimation method, to confirm the form of an ansatz function modeling the external perturbation.

In section IIA we briefly introduce our method of parameter estimation and discuss its important features. In section IIB we extend it to a general situation when the given time series is obtained as a scalar function of the phase space variables. Section IIC deals with a general quadratic flow in three dimensions. In section III we extend the method to the case of finite time series and present two examples. Finally in section IV we give the application of the method in confirming the form of an unknown external perturbation to a known dynamical system. In section V we conclude with a summary of the results.

II. PARAMETER ESTIMATION

A. The method

Here, we briefly introduce our method for parameter estimation from a scalar time series. We would like to direct the reader to Ref. [2] for a more detailed discussion. We start by considering an autonomous dynamical system of the form,

$$\dot{\mathbf{x}} = \mathbf{f}(\mathbf{x}, \alpha), \quad (1)$$

where $\mathbf{x} = (x_1, x_2, \dots, x_n)$ is an n -dimensional state vector whose evolution is described by the function $\mathbf{f} = (f_1, \dots, f_n)$. We denote a set of m unknown scalar parameters by $\alpha = (\alpha_1, \alpha_2, \dots, \alpha_m)$. A possible appearance of any other parameters (assumed to be known) is not shown in Eq. (1).

Without loss of generality we assume that a time series of the variable x_1 is given. The problem we consider is to estimate α from the given scalar time series of x_1 assuming the functional form of \mathbf{f} to be known.

In analogy with the control method used earlier by John and Amritkar [7,8], we combine synchronization with adaptive control to achieve our goal of estimating α in Eq. (1) as follows. We construct another system of variables \mathbf{x}' having a structure identical to that of Eq. (1) with a linear feedback proportional to the difference $x'_1 - x_1$ added in the evolution of the variable x_1 . Thus the system is given by,

$$\begin{aligned} \dot{x}'_1 &= f_1(\mathbf{x}', \alpha') - \epsilon(x'_1 - x_1) \\ \dot{x}'_j &= f_j(\mathbf{x}', \alpha'), \quad j = 2, \dots, n. \end{aligned} \quad (2)$$

where the function $\mathbf{f} = (f_1, \dots, f_n)$ is the same as that in Eq. (1). The initial values of parameters α' which correspond to the unknown parameters α in Eq. (1) are chosen randomly. The newly introduced parameter ϵ is the feedback constant. It is known that if $\alpha' = \alpha$ then the systems (1) and (2) synchronize after an initial transient,

provided the conditional Lyapunov exponents (CLE's) of the system (2) are all negative [2]. The CLE's are obtained from the eigenvalues of the Jacobian matrix J whose elements are given by,

$$J_{ij} = \frac{\partial f_i}{\partial x_j} - \epsilon \delta_{i1} \delta_{j1} \quad (3)$$

Since the values $\alpha = (\alpha_1, \dots, \alpha_m)$ are unknown, we need to set $\alpha' = (\alpha'_1, \dots, \alpha'_m)$ to random initial values and evolve them *adaptively* so that they converge to the values α . Note that a good guess for the initial values of α' , can be useful in many cases.

We first consider the case when α (and its counterpart α') contains only a single element, i.e. the case when only a single parameter in Eq. (1) is unknown. For notational simplicity we now denote this single parameter by α . We start with a random initial value for α' and evolve it in a controlled fashion so that it converges to α . This is achieved by raising α' to the status of a variable which evolves as,

$$\dot{\alpha}' = -\delta(x'_1 - x_1) w \left(\frac{\partial f_1}{\partial \alpha'} \right), \quad (4)$$

where δ is called stiffness constant and w is some suitably chosen function of $\partial f_1 / \partial \alpha'$. A simple choice for w is $w = \partial f_1 / \partial \alpha'$ giving the adaptive evolution equation for α' as,

$$\dot{\alpha}' = -\delta(x'_1 - x_1) \frac{\partial f_1}{\partial \alpha'}. \quad (5)$$

Eq. (4) or Eq. (5) when coupled with Eq. (2) constitutes our method of parameter estimation. A vector (\mathbf{x}', α') initially set to random values asymptotically converges to a vector (\mathbf{x}, α) in Eq. (1) provided the conditional Lyapunov exponents (CLE's) for the combined system (Eqs. (2) and (5)) are all negative. This facilitates the estimation of α .

Eq. (5) is equivalent to a dynamic algorithm for minimization of synchronization error between Eqs. (1) and (2) as discussed in Ref. [2].

Note that if we assume in the above discussion that the unknown parameter α appears in the function f_1 corresponding to the variable x_1 for which the time series is given then the calculation of the factor $\partial f_1 / \partial \alpha'$ in Eq. (5) is straightforward. However this may not be necessarily the case. The parameter α may appear in any of the other system functions. If it appears in the functions for the variables for which the time series is not given, e.g. in any of the functions f_2, \dots, f_n in Eq. (1), then correspondingly the calculation of the factor $\partial f_1 / \partial \alpha'$ becomes nontrivial.

To make this point clear we assume that the unknown parameter α appears in the function $f_k(\mathbf{x})$ governing the evolution of variable x_k with $k \neq 1$ while the time series of x_1 is given. In such a case Eq. (5) gets modified to, (See Ref. [2])

$$\dot{\alpha}' = -\delta(x'_1 - x_1) \frac{\partial f_1}{\partial x'_k} \frac{\partial f_k}{\partial \alpha'}. \quad (6)$$

Further if the variable x_k itself does not appear in the function f_1 then the complexity of the calculation still increases. This issue has been explained in detail with an example in Ref. [2].

Next we consider the case when the set α of unknown parameters contains more than one element, say $(\alpha_1, \alpha_2, \dots)$. Now we set up an adaptive evolution for each of the corresponding parameters $(\alpha'_1, \alpha'_2, \dots)$. For the case of two unknown parameters α_1 and α_2 , appearing in functions f_k and f_l respectively, the adaptive evolution is given by,

$$\begin{aligned} \dot{\alpha}'_1 &= -\delta_1(x'_1 - x_1) \frac{\partial f_1}{\partial x'_k} \frac{\partial f_k}{\partial \alpha'} \\ \dot{\alpha}'_2 &= -\delta_2(x'_1 - x_1) \frac{\partial f_1}{\partial x'_l} \frac{\partial f_l}{\partial \alpha'}, \end{aligned} \quad (7)$$

where δ_1 and δ_2 are two stiffness constants deciding the rates of convergence. For estimating the values of α_1 and α_2 Eqs. (7) can be coupled with Eqs. (2) which provide the necessary synchronization of system variables if the associated CLE's are negative.

In the next subsection we extend our method to a situation when a time series of a *scalar function* of phase space variables is given. We show that it is not only possible to build a synchronizing system but also to adaptively estimate an unknown parameter.

B. Parameter estimation using time series of a scalar function of variables

In our discussion of parameter estimation in earlier subsection, we have assumed that time series of one of the phase space variables is given. This may not be the case in many practical applications and in general the observed quantity can be a function of the phase space variables, say $s(\mathbf{x})$. It is possible to construct a synchronization scheme in such a situation [16].

We consider the system given by Eq. (1) and assume that the time series $s(\mathbf{x})$ which is a function of phase space variables is given. A synchronization scheme can be set up in this case by using a suitable modification of the feedback in Eq. (2) as follows [16].

$$\begin{aligned} \dot{x}'_1 &= f_1(\mathbf{x}', \alpha) - \epsilon \operatorname{sgn} \left(\frac{\partial s'}{\partial x'_1} \right) (s' - s(\mathbf{x})) \\ \dot{x}'_j &= f_j(\mathbf{x}', \alpha) \quad j = 2, \dots, n. \end{aligned} \quad (8)$$

where $s' = s(\mathbf{x}')$ and we give a feedback proportional to $(s' - s)$ in the function f_1 with feedback constant ϵ . The function $s(\mathbf{x})$ denotes the given time series.

It can be shown that if the parameters α are assumed to be known, the above system of equations for

x' (Eqs.(8)) converges to x , provided the CLE's are all negative [16].

In Eqs. (8), we have assumed that $s(\mathbf{x})$ has an explicit dependence on the variable x_1 so that $\partial s'/\partial x'_1 \neq 0$. If this is not the case, we can choose any other variable for the feedback on which $s(\mathbf{x})$ depends explicitly. The factor $\operatorname{sgn}()$ in Eq. (8) makes sure that the term provides a 'negative feedback' for all the time so that a convergence is feasible.

To estimate parameter α in such a case, we set up a synchronization scheme combined with an adaptive control in analogy with Eqs. (2) and (4). This system can be written as,

$$\begin{aligned} \dot{x}'_1 &= f_1(\mathbf{x}', \alpha) - \epsilon \operatorname{sgn} \left(\frac{\partial s'}{\partial x'_1} \right) (s' - s(\mathbf{x})) \\ \dot{x}'_j &= f_j(\mathbf{x}', \alpha) \quad j = 2, \dots, n. \\ \dot{\alpha}' &= -\delta \operatorname{sgn} \left(\frac{\partial s'}{\partial x'_1} \right) (s' - s(\mathbf{x})) \frac{\partial f_1}{\partial \alpha'}. \end{aligned} \quad (9)$$

Eqs. (9) can be used for estimating α when a time series of $s(\mathbf{x})$ is given. The condition for such an estimation of α to be possible is that the CLE's associated with the system (9) are all negative.

To demonstrate the above procedure, we consider the Lorenz system given by,

$$\begin{aligned} \dot{x} &= \sigma(y - x) \\ \dot{y} &= rx - y - xz \\ \dot{z} &= xy - bz, \end{aligned} \quad (10)$$

where the variables (x, y, z) define the state of the system while (σ, r, b) are the three parameters. We consider the case when the time series of $s(x, y, z) = 0.5x^2 + 1.1y$ is given as an output of the above system and the parameter σ is unknown.

To estimate the value of σ , we form a system of variables (x', y', z', σ') similar to Eq. (9). The evolution equations are

$$\begin{aligned} \dot{x}' &= \sigma'(y' - x') - \epsilon \operatorname{sgn}(x')(s' - s(x, y, z)) \\ \dot{y}' &= rx' - y' - x'z' \\ \dot{z}' &= x'y' - bz' \\ \dot{\sigma}' &= -\delta \operatorname{sgn}(x')(s' - s(x, y, z))(y' - x'), \end{aligned} \quad (11)$$

where $s' = 0.5x'^2 + 1.1y'$.

Figures 1(a)-(d) show the evolution of the differences $x' - x, y' - y, z' - z, \sigma' - \sigma$ respectively (Eqs. (10) and (11)) as a function of time t . We see that these differences all go to zero as $t \rightarrow \infty$. This indicates that an unknown σ can be estimated using Eq. (11).

The CLE's are obtained using the Jacobian matrix J given by

$$J = \begin{pmatrix} -\sigma - \epsilon \operatorname{sgn}(x)x & \sigma - 1.1\epsilon \operatorname{sgn}(x) & 0 & y - x \\ r - z & -1 & -x & 0 \\ y & x & -b & 0 \\ -\delta \operatorname{sgn}(x)x(y - x) & -1.1\delta \operatorname{sgn}(x)(y - x) & 0 & 0 \end{pmatrix} \quad (12)$$

We have verified that all the CLE's are less than zero except one trivial CLE which is zero.

We have performed simulations and successfully estimated unknown parameters in Lorenz system with other forms of the function $s(x, y, z)$. The function $s(x, y, z)$ should however be such that all the associated conditional Lyapunov exponents should be negative.

C. A general quadratic flow in 3-D

Now we consider a quadratic flow in 3-D given by,

$$\begin{aligned} \dot{x} &= a_0 + a_1x + a_2y + a_3z + a_4x^2 + a_5y^2 \\ &\quad + a_6z^2 + a_7xy + a_8yz + a_9xz \\ \dot{y} &= b_0 + b_1x + b_2y + b_3z + b_4x^2 + b_5y^2 \\ &\quad + b_6z^2 + b_7xy + b_8yz + b_9xz \\ \dot{z} &= c_0 + c_1x + c_2y + c_3z + c_4x^2 + c_5y^2 \\ &\quad + c_6z^2 + c_7xy + c_8yz + c_9xz, \end{aligned} \quad (13)$$

where $(a_0, \dots, a_9, b_0, \dots, b_9, c_0, \dots, c_9)$ form a thirty dimensional parameter space and (x, y, z) are the three variables. We have performed simulations in which we have assumed more than one of the thirty parameters of the system (13) to be unknown and tried to estimate them when a time series of one of the variables is given.

To elaborate, we assume some of the thirty parameters to be unknown while the remaining to be known. Some of the known or unknown parameters may be zero thereby making the corresponding term absent from the system. To illustrate the procedure we consider a case when three parameters (a_1, a_2, a_7) are unknown and a time series of x is given, we set up a system of equations similar to Eq. (2) with the adaptive control loops similar to Eq. (7) for the three parameters (a'_1, a'_2, a'_7) as,

$$\begin{aligned} \dot{a}'_1 &= -\delta_1(x' - x)x' \\ \dot{a}'_2 &= -\delta_2(x' - x)y' \\ \dot{a}'_7 &= -\delta_3(x' - x)x'y'. \end{aligned} \quad (14)$$

Eqs. (14) when coupled to the system of variables (x', y', z') with an identical structure of evolution as Eq. (13) with a feedback term in the evolution of x' , can provide the necessary estimation of parameters when the CLE's associated with the reconstructed system are all negative.

In Fig.2(a)-(c) we plot the time evolution of the differences $a'_1 - a_1, a'_2 - a_2, a'_7 - a_7$ as a function of time. The correct value of a_7 was zero while the other two were non-zero. All the differences go to zero indicating the feasibility of simultaneous estimation of the three parameters (a_1, a_2, a_7) even when the actual value of one of them is zero. This shows that the method does not falsely detect a term which is absent in the system.

We have found cases when our method can be used successfully for the system (13) to simultaneously estimate as many as five parameters. (One such case is the

set of parameters a_1, a_2, a_7, b_3, c_1 , while the time series of x is given.)

Further we have also found that when *any* two of the thirty parameters in the system (13) are unknown, we can apply our method to simultaneously estimate them asymptotically *to any desired accuracy* when the time series of a suitably chosen variables is given. Our results suggest that the information about all the thirty parameters should in principle be contained in the time series of a single variable of the system, though at present we do not have any systematic approach to the simultaneous estimation of all of them.

III. PARAMETER ESTIMATION USING A FINITE TIME SERIES

A. Algorithm for repetitive use

In this section we discuss an algorithm for repetitive use of our method to improve the accuracy of parameter estimation when the given time series is of finite duration.

Before going on to describe the algorithm it should be mentioned here that even if a finite time series is used repeatedly, we do not expect an exact estimation of the unknown parameter. A finite chaotic trajectory sets a limit on the accuracy to which the unknown parameter can be estimated. This can be seen as follows :

We consider symbolic dynamics on the attractor which provides a generating partition of the attractor. It is well known that as the system evolves in time, a finer and finer coarse graining is required to specify a particular trajectory or alternatively, the trajectory gives us a finer coarse grained information about the attractor. The number of coarse grained partitions as a function of time goes as,

$$n_p \sim \exp\{ht\}, \quad (15)$$

where h is the Kolmogorov entropy [17].

If ξ^d is the volume of a hypercube in a d dimensional phase space and if the size of the attractor is normalized to unity, the number of hypercubes in a generating partition may be approximated as,

$$n_p \sim \frac{1}{\xi^d}. \quad (16)$$

Equations (15) and (16) indicate that the length scale of a hypercube in a generating partition goes as,

$$\xi \sim \exp\left\{-\frac{h}{d}t\right\}. \quad (17)$$

It can be seen from Eq. (17) that as long as t is finite, the volume of the hypercube in a coarse graining of the attractor will not reduce to zero. Thus a finite trajectory sets a limit on the accuracy to which any information can be extracted from it. This can be further related

to Lyapunov exponents using the famous Kaplan-Yorke conjecture [18] as,

$$\xi \sim \exp\left\{-\frac{\sum_{\lambda>0} \lambda}{d} t\right\}, \quad (18)$$

where λ is the characteristic Lyapunov exponent of the system. For a chaotic system with a single positive Lyapunov exponent denoted by λ^+ , eqn. (18) reduces to,

$$\xi \sim \exp\left\{-\frac{\lambda^+}{d} t\right\}. \quad (19)$$

Now we will discuss the algorithm for repetitive use of a finite time series to estimate an unknown parameter. Similar to the case considered in section IIA, we assume that the parameters $\alpha = (\alpha_1, \alpha_2, \dots, \alpha_m)$ in Eq.(1) are unknown while the time series of x_1 is given. We further assume that the time series is truncated after a finite time T .

For the time interval $0 \leq t \leq T$, we can use the procedure identical to that described earlier (Eqs. (2) and (5)) to evolve variables (\mathbf{x}', α') with random initial conditions. The given finite time series is fed in system (2) as in the earlier case. In this way we can get an approximate value of α which we denote as, $\alpha^1 = \alpha'(T)$.

Now at time $t = T$ we set the variables \mathbf{x}' to exactly the same (randomly chosen earlier) initial values while $\alpha' = \alpha^1$ and feed the same finite time series $\{x(t)|0 \leq t \leq T\}$ again into the system (2) through the feedback terms in Eqs. (2) and (5), i.e. we set $x(t+T) = x(t)$. We now evolve the variables (\mathbf{x}', α') for the time interval $T \leq t \leq 2T$ to obtain a new estimated value of α which is $\alpha^2 = \alpha'(2T)$.

We repeat the procedure to get successive estimates for the value of α denoted by $\alpha^1, \alpha^2, \alpha^3, \dots, \alpha^N, \dots$ at times $t = T, 2T, 3T, \dots, NT, \dots$ respectively. Thus, starting from an initial guess for the value of α we obtain a sequence of estimates $\alpha^0, \alpha^1, \dots, \alpha^N$ after N usages of the given finite time series. For large enough N we get a better and better estimate of α , although eventually the accuracy of such an estimate saturates as N is increased further.

The conditions for the method of parameter estimation using a finite time series to work successfully are :

1. The conditional Lyapunov exponents associated with the reconstructed system should be all negative.
2. The time T after which the given time series is truncated should satisfy $T > \tau$ where τ denotes the transient time required for synchronization of the systems (1) and (2) with the parameter evolution given by Eq. (5).

In the next subsection, we discuss two examples of parameter estimation from a finite time series, viz. Lorenz system and an electrical circuit of a phase converter.

B. Examples

1. Lorenz system

As our first example we choose the Lorenz system given by Eq. (10) where we assume that the time series $\{x(t)|0 \leq t \leq T\}$ is given and the value of σ is to be estimated. We set up the following system of equations (see Eqs. (2) and (5)).

$$\begin{aligned} \dot{x}' &= \sigma(y' - x') - \epsilon(x' - x) \\ \dot{y}' &= rx' - y' - x'z' \\ \dot{z}' &= x'y' - bz' \\ \dot{\sigma}' &= -\delta(x' - x)(y' - x') \end{aligned} \quad (20)$$

where we feed the given time series in the evolution of x for the interval $0 \leq t \leq T$ to obtain the first estimate σ^1 .

As described in the earlier subsection, we then go on repetitively feeding the same finite time series $x(t)$ in Eq.(20) to obtain successive estimates for the value of σ . Starting from a random initial value we denote this sequence of estimates by $\sigma^0, \sigma^1, \dots, \sigma^N$ where N denotes the number of times we use the given time series.

In Fig.3 we plot the evolution of the difference $\sigma' - \sigma$ as a function of time t during the time interval $0 \leq t \leq 3T$ where we use the time series $x(t)$ thrice. We see that the difference decreases as we increase the number of times the finite time series is used. We also observe that shortly after each resetting of the initial vector (x', y', z') which is done at times $T, 2T$, the synchronization weakens and fluctuations are present. This is due to the random resetting of the y and z components which gives a transient before the synchronization is recovered. An appropriate feedback constant ϵ may be chosen to lessen this transient in every usage of the time series.

In Fig.4 we plot the successive differences $\sigma^N - \sigma$ as a function of N , the number of times we use the given finite time series. We see that the difference $\sigma^N - \sigma$ goes on decreasing with increasing N . However, as N is increased further, it saturates to a constant finite value depending on the length of the time series used for the calculations. This is consistent with our expectations that finite time series can contain only finite information about the system as discussed in the previous subsection, e.g. using $\lambda^+ \sim 0.9$, the finest length scale that can be obtained using a finite time series with $T = 30$ is estimated to be 0.05 (Eq. (19)) which means an accuracy of about 10^{-3} . This is also the order of magnitude of the accuracy of parameter estimation.

The three curves in Fig. 4 correspond to three different values of $T = T_1 < T_2 < T_3$. We see that an increasing T gives better estimate of the parameter. This is natural since a very long time series corresponding to $T \rightarrow \infty$ is expected to give an exact estimation of the unknown parameter.

We have similarly implemented our method to estimate other parameters of Lorenz system using finite time series of either x or y . The method fails to estimate any of the parameters when the time series of z is given. The reason for this is that one of the associated conditional Lyapunov exponents is critically zero and the convergences are slow.

2. A phase converter circuit

As our next example, we consider the set of equations describing an electrical circuit for a phase converter [19] system in a dimensionless form given by,

$$\begin{aligned} \dot{x}_1 &= x_2 \\ \dot{x}_2 &= -kx_2 - \frac{x_1}{4} (x_1^2 + 3x_3^2) \\ \dot{x}_3 &= x_4 \\ \dot{x}_4 &= -kx_4 - \frac{x_3}{4} (x_1^2 + 3x_3^2) + B \cos t \end{aligned} \quad (21)$$

where k and B are the two parameters. Here we consider the time series $\{x_2(t) | 0 \leq t \leq T\}$ to be given. Notice that the system (21) has a simple time dependent term making it a non-autonomous system. Such a system is equivalent to an autonomous system in higher dimensions. We have successfully estimated any one of the parameters k or B (or both) using finite time series of $x_2(t)$.

Figure 5(a) shows a schematic diagram of the circuit for the phase converter. The system is known to exhibit a chaotic behaviour due to period doubling bifurcations, codimension two bifurcations etc. Figure 5 (b) shows a chaotic attractor in the $x_1 - x_2$ plane of the phase space.

Figure 6 shows the plot of the successive differences $k^N - k$ as a function of N , the number of times we use the given time series for two different values of the truncation time T . As expected the accuracy of the estimation increases with increasing T while showing a saturation with increasing number of repeated usages.

Thus, we have shown how the method of parameter estimation can be used when a finite time series is given. The method works when the CLE's associated are all negative and the time series given is of longer duration than the transient time required for synchronization.

IV. FORM OF A MODEL PERTURBATION

Here we describe an interesting application of our method to test a function modeling an unknown external source of perturbation to a known chaotic system. In many practical situations when an external source of disturbance is not known, a trial function is used to model the perturbation.

We imagine a situation when it is required to verify a proposed trial model form for the perturbation. We denote the actual perturbation by a function $F(\mathbf{x}, \mu)$ and

the trial function by $G(\mathbf{x}', \mu')$ where μ and μ' are parameters. In the following, we demonstrate the use of our method of parameter estimation to confirm the form of the trial function. Note that here we do not deal with the issue of obtaining the form of the model function.

Now if the proposed trial function G models the external perturbation F correctly, then a scheme based on synchronization combined with adaptive control should produce synchronization of variables and make the parameters μ' converge (to μ). Thus a successful synchronization should then indicate a correctly chosen model function. In this manner we can use the method to distinguish between a correct model and a wrong model for an external perturbation. We elaborate on this application further using the example of Lorenz system.

Consider the Lorenz system perturbed by a sinusoidal term $F = A \sin(\omega x)$,

$$\begin{aligned} \dot{x} &= \sigma(y - x) + A \sin(\omega x) \\ \dot{y} &= rx - y - xz \\ \dot{z} &= xy - bz, \end{aligned} \quad (22)$$

where we assume the unperturbed Lorenz system to be known. The function $F = A \sin(\omega x)$ is the external perturbation. We assume that the time series of x is given as an output of the system (22).

To set up the required scheme we construct a system of variables (x', y', z') and their evolution as,

$$\begin{aligned} \dot{x}' &= \sigma(y' - x') + G(x', y', z', \mu') - \epsilon(x' - x) \\ \dot{y}' &= rx' - y' - x'z' \\ \dot{z}' &= x'y' - bz', \\ \dot{\mu}' &= -\delta(x' - x) \frac{\partial G}{\partial \mu'}. \end{aligned} \quad (23)$$

where $G(x', y', z')$ is the trial perturbation function.

We feed the time series $x(t)$ obtained from system (22) into the model system (23). Now if G models the behaviour of F correctly then the two systems should exhibit synchronization while the parameters should show convergence to the correct values. In our simulations we have tried several different forms for the trial function G .

Figures 7(a)-(c) show the time evolution of $x' - x$, μ_1 and μ_2 respectively while the feedback is given into x and the trial function is $G = \mu_1 x^2 + \mu_2$. It can be clearly seen that there is no synchronization of variables. The trial function $G = \mu_1 x^2 + \mu_2$ thus fails to produce synchronization and hence can be discarded as a plausible model for F . We also note that the parameters μ'_1 and μ'_2 do not show convergence.

In Figs. 8 and 9, we plot similar graphs for two more choices of the trial function. In Fig. 8(a)-(c) we use $G = \mu_1 x - \mu_2 x^3$ and plot $x' - x$, μ_1 and μ_2 respectively. We choose this form of G since it represents the two leading terms in the series expansion of the the function $F = A \sin(\omega x)$. We can see from Fig. 8 that such an approximation fails to produce synchronization and also the convergence of parameters.

As a third choice we use $G = \mu_1 \sin(\mu_2 x)$ in Eq. (23) and plot the time evolution of $x' - x$, μ_1 and μ_2 in Fig.9(a)-(c) respectively. The difference $x' - x$ goes to zero as time increases showing synchronization. The parameters μ_1 and μ_2 converge to the correct values A and ω respectively. The variables y' and z' also synchronize with y and z respectively. This confirms that this trial function correctly models the function F .

Now as a last consideration, we use the form $G = \mu_1 \sin(\mu_2 x)$ again but unlike in Eq. (23) we perturb a wrong variable in the model system, i.e. we choose to add the trial perturbation in the evolution of say y' . The feedback is given in x . The evolution equations are

$$\begin{aligned}\dot{x}' &= \sigma(y' - x') - \epsilon(x' - x) \\ \dot{y}' &= rx' - y' - x'z' + G(x', y', z', \mu') \\ \dot{z}' &= x'y' - bz', \\ \dot{\mu}' &= -\delta(x' - x) \frac{\partial G}{\partial \mu'}.\end{aligned}\quad (24)$$

In Fig.10 (a)-(c) we plot the time evolution of $x' - x$, μ_1 and μ_2 respectively. We see that even if G correctly models F , synchronization does not take place. This shows that along with the form of F we can also confirm a guess about the perturbed variable.

Thus, the results presented in this section suggest that the method which we use for estimating parameters can be used to distinguish between a correct trial function and the wrong trial functions for an unknown external perturbation to a known system [20].

V. SUMMARY AND CONCLUSIONS

We have described dynamic method of parameter estimation from a given chaotic time series of a phase space variable of a dynamical system [2]. Further, We have generalized the method for the case when the quantity for which the time series is given is a *scalar function* of the phase space variables. We have shown that it is not only possible to synchronize two systems using the time series of the scalar function but also to asymptotically estimate unknown parameters adaptively to any desired accuracy. This is done by providing a linear feedback in the evolution of one of the variables on which the scalar function explicitly depends. The method works successfully provided the function for which the time series is given is such that the associated conditional Lyapunov exponents are all negative.

We have also applied our method to a system with a large number of parameters, i.e. a general quadratic flow in 3-D. We have observed that a simultaneous estimation of a few parameters is possible provided the condition of convergence as stated in Ref. [2] is satisfied i.e. all the CLE's are negative.

As a next consideration, we have extended our method to a realistic situation when the given series is truncated

after a finite time. We have shown that repetitive use of a finite time series can be made to estimate an unknown parameter of the system. The accuracy of the parameter estimation saturates as the given finite time series is used more and more number of times. The accuracy increases with the increasing length of the given time series.

In the end we have demonstrated an important application of our method in confirming the correctness of a trial model function for an unknown external perturbation to a known system. We see that a perfect synchronization between a perturbed system and its dynamical copy using a model for the perturbation is possible only when the form of the trial function is correctly guessed. These results indicate that our method can be used as a test for the trial model for an unknown external perturbation to a known system. Another possible application (not discussed in the paper) is as follows. Our method may be employed to experimentally measure the unknown value of a component added to a known circuit. In such a situation the equations governing the circuit are known, and can be used to estimate the unknown component value accurately. This is feasible due to the asymptotic convergences in our method.

ACKNOWLEDGMENTS

One of the authors (A.M.) would like to thank U.G.C.(India) for financial support.

-
- [1] H. D. I. Abarbanel, R. Brown, J. J. Sidorowich and L. S. Tsimring, Rev. Mod. Phys. **65**, 1331 (1993).
 - [2] A. Maybhatte and R. E. Amritkar, Phys. Rev. E **59**, 284 (1999) and references therein, (chao-dyn/9804005).
 - [3] L. M. Pecora and T. L. Carroll, Phys. Rev. Lett. **64**, 821 (1990).
 - [4] L. M. Pecora and T. L. Carroll, Phys. Rev. A **44**, 2374 (1991).
 - [5] T. L. Carroll and L. M. Pecora, in *Nonlinear dynamics in circuits*, edited by L. M. Pecora and T. L. Carroll (World Scientific, Singapore, 1995) pp. 215
 - [6] B. A. Huberman and E. Lumer, IEEE Trans. Circuits Syst. **37**, 547 (1990)
 - [7] J. K. John and R. E. Amritkar, Int. J. Bifurcation Chaos Appl. Sci. Eng. **4**, 1687 (1994).
 - [8] J. K. John and R. E. Amritkar, Phys.Rev.E **49**, 4843 (1994).
 - [9] U. Parlitz, L. Junge and L. Kocarev, Phys. Rev. E **54**, 6253 (1996).
 - [10] U. Parlitz, Phys. Rev. Lett. **76**, 1232 (1996).
 - [11] G. L. Baker, J. P. Gollub and J. A. Blackburn, Chaos **6**, 528 (1996).
 - [12] X-Z Tang, E. R. Tracy, A. D. Boozer, A. deBrauw and R. Brown, Phys. Lett. A **190**, 393 (1994).

- [13] X-Z. Tang, E. R. Tracy and R. Brown, *Physica D* **102**, 253 (1997).
- [14] C. S. Daw *et.al.*, *Phys.Rev.E* **57**, 2811 (1998).
- [15] J.Goodwin, R.Brown and L.Junge, a preprint available at <http://xxx.lanl.gov/abs/chao-dyn/9811002>.
- [16] A. Maybhate and R. E. Amritkar, unpublished.
- [17] G. Nicolis, *Introduction to Nonlinear Science* (Cambridge University Press, Cambridge, 1995) pp. 213.
- [18] J. Kaplan and J. Yorke in *Functional Differential Equations and Approximation of Fixed Points*, H. O. Peitgen and H. O. Walther,Eds.(Springer Berlin, New York, 1979) pp. 228.
- [19] T. Yoshinaga and H. Kawakami, in *Nonlinear dynamics in circuits*, edited by L. M. Pecora and T. L. Carroll (World Scientific, Singapore, 1995) pp. 111.
- [20] We note that the application of parameter estimation that we have discussed here is fairly general and may not depend on a particular method used to estimate the parameters. Use of alternative methods for parameter estimation, such as those discussed in the introduction may be possible.

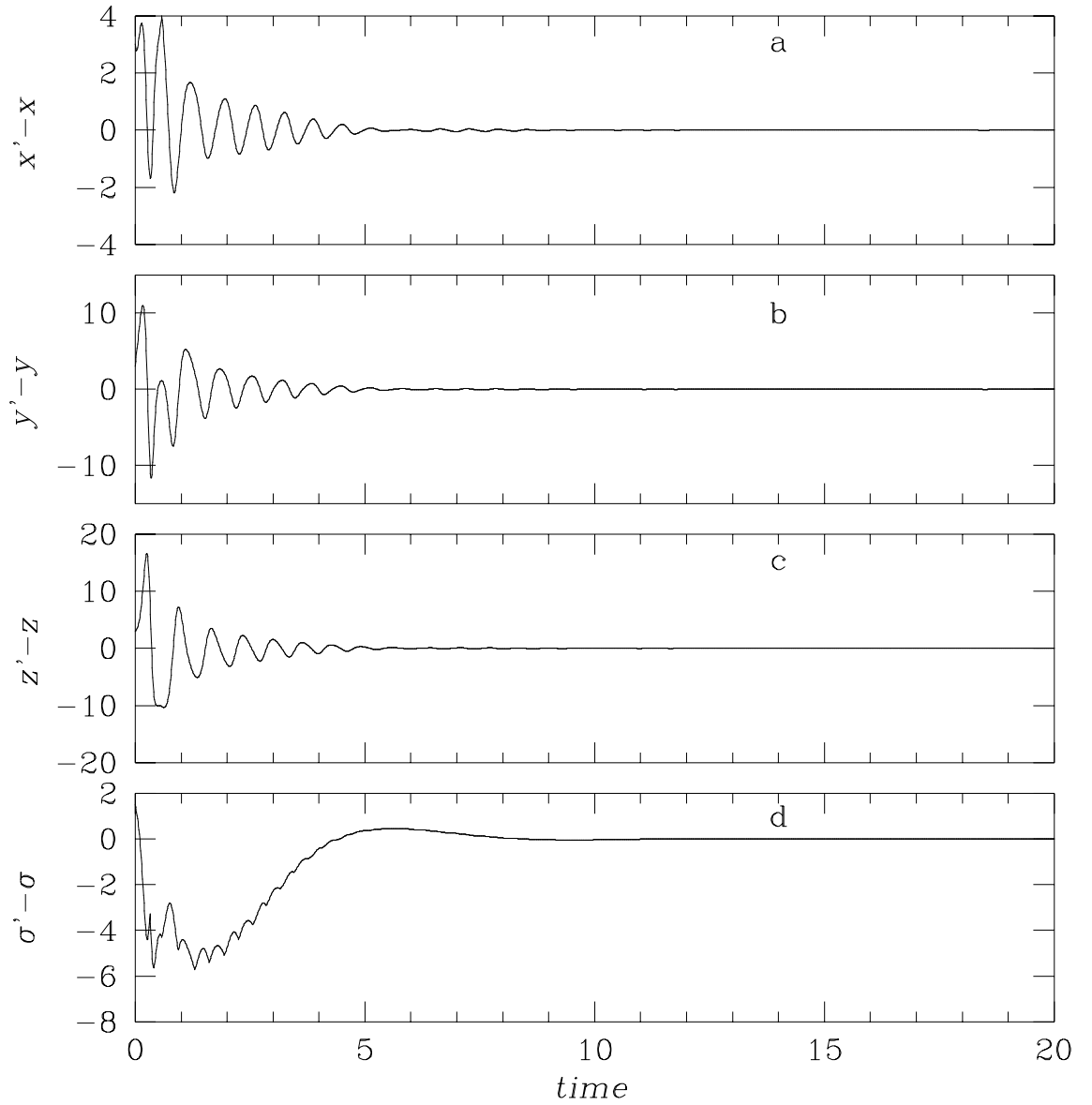

Fig.1

(AM & REA)

FIG. 1. The plots (a)-(d) show the evolution of the differences $x' - x, y' - y, z' - z, \sigma' - \sigma$ as a function of time for the Lorenz system (Eqs. (10) and (11)) respectively for the case when a time series for $s(x, y, z) = 0.5x^2 + 1.1y$ is given and σ is unknown. The differences go to zero asymptotically indicating that it is possible to use our method to estimate an unknown parameter when time series for $s(\mathbf{x})$ is given.

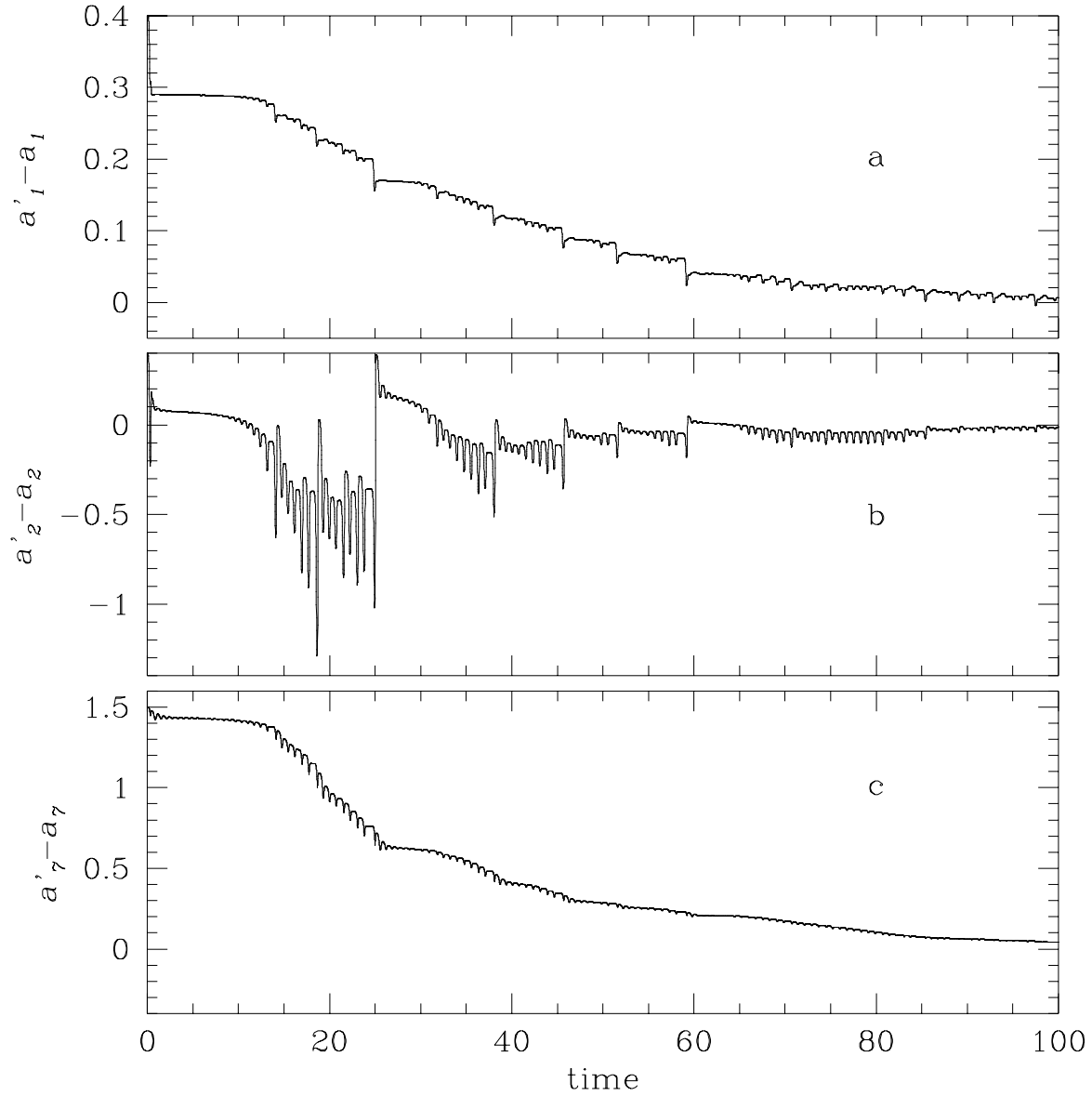

Fig.2

(AM & REA)

FIG. 2. The plots (a)-(c) show the evolution of the differences $a'_1 - a_1, a'_2 - a_2, a'_7 - a_7$ for a general quadratic flow in 3-D (Eq. (13) and (14)), plotted as a function of time when the time series of x is given. We see that all the differences approach zero indicating the feasibility of simultaneous estimation of more than one parameter. The correct value of a_7 was zero, showing that a term absent in the flow equations is not falsely detected by our method.

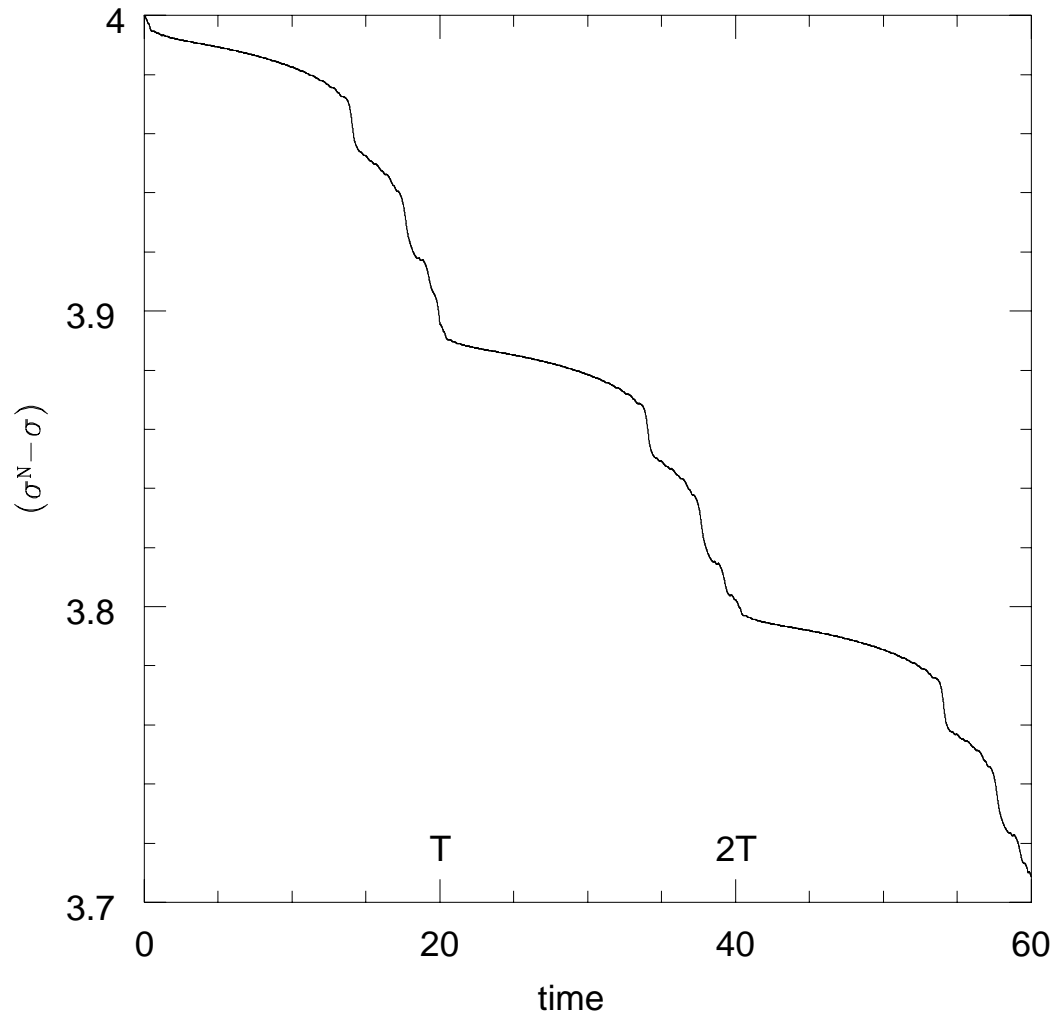

Fig.3 (AM & REA)

FIG. 3. The plot shows the evolution of the difference $\sigma' - \sigma$ as a function of time in the Lorenz system (Eq. (20)) with unknown parameter σ when the given time series of x is truncated after the time $T = 20$. We have used The finite time series thrice and plotted the curve for the interval $0 \leq t \leq 3T$. We see that the successive values of the difference at $t = 0, T, 2T, 3T$ decrease. This indicates that a repetitive use of the finite time series can improve the accuracy of parameter estimation.

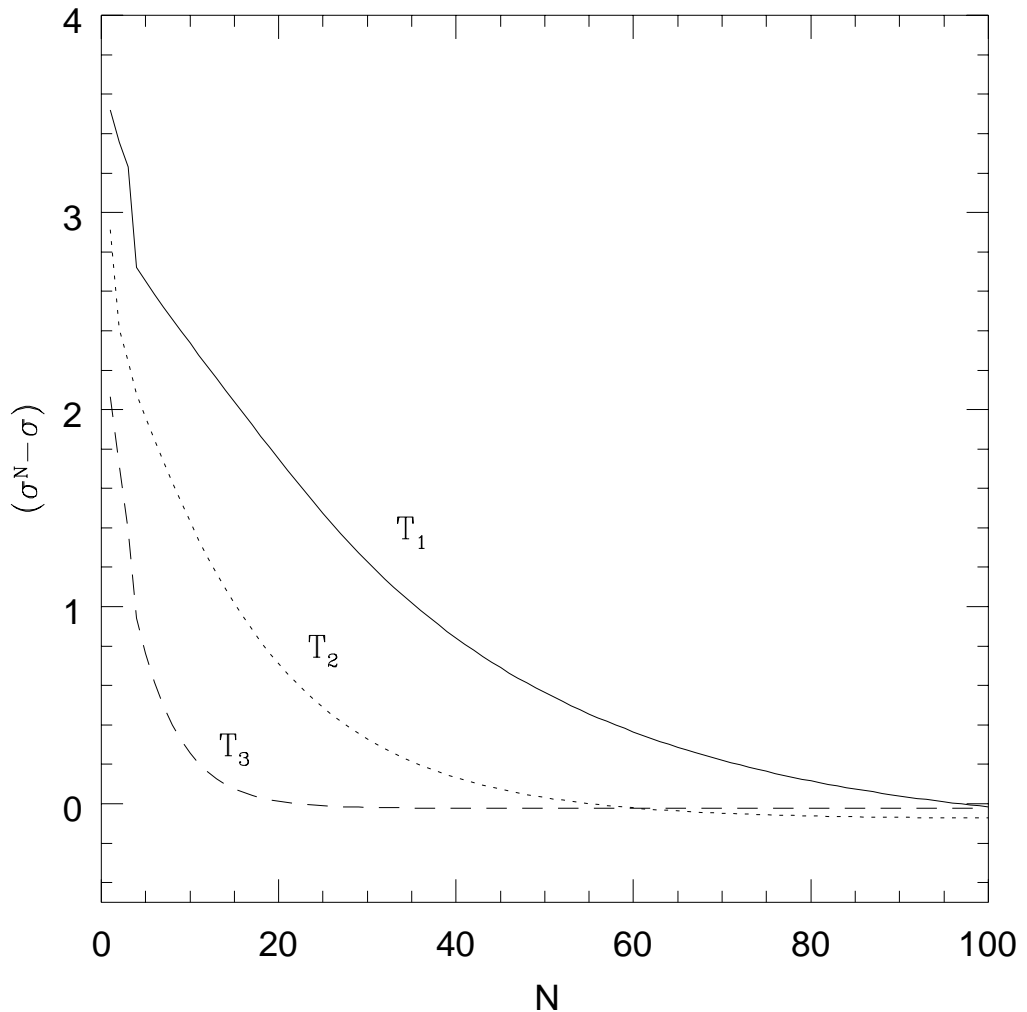

Fig.4

(AM & REA)

FIG. 4. The graph shows the successive differences $\sigma^N - \sigma$ plotted as a function of N , the number of times a finite time series $\{x(t)|0 \leq t \leq T\}$ is used to estimate an unknown σ in a Lorenz system (Eq. (20)). We see that after an initial transient, the difference decreases showing better accuracy of the estimation. We also see that as N increases further the accuracy of estimation saturates and it is not possible to improve upon the estimation beyond this. The three curves correspond to three different values of T where $T_1 < T_2 < T_3$. It can be seen that a larger T leads to a better estimation as expected.

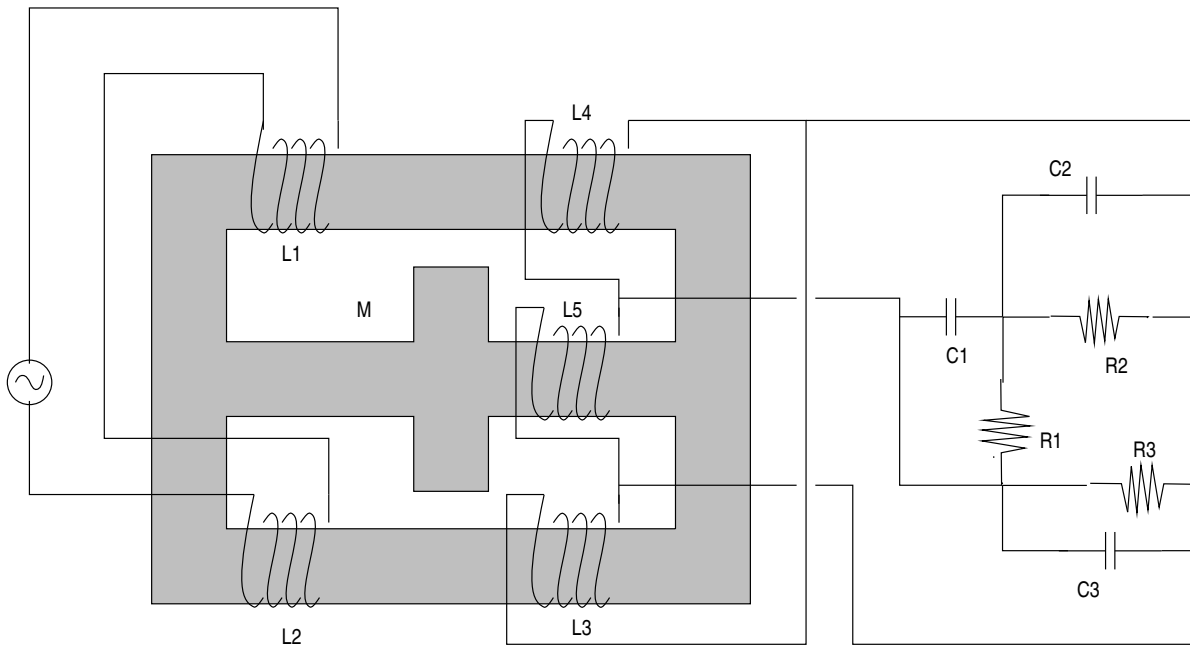

Fig.5(a)

AM & REA

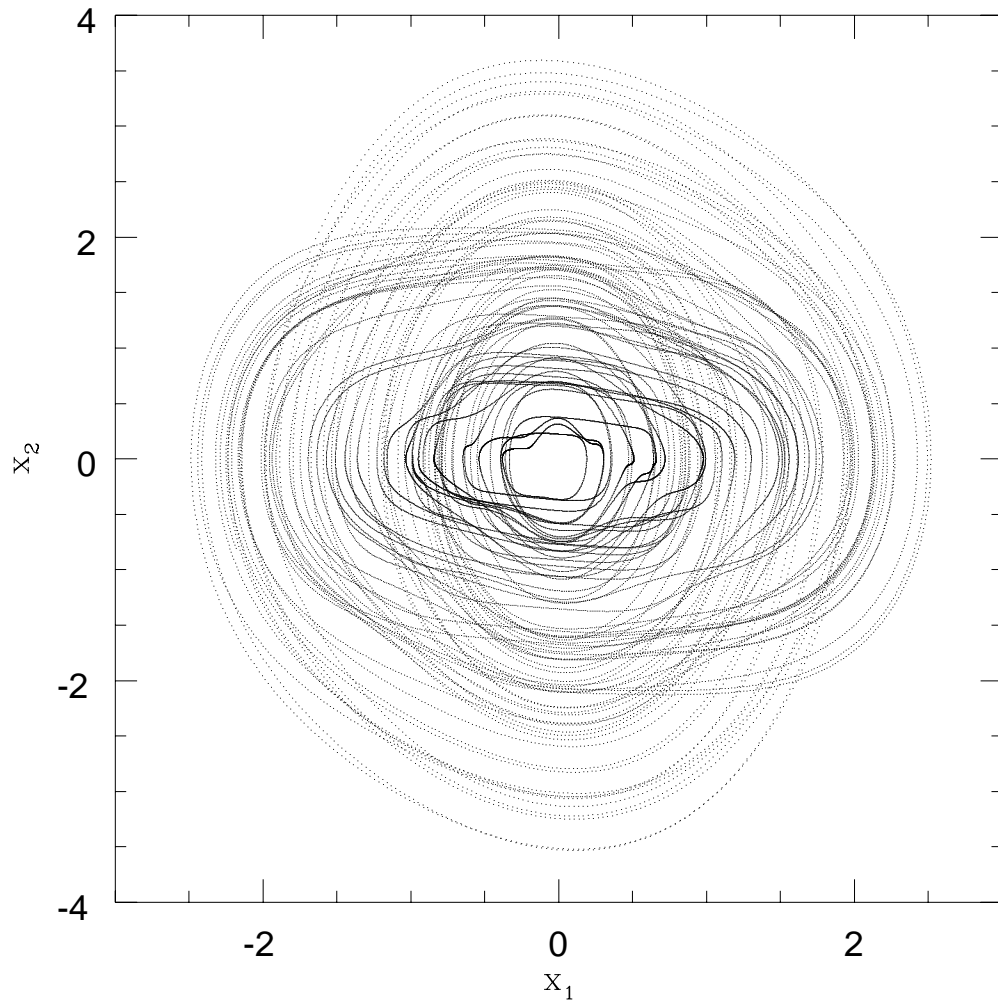

FIG. 5. A schematic diagram (Fig. 5(a)) of a phase converter circuit (Eq. (21)) which shows a chaotic behaviour. Fig. 5(b) shows a chaotic attractor for the parameter values $k = 0.1, B = 3.0$. Fig.5(b) (AM & REA)

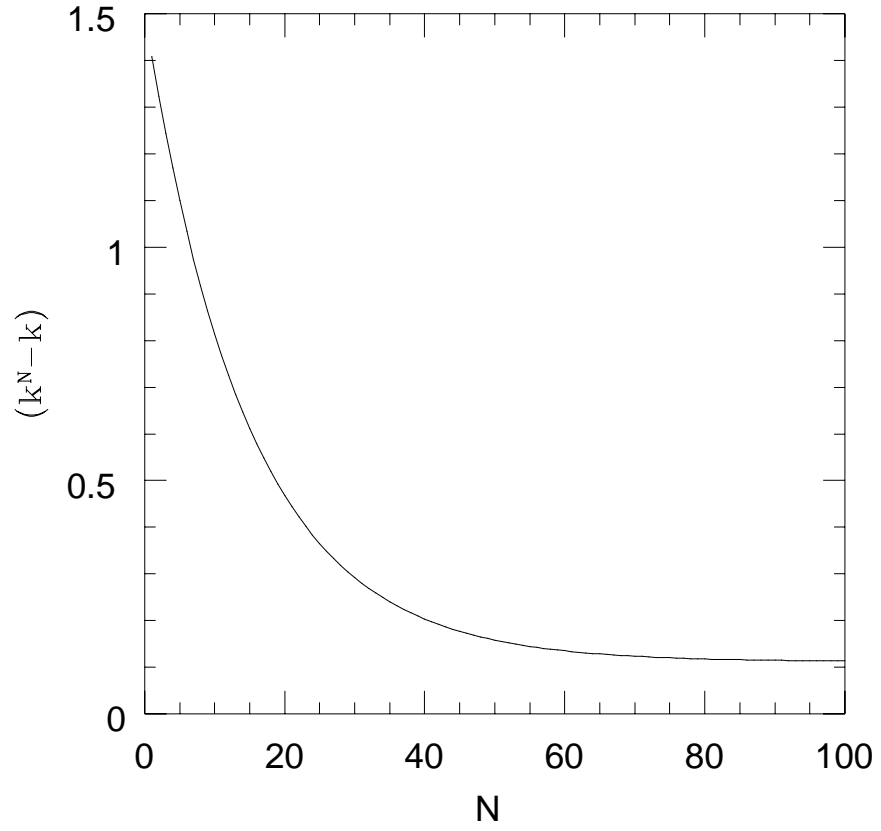

Fig.6

(AM & REA)

FIG. 6. The graph shows the successive differences $k^N - k$ plotted as a function of N , the number of times a finite time series $\{x_2(t)|0 \leq t \leq T\}$ is used to estimate an unknown k in a phase converter circuit system (Eq. (21)). We see that after an initial transient, the difference decreases showing better accuracy of the estimation. We also see that as N increases further the accuracy of estimation saturates and it is not possible to improve upon the estimation beyond this using our method.

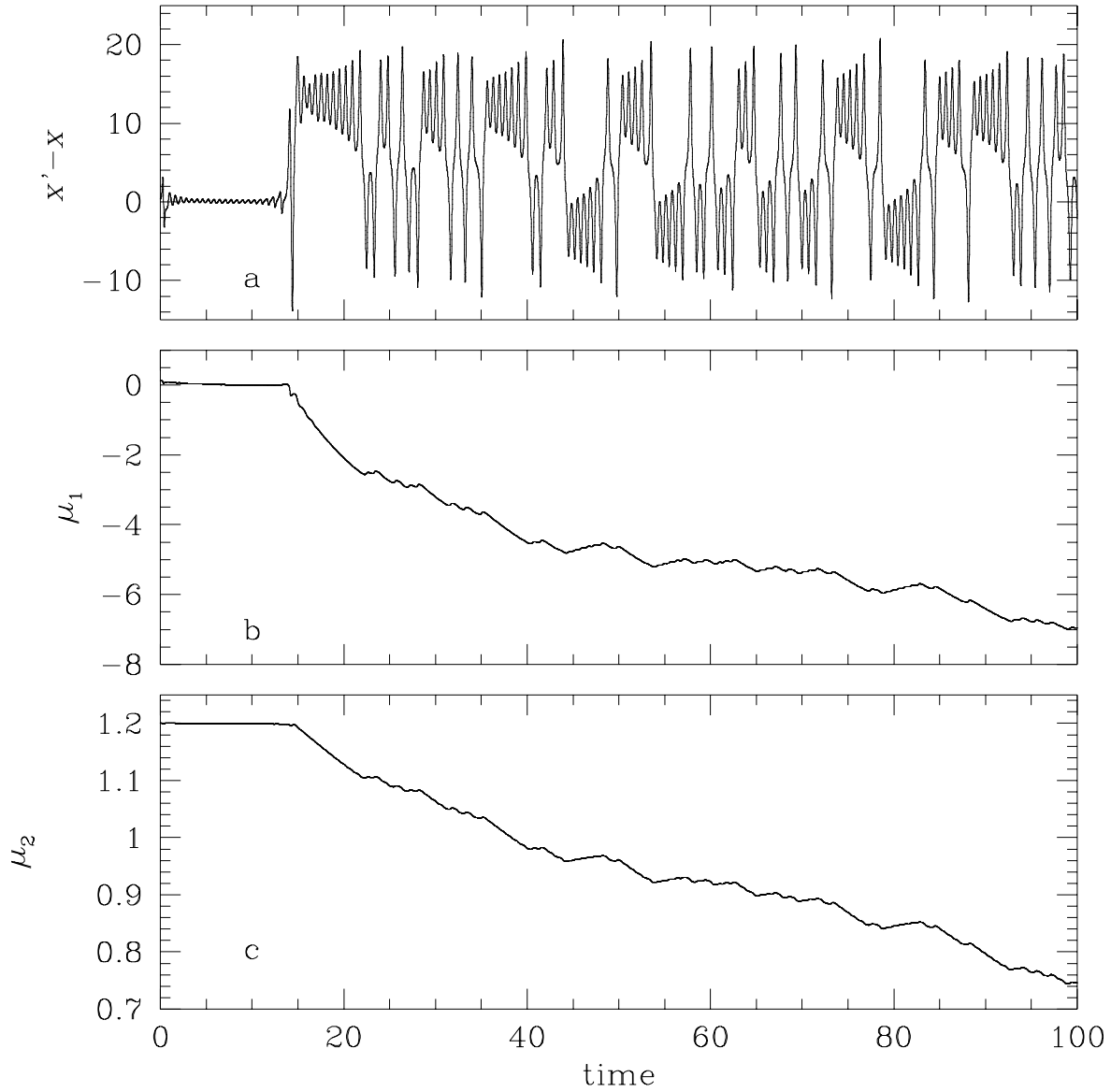

Fig.7

(AM & REA)

FIG. 7. The plots (a)-(c) show the time evolution of $x' - x$, μ_1 and μ_2 respectively for the Lorenz system with the feedback given in equation for x and with the trial perturbation function $G = \mu_1 x^2 + \mu_2$ while the correct perturbation is $F = A \sin(\omega x)$ (Eq. (23)). We see that the guess function $G = \mu_1(Eq. (23))x^2 + \mu_2$ fails to produce synchronization and hence can be discarded as a plausible model for F . It can also be seen that there is no convergence of the parameters taking place.

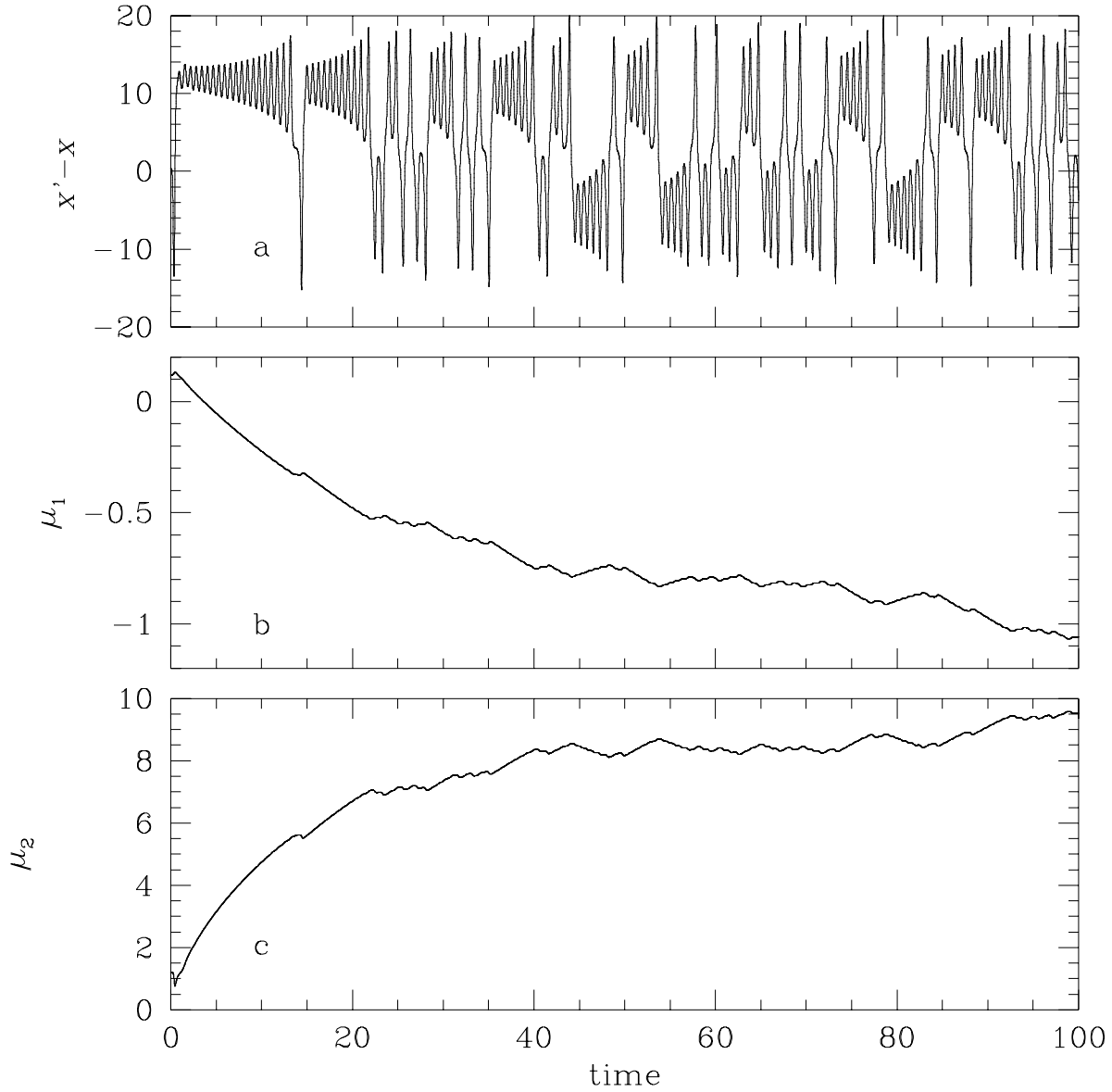

Fig.8

(AM & REA)

FIG. 8. The plots(a)-(c) show the time evolution of $x' - x$, μ_1 and μ_2 respectively for the Lorenz system with the feedback given in equation for x and with the trial perturbation function $G = \mu_1 x + \mu_2 x^3$ while the correct perturbation is $F = A \sin(\omega x)$ (Eq. (23)). It can be clearly seen that even when $G = \mu_1 x - \mu_2 x^3$ matches in form with F upto two leading terms in the expansion of F , it fails to produce synchronization and hence can be discarded as a plausible model for F . Also there is no convergence of the parameters taking place.

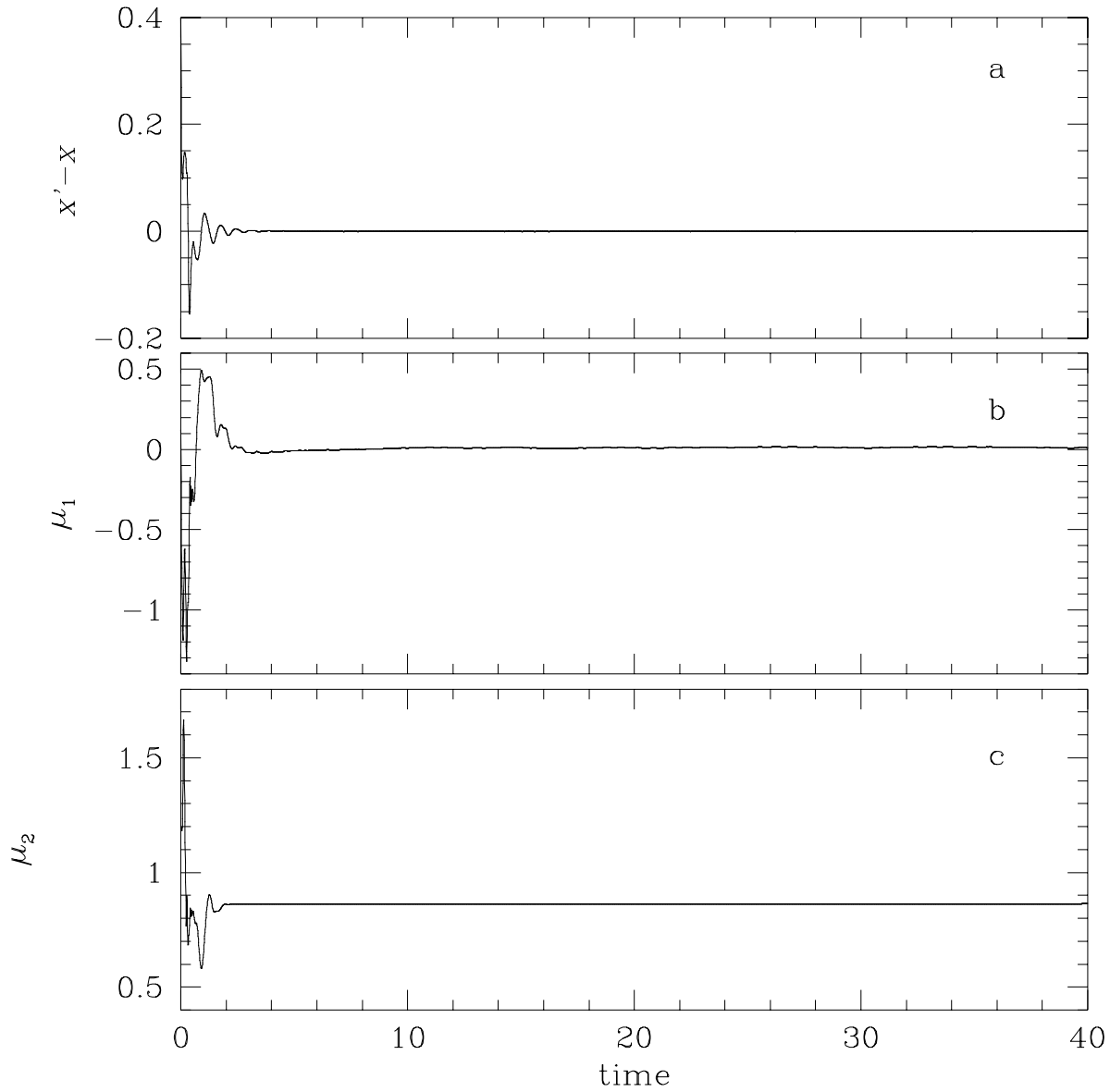

Fig.9

(AM & REA)

FIG. 9. The plots (a)-(c) show the time evolution of $x' - x$, μ_1 and μ_2 respectively for the Lorenz system with the feedback given in equation for x and with the trial perturbation function $G = \mu_1 \sin(\mu_2 x)$ while the correct perturbation is $F = A \sin(\omega x)$ (Eq. (23)). It can be clearly seen that the difference $x' - x$ converges to zero asymptotically indicating an exact synchronization between the variables. Thus by using our method the guess for the model perturbation function can be easily justified.

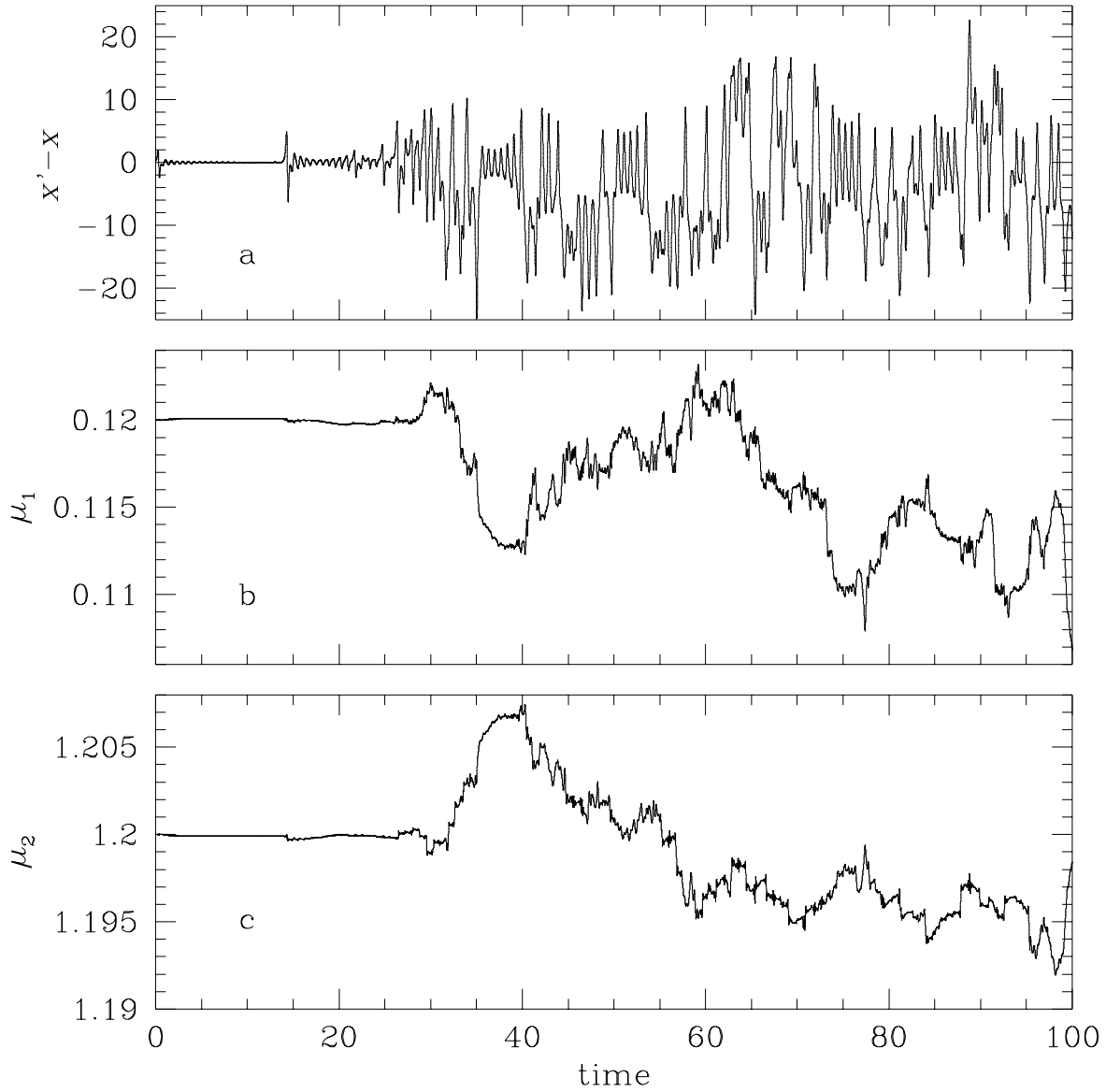

Fig.10

(AM & REA)

FIG. 10. The plots (a)-(c) show the time evolution of the difference $x' - x$ and the parameters μ_1 and μ_2 respectively for the Lorenz system with the feedback given in the equation for x and with the trial perturbation function $G = \mu_1 \sin(\mu_2 x)$ in the equation for y while the correct perturbation is $F = A \sin(\omega x)$ in the equation for x (Eq. (24)). Thus, unlike the case plotted in Fig.9 the trial function used here, perturbs the wrong variable. It can be clearly seen that the trial function G does not produce synchronization between variables. The parameters also do not converge. Thus as expected, the guess function $G = \mu_1(\sin \mu_2 x)$ when added to a wrong variable, cannot model the perturbation.