

Electroweak Baryogenesis and Constraints on Left-handed Majorana Neutrino Masses

Utpal Sarkar¹

Theory Group
Physical Research Laboratory
Ahmedabad - 380009, India.

Abstract

The lepton number violating interactions generated by the light Majorana neutrinos can erase the primordial baryon asymmetry of the universe during the electroweak phase transition. The Majorana masses of the left-handed neutrinos are constrained to avoid this problem. These constraints do not depend on the $(B-L)$ symmetry breaking mechanism.

¹ e-mail address : utpal@prl.ernet.in

The question of baryogenesis [1] revived when it was noticed that the $SU(2)_L$ anomaly corresponding to the global baryon number is non-vanishing [2] and these interactions may be fast enough to wash out the primordial baryon asymmetry of the universe in the presence of the sphaleron fields [3]. Attempts were then made to generate baryon asymmetry during the electroweak symmetry breaking [4, 5, 6]. Although this approach is extremely elegant, here one needs to protect the generated baryon asymmetry after the phase transition. This puts strong constraint [7] on the mass of the higgs doublets. With the present experimental limit on the higgs mass of about 60 GeV, it is already difficult to save this scenario. If the higgs is found to be heavier than 80 GeV, then one has to look for alternative solution to the baryogenesis problem.

It has been shown that if there is any primordial $(B - L)$ asymmetry that would get converted to a baryon asymmetry of the universe during the electroweak phase transition whereas the $(B + L)$ asymmetry will be washed out. Lepton number violating CP nonconserving decays of the heavy Majorana neutrinos were then found to generate enough $(B - L)$ asymmetry, which could then get converted to baryon asymmetry of the universe during the electroweak phase transition [8].

This makes the study of lepton number violating interaction quite important before the electroweak symmetry breaking. If there is fast lepton number violation before the electroweak symmetry breaking is over, then that would wash out any $(B - L)$ asymmetry. Since $(B + L)$ asymmetry is also washed out by the anomalous processes, there will not be any baryon asymmetry left after the electroweak phase transition. It has been pointed out that the condition that any lepton number violating interactions (such as, $l_L + \phi^\dagger \rightarrow l_L^c + \phi$ through the right handed neutrino N exchange or the lepton number violating N decays) should not be faster than the expansion rate of the universe constraints the mass (M_N) of the heavy neutrinos [9, 10]. Here

l_L are the usual left-handed lepton doublets and ϕ is the doublet higgs scalar field, which breaks the electroweak symmetry at the scale M_W . It was then argued that since, in many models, the Majorana masses of the left-handed leptons are related to the Majorana masses of the right handed neutrinos, they relate this bound on M_N to the Majorana masses of the left-handed neutrinos [9, 10]. If the heavy Majorana neutrinos couple to the left-handed neutrinos through a Yukawa coupling which gives a Dirac mass matrix m_D , then the Majorana mass matrix of the left-handed neutrinos can be given by,

$$m_\nu = m_D^T \frac{1}{M_N} m_D.$$

This is true for the see-saw mechanism of neutrino masses [11]. Although see-saw mechanism of generating light neutrinos is quite natural in the left-right symmetric models [12] and is the most popular model, there exists several other models where light neutrinos are not generated using see-saw mechanism [13, 14, 15].

In this note I shall first argue that existing the bounds on the left-handed neutrinos from baryogenesis are model dependent (even in the framework of see-saw mechanism) and there are several cases, where these bounds are not relevant. Then I point out that the Majorana masses of the left-handed neutrinos can generate lepton number violating processes during the electroweak phase transition, which can constraint the Majorana masses of the left-handed neutrinos directly.

It has already been mentioned in the earlier references [10] that the bound on the Majorana masses of the left-handed neutrinos obtained from an analysis of the bound on the the heavy right handed neutrinos are not valid if some global U(1) symmetry is exactly conserved up to an electroweak anomaly. In addition it is clear that if the left-handed neutrino mass is not related to any heavy neutrinos through see-saw mechanism, then also these bounds on the left-handed neutrinos are not valid. A large class of models fall in this cate-

gory [13, 14]. If the determinant of the heavy neutrino mass matrix vanishes, in that case also one cannot apply the bounds on the left-handed neutrinos.

Over and above these general cases, there are several specific cases even within the framework of see-saw models, where the bound given from an analysis of the bound on the right handed neutrino fails. Consider, for example, a scenario with three generations of right handed neutrinos N_i ($i = 1, 2, 3$). For simplicity we assume the Majorana mass matrix for these particles is diagonal and real $M_N = \text{diag} (M_1, M_2, M_3)$. The part of the lagrangian which controls the neutrino mass matrix is given by,

$$\mathcal{L} = M_\alpha N_\alpha N_\alpha + h_{\alpha i} \overline{N}_\alpha l_{Li} \phi + h.c.$$

where l_{Li} are the left-handed lepton doublets ($i = 1, 2, 3$ is the generation index) and ϕ is the higgs doublets of the standard model which breaks the electroweak symmetry. We also assume the hierarchy $M_1 < M_2 < M_3$, which means that after the decays of the the N_2 and N_3 we are left with only N_1 at the mass scale around M_1 . Whether the decays of N_2 or N_3 has generated any lepton asymmetry or not, if the N_1 decays at equilibrium then this will wash out all lepton asymmetry (in which case one can still have $(B-L)$ asymmetry generated through $\Delta B = 2$ transitions [16] at a later stage). On the other hand if N_1 decays are not very fast so as not to erase any lepton asymmetry or it generates any lepton asymmetry the final amount of asymmetry will not depend on how fast N_2 and N_3 decayed. Hence when any bound on the mass of the heavy neutrinos are discussed it is the bound on M_1 .

Now consider the condition that the decay rate of N_1 is slower than the expansion rate of the universe,

$$\frac{\sum_i |h_{1i}^\dagger h_{1i}|}{16\pi} M_1 < H = 1.7\sqrt{g_*} \frac{T^2}{M_p} \quad \text{at } T = M_1 \quad (1)$$

This gives a bound on the quantity $\frac{\sum_i |h_{1i}^\dagger h_{1i}|}{M_1}$. However, the physical left-handed neutrino masses will depend on the other components of $h_{\alpha i}$ and M_N also.

Consider a very simple example where the matrix $h_{\alpha i}$ is also diagonal, and hence the Dirac mass matrix $m_{\alpha i}^D = h_{\alpha i} \langle \phi \rangle$ is given by,

$$m_{\alpha i}^D = \begin{pmatrix} m_1 & 0 & 0 \\ 0 & m_2 & 0 \\ 0 & 0 & m_3 \end{pmatrix}. \quad (2)$$

The baryogenesis bound reads, $\frac{(m_{11}^D)^2}{M_1} < 10^{-3}$ eV (which is satisfied in most models), whereas the neutrino masses for the second and third generation are, $\frac{(m_{22}^D)^2}{M_2}$ and $\frac{(m_{33}^D)^2}{M_3}$ respectively, which are not constrained.

With the above arguments it is clear that the bounds on the Majorana masses of the left-handed neutrinos, which comes indirectly from the bound on the Majorana masses of the right handed neutrinos, can be avoided in many models. We now try to discuss the question if one can constraint the Majorana mass of the left-handed neutrinos directly. This is possible since during the electroweak phase transition, as soon as the higgs doublets acquires a vacuum expectation value (vev) and the $SU(2)_L$ group is broken, there is no symmetry which can prevent the mass of the left-handed neutrinos. So if lepton number is broken before the electroweak symmetry, then as soon as ϕ acquires a vev the left-handed neutrinos will get a mass (m_ν). This can, in principle, induce lepton number violating processes very fast, which can wash out any primordial ($B - L$) asymmetry, which in addition to the sphaleron processes will wash out all baryon asymmetry of the universe.

Hence any lepton number violating processes due to the Majorana mass of the light neutrinos (m_ν) should be slower than the expansion rate of the universe, otherwise that will wash out any ($B - L$) asymmetry of the universe and hence the baryon asymmetry during the electroweak phase transition. There will be several lepton number violating processes, which will be active

at that time. Consider for example, the process,

$$W^+ + W^+ \rightarrow e_i^+ + e_j^+ \quad \text{and} \quad W^- + W^- \rightarrow e_i^- + e_j^- \quad (3)$$

mediated by a virtual left-handed neutrino exchange as shown in figure 1. Here i and j are the generation indices. Depending on the physical mass (and also on the elements of the mass matrix) of the left-handed Majorana neutrinos these processes can wash out any baryon asymmetry between the time when the higgs acquires a vev and the W^\pm decays out, *i.e.*, between the energy scales 250 GeV and 80 GeV. The condition that these processes will be slower than the expansion rate of the universe,

$$\Gamma(WW \rightarrow e_i e_j) = \frac{\alpha_W^2 (m_\nu)_{ij}^2 T^3}{m_W^4} < 1.7 \sqrt{g_*} \frac{T^2}{M_p} \quad \text{at } T = M_W \quad (4)$$

gives a bound on the Majorana mass of the left-handed neutrinos,

$$(m_\nu)_{ij}^2 < 20 \text{keV}. \quad (5)$$

It can be seen that this bound is on each and every elements of the mass matrix and not on the physical states and independent on the existence of any right handed neutrinos.

In general, a Majorana particle can be described by a four component real field,

$$\Psi_M = \sqrt{\frac{m_\nu}{E_\nu}} [u_\nu (b_\nu + d_\nu^*) e^{(-ip \cdot x)} + v_\nu (b_\nu^* + d_\nu) e^{(ip \cdot x)}] \quad (6)$$

and hence the charged current containing a Majorana field,

$$j_\mu = \bar{\Psi}_l \gamma_\mu (1 - \gamma_5) \Psi_M$$

will have a lepton number violating part. However, this lepton number violating contribution will always be suppressed by a factor (m_ν/E_ν) and hence

the rate of such processes will be suppressed by a factor $(m_\nu/E_\nu)^2$. Thus even the decay of the W^\pm to e and ν will have lepton number violation at a rate,

$$\Gamma(W \rightarrow e\nu) = \frac{\alpha_W}{4} \frac{m_\nu^2 M_W^2}{T^2(T^2 + M_W^2)^{1/2}}.$$

The survival of baryon asymmetry of the universe after the electroweak phase transition again requires this process to be slow enough,

$$\Gamma(W \rightarrow e\nu) < H.$$

This translates to a bound on the Majorana mass of the left handed neutrino,

$$m_\nu < 30 \text{ eV}. \quad (7)$$

Similarly, the decay of the higgs doublet to an electron and an anti-neutrino will also have lepton number violating contribution, but they will be suppressed by the Yukawa coupling constants and cannot give stronger bounds. Similarly scattering processes involving the higgs, like $\phi + \phi \rightarrow l_i + l_j$ (mediated by a virtual left-handed neutrino) will contribute to the evolution of the lepton number asymmetry of the universe, but it will be much suppressed compared to the charged current interactions and hence cannot give stronger bound to the Majorana mass of the left-handed neutrinos.

To summarize I point out that it is possible to constraint the Majorana masses of the left-handed neutrinos directly from the survival of baryogenesis after the electroweak phase transition. The strongest bound comes from the process $W + W \rightarrow e + e$ (as shown in figure 1). This bound of about 20 keV does not depend on the details of the models and may not be avoided even if the particles are not stable.

Acknowledgement I would like to thank Professor E.A. Paschos, Univ Dortmund, Germany for hospitality, where part of this work has been done and Alexander von Humboldt Foundation for a fellowship.

References

- [1] E.W. Kolb and M.S. Turner, *The Early Universe* (Addison-Wesley, Reading, MA, 1989).
- [2] G. 't Hooft, Phys. Rev. Lett. **37** (1976) 8.
- [3] V.A. Kuzmin, V.A Rubakov and M.E. Shaposhnikov, Phys. Lett. **B 155** (1985) 36.
- [4] D. Brahm, in Proc. XXVI Int. Conf. High Energy Physics, Dallas, Texas, August 1992; M.E. Shaposhnikov, Nucl. Phys. **B 287** (1987) 757; **B 299** (1988) 797; V.A. Rubakov and M.E. Shaposhnikov, report no. hep-ph/9603208 - to appear in Uspekhi (Usp. Fiz. Nauk 166 (May 1996) No 5).
- [5] M.E. Shaposhnikov, Nucl. Phys. **B 287**, 757 (1987); **B 299** (1988) 797; N. Turok and J. Zadrozny, Phys. Rev. Lett. **65** (1990) 2331; A. Kazarian, S. Kuzmin and M.E. Shaposhnikov, Phys. Lett. **B 276** (1992) 131.
- [6] L. McLerran, M.E. Shaposhnikov, N. Turok and M. Voloshin, Phys. Lett. **B 256** (1991) 451;
- [7] A.I. Bochkaev, S.V. Kuzmin and M.E. Shaposhnikov, Phys. Lett. **244 B** (1990) 275; M. Dine, P. Huet and R. Singleton Jr., Nucl. Phys. **B 375** (1992) 625; M.E. Shaposhnikov, Phys. Lett. **316 B** (1993) 112.
- [8] M. Fukugita and T. Yanagida, Phys. Lett. **B 174** (1986) 45; P. Langacker, R.D. Peccei and T. Yanagida, Mod. Phys. Lett. **A 1** (1986) 541; M.A. Luty, Phys. Rev. **D 45** (1992) 445; H. Murayama, H. Suzuki, T. Yanagida and J. Yokoyama, Phys. Rev. Lett. **70** (1993) 1912; A. Acker, H. Kikuchi, E. Ma and U. Sarkar, Phys. Rev. **D 48** (1993) 5006; P.J. O'Donnell and U. Sarkar, Phys. Rev. **D 49** (1994) 2118; H. Murayama,

- H. Suzuki, T. Yanagida and J. Yokoyama, Phys. Rev. Lett. **70** (1993) 1912; M. Flanz, E.A. Paschos and U. Sarkar, Phys. Lett **B 345** (1995) 248; L. Covi, E. Roulet and F. Vissani, SISSA report hep-ph/9605319.
- [9] M. Fukugita and T. Yanagida, Phys. Rev. **D 42** (1990) 1285; S.M. Barr and A.E. Nelson, Phys. Lett. **B 246** (1991) 141; J.A. Harvey and M.S. Turner, Phys. Rev. **D 42** (1990) 3344.
- [10] W. Fischler, G.F. Giudice, R.G. Leigh and S. Paban, Phys. Lett. **258 B** (1991) 45; W. Buchmüller and T. Yanagida, Phys. Lett. **302 B** (1993) 240.
- [11] M. Gell-Mann, P.Ramond and R.Slansky, in *Supergravity*, Proceedings of the Workshop, Stony Brook, New York, 1979, edited by P. van Nieuwenhuizen and D. Freedman (North-Holland, Amsterdam, 1979); T. Yanagida, in *Proc of the Workshop on Unified Theories and Baryon Number in the Universe*, Tsukuba, Japan, 1979, edited by A. Sawada and A. Sugamoto (KEK Report No. 79-18, Tsukuba, 1979).
- [12] J.C. Pati and A. Salam, Phys. Rev. **D10** (1974) 275; R.N. Mohapatra and J.C. Pati, *ibid.* **D11** (1975) 566; R.N. Mohapatra and G. Senjanović, Phys. Rev. Lett. **44** (1980) 912; R.E. Marshak and R.N. Mohapatra, *ibid.* **44** (1980) 1316; J.C. Pati, A. Salam and U. Sarkar, Phys. Lett **133 B** (1983) 330.
- [13] S. Nandi and U. Sarkar, Phys. Rev. Lett. **56** (1986) 564; R.B. Mann and U. Sarkar, Int. Jour. Mod. Phys. **A 3** (1988) 2165; A.S. Joshipura and U. Sarkar, Phys. Rev. Lett. **57** (1986) 33; A. Masiero, D.V. Nanopoulos and A.I. Sanda, Phys. Rev. Lett. **57** (1986) 663.
- [14] A. Zee, Phys. Lett. **93 B** (1980) 389; L. Wolfenstein, Nucl. Phys. **B175** (1980) 93.

- [15] S. Nussinov, Phys. Lett. **165 B** (1985) 55; E. Farhi and L. Susskind, Phys. Rev. **D20** (1979) 3404; S. Dimopoulos, Nucl. Phys. **B 168** (1980) 69.
- [16] A. Masiero and R.N. Mohapatra, Phys. Lett. **103 B** (1981) 343.

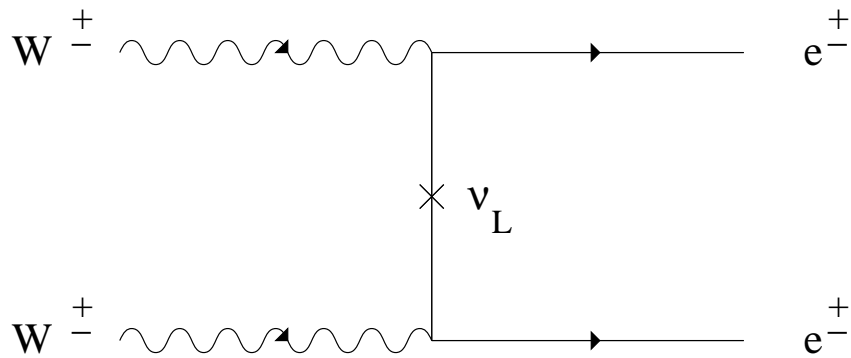

Figure 1: Lepton number violating processes $W^\pm + W^\pm \rightarrow e^\pm + e^\pm$ mediated by the left handed Majorana neutrinos.