

# ISOTROPIC BACKGROUND COSMIC X-RAYS IN THE ENERGY RANGE 50–290 KeV

BY U. R. RAO, E. V. CHITNIS AND A. S. PRAKASARAO

(Physical Research Laboratory, Ahmedabad, India)

Received October 17, 1967

(Communicated by Dr. K. R. Ramanathan, F.A.Sc.)

## ABSTRACT

The observations of omnidirectional X-ray flux at the top of the atmosphere have been extended upto 200 KeV using a balloon-borne NaI (Tl) scintillator detector at Hyderabad, India. The omnidirectional flux at 60 KeV is found to be  $0.0066 \pm 0.0014$  photons/cm.<sup>2</sup> sec. ster. KeV. The X-ray flux in the energy range 50–290 KeV can be adequately represented by the spectrum  $KE^{-2.2 \pm 0.4}$ . New upper limits to the hard X-ray flux from the quiet sun have also been obtained from the same measurement.

## INTRODUCTION

It is now well known (Hayakawa *et al.*, 1966) that there exists an isotropic X-ray component on the top of the atmosphere which is of metagalactic origin. It has been suggested that these X-rays of low energy are either due to the superposition of a number of small X-ray sources in other galaxies or due to the inverse Compton effect produced during the collision of relativistic intergalactic electrons with photons. In spite of the theoretical difficulties encountered with either of the explanations, it is of importance to experimentally determine the flux and the energy spectrum of the isotropic X-ray background. The omnidirectional X-ray flux has been detected by balloon-borne scintillator telescopes (Brini *et al.*, 1965; Bleeker *et al.*, 1967) as well as by rocket and satellite experiments (Metzger *et al.*, 1964; Mutsuoka *et al.*, 1967). The balloon measurements are always contaminated by the background, cosmic ray effects in the atmosphere. In order to minimise the atmospheric background, it is of great advantage to perform the experiment near the geomagnetic equator, where the cosmic ray background is minimum.

To this end a balloon-borne X-ray detector was launched from Hyderabad, India (17° 25' N, 78° 35' E) on April 21, 1967. In this paper,

we present the data from this flight and compare our results with the results obtained by other investigators. Figure 1 shows the schematic diagram of the X-ray detector that was flown in the balloon. The detector consists of a NaI (Tl) crystal of diameter about 6" which was viewed by a 5" DuMont Photomultiplier 6364. The field of view of the detector was defined by a set of mechanical collimators made of copper plates of thickness  $\frac{1}{8}$ ". The crystal was further surrounded by graded shielding consisting of copper and aluminium to minimise the background. The semi-angle of opening of the collimators was about  $10^\circ$  in both directions. The balloon reached a float altitude of about 7 gm./cm.<sup>2</sup>

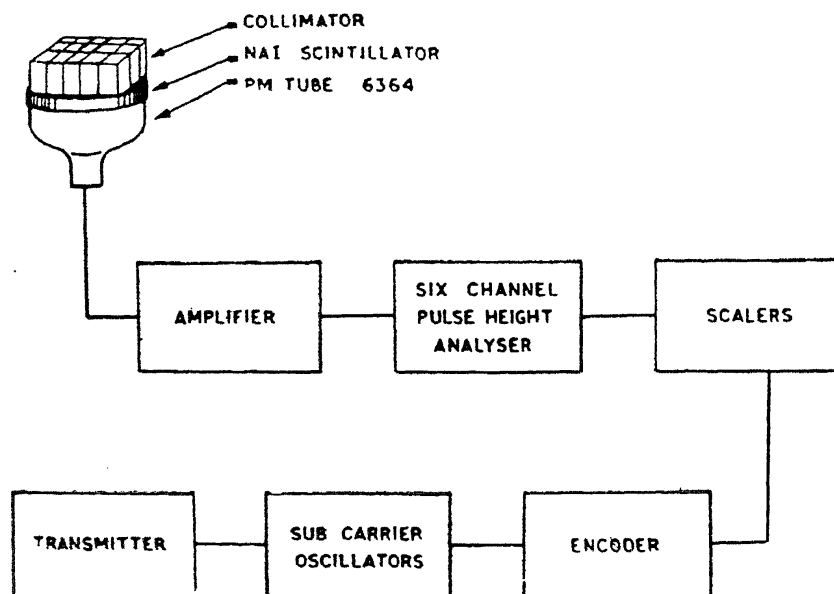

FIG. 1. The block diagram of the balloon-borne X-ray detector.

The detector energy resolution was found to be 21% at 660 KeV and 40% at 64 KeV (FWHM). In the flight configuration, the pulses from the photomultiplier were subjected to pulse height analysis and the counting rates in five contiguous channels in the energy range 50–290 KeV and the integral counting rate for energy losses above 290 KeV were telemetered to the ground. The ground station consisted of a compatible FM/FM receiver, subcarrier filters and a high speed chart recorder. The detector was checked thoroughly before the flight for the linearity with respect to energy.

#### FLUX OF ISOTROPIC X-RAYS

Figure 2 represents the X-ray counting rates *versus* time at and near the ceiling altitude for four different energy intervals between 50–290 KeV.

It may be seen that the X-ray counting rate after the Pfofzer maximum steadily decreases with altitude till it reaches about 12 mb. and then shows an increase beyond that altitude. The increase represents the contribution due to the isotropic X-rays of galactic origin. This flux has to be corrected

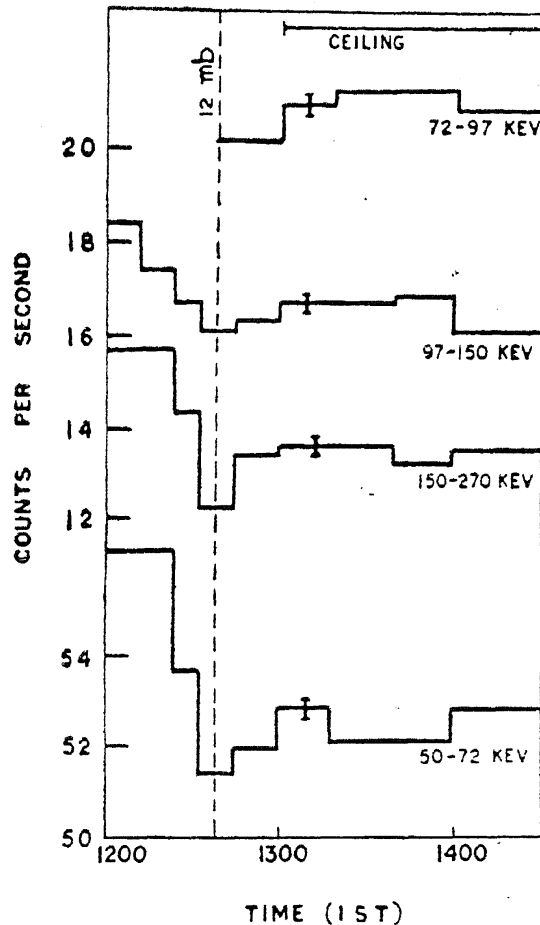

FIG. 2. The counting rates of X-rays of different energies as a function of time near the ceiling altitude.

for the atmospheric absorption to obtain the flux at the top of the atmosphere. In Fig. 3 the omnidirectional cosmic X-ray flux observed at the top of the atmosphere is plotted as a function of energy. Corrections for the residual X-rays that can penetrate to 12 mb. has also been taken into account in the derivation of omnidirectional flux. The results obtained by the NRL, ASE group and the Nagoya group at low energies and the results obtained by Bleeker *et al.* (1966) and Hudson *et al.* (1966) at energies above 25 KeV by balloon experiments are also plotted in the same figure. It may be observed that our results are in substantial agreement with the results obtained by other workers. The X-ray flux at 60 KeV is found to be  $0.0066 \pm 0.0014$  photons/cm.<sup>2</sup> sec. ster. KeV. We wish to point out

that the fluxes at high energies are upper limits and the actual fluxes at 100 KeV and beyond may be actually lower if the efficiency of the collimator is taken into account. The results can be adequately represented by a power law of the form  $KE^{-2.2 \pm 0.4}$ . The X-ray flux expected from thermal radiation spectrum  $\exp. (E/KT) E^{-1} dE$  (Free-Free transitions) from a thin hot plasma at  $2 \times 10^8$  K is also plotted in Fig. 3. Even though the flux below 20 KeV agrees well with the above calculation, the disagreement at higher energies with the observed results shows that the omnidirectional cosmic X-rays cannot be adequately explained by thermal processes.

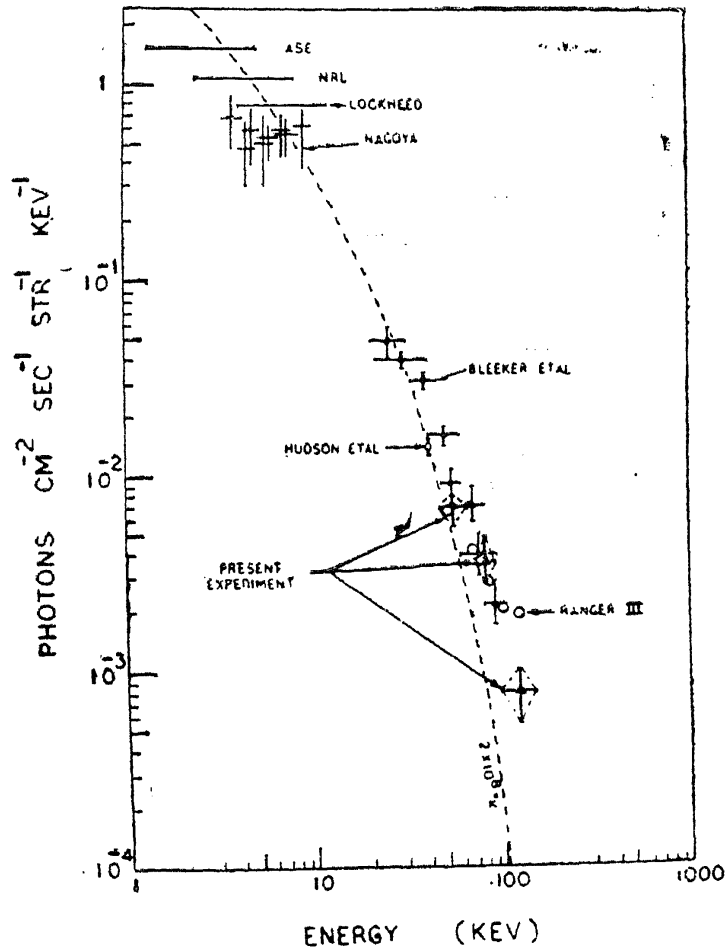

FIG. 3. The omnidirectional X-ray flux at the top of the atmosphere.

The spectrum of the background component given by Bleeker *et al.* (1967) and Rothenflug *et al.* (1965) agrees very closely with the exponent of the spectrum derived from our data. The spectrum of isotropic X-rays at energies below 10 KeV as quoted by Mitsuoka *et al.* (1967) however is found to be of the form  $KE^{-1.7 \pm 0.4}$  indicating a hardening of the spectrum at lower energies. The change of slope and softening of the spectrum of isotropic X-rays at energies above 10 KeV may be due to absorption in intergalactic matter.

## UPPER LIMIT FOR HARD X-RAYS FROM SUN

The SUN (Declination  $11^{\circ}43'$ ) crossed the balloon meridian at about noon local time. More than 3 hours of data is available when the solar zenith angle was less than  $25^{\circ}$ . Any contribution from the sun, if it were more than thrice the standard deviation level of the background rate obtained during the period when the sun is making a large zenith angle with respect to the instrument, would have been detected by our instrument with a certainty better than 99%. Since no such flux was observed, we may consider the  $3\sigma$ -level as the upper limit for the solar contribution of hard X-rays. Since the level of solar activity on April 21, 1967 was quite low, our limit essentially corresponds to the limit for quiet sun.

Following Edwards and McCracken (1967), we may represent the differential pulse height spectrum  $S(H) dH$  (the counting rate in the pulse height interval  $dH$  at  $H$ ) by

$$S(H) = \frac{\bar{A}(\theta)}{\sqrt{2\pi}} \int_{E_0}^{\infty} \frac{\epsilon(E) j(E)}{\sigma(E)} \exp. - \left\{ \mu(E) x \sec. \theta + \mu'(E) x' \sec. \theta + \frac{(H-E)^2}{2\sigma(E)^2} \right\} dE.$$

where  $j(E)$  is the Photon energy spectrum of a discrete source,  $\bar{A}(\theta)$  is the projected area of the telescope at zenith angle  $\theta$  of the sun,  $\epsilon(E)$  is the efficiency of the detector.  $\mu(E)$  and  $\mu'(E)$  are the narrow beam attenuation coefficients of air and crystal mounting respectively and  $\sigma(E)$  specifies the energy resolution of the detector.

Taking  $\epsilon(E) = 1$ ,  $x = 7.2 \text{ gm./cm.}^2$  of air,  $x' = 0.0849 \text{ gm./cm.}^2$  of aluminium and  $\sigma(E) = \sqrt{E} \text{ (KeV)}$  the upper limits to monoenergetic solar X-rays of different energies have been calculated. Figure 4 shows the results obtained for the flux of hard X-rays from the sun. The results obtained by Frost and Peterson (Lindsay, 1963), Frost *et al.* (1966) and by Edwards and McCracken (1967) are also plotted in the same figure. It may be observed that the upper limit for the hard X-rays from the quiet sun obtained by us is much lower than that obtained by other workers.

Extrapolation of our results to higher energies show that the integral flux of X-rays from the sun is about  $1.5 \times 10^{-2}$  photon/cm.<sup>2</sup> sec. above 50 KeV. This result is at least one order of magnitude below the results obtained during the solar maximum by Chubb *et al.* (1966) indicating that

the flux of hard X-rays from the quiet sun varies by at least one order of magnitude over the solar cycle. Similar conclusion has been drawn by Edwards and McCracken (1967).

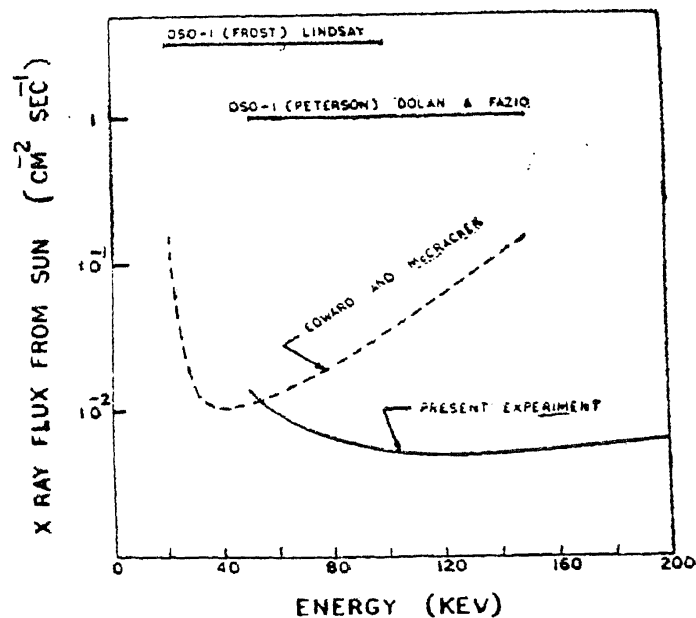

FIG. 4. The upper limit for the emission of hard X-rays from the sun.

### CONCLUSIONS

In conclusion we observe that the flux of omnidirectional X-rays of cosmic origin at 60 KeV is  $0.0066 \pm 0.0014$  photons/cm.<sup>2</sup> sec. ster. KeV. The measured fluxes at different energies are consistent with a spectrum of the type  $KE^{-2.2 \pm 0.4}$ , which is considerably steeper than the spectrum of cosmic X-rays of energy below 10 KeV.

Upper limit for the hard X-ray emission from the quiet sun has been obtained. The limits are considerably lower than the upper limits quoted so far. The results indicate that the emission of hard X-rays (20 KeV) from the quiet sun may vary by one order of magnitude over the solar cycle.

### ACKNOWLEDGEMENT

The authors wish to thank Drs. B. V. Sreekantan and K. Appa Rao of Tata Institute of Fundamental Research, Bombay, India, and Dr. R. P. Kane of Physical Research Laboratory, Ahmedabad, India, for helpful discussions. The help of Drs. G. S. Gokhale and R. T. Redkar and their group at TIFR, Bombay, India, in launching the balloon is gratefully acknowledged. The research was supported by the funds from the Department of Atomic Energy, Government of India.

## REFERENCES

1. Bleeker, J. A. M., Burger, J. J., Deerenberg, A. J. M., Swanenburg, B. N. and Tanaka, Y. "Balloon observation of the X-ray sources in the cygnus," *Ap. J.*, 1967, **147**, 391–94.
2. Brini, D., Ciriegi, U., Fulgni, F., Gandolfi, A. and Moretti, E. "Evaluation of the X-ray primary omnidirectional flux from measurements at balloon altitudes," *Nuovo Cimento*, 1965, **38**, 4710–20.
3. Chubb, T. A., Kreplin, R. W. and Friedman, H. "Observations of hard X-ray emission from solar flares," *J. Geophys. Research*, 1966, **71**, 3611–22.
4. Edwards, P. J. and McCracken, K. G. "Upper limits to the hard X-ray flux from the quiet sun and Jupiter," *Ibid.*, 1967, **72**, 1809–12.
5. Frost, K. J., Rothe, E. D. and Peterson, L. E. "A search for the quiet-time solar gamma rays from balloon altitudes," *Ibid.*, 1966, **71**, 4079–089.
6. Hayakawa, S., Mutsuoka, M. and Sugimoto, D. "Galactic X-rays," *Space. Sc. Rev.*, 1966, **5**, 109–63.
7. Hudson, H. S., Primbsch, J. H. and Anderson, K. A. "Observations of the isotropic component of cosmic X-rays at balloon altitude," *J. Geophys. Research.*, 1966, **71**, 5665–68.
8. Lindsay, J. G. "Scientific results of the first orbiting solar observatory", *Trans. Am. Geophys. Union*, 1963, **44**, 722–25.
9. Mutsuoka, M., Oda, M., Ogwara, Y., Hayakawa, S. and Kato, T. "Observation of the background component of cosmic X-rays," Presented at the 10th Intl. Conf. on Cosmic Ray, Calgary (1967).
10. Metzger, A. E., Anderson, E. C., Van Dilla, M. A. Arnold, J. R. Jr. "Detection of an interstellar flux of gamma-rays," *Nature*, 1964, **204**, 766–67.
11. Rothenflug, R., Rocchia, R. and Koch, L. "The energy spectrum of primary galactic X-rays between 20 and 50 KeV," *Proc. 9th Intl. Conf. on Cosmic Rays*, 1965, pp. 446–48.