

SOLUTION PHASE SYNTHESIS OF ALAMETHICIN I

R. NAGARAJ and P. BALARAM*

Molecular Biophysics Unit, Indian Institute of Science, Bangalore-560012, India

Abstract—The total synthesis of alamethicin I by solution phase methods is reported.

The microbial peptide alamethicin has aroused considerable interest due to its membrane-modifying properties. The polypeptide is known to lyse cells, cause fusion of liposomes¹ and has been used to study sidedness of natural membranes.³⁻⁵ A particularly interesting property of alamethicin is its ability to induce excitability in artificial lipid bilayer systems.⁶ While extensive studies on the transport properties of alamethicin channels in membranes have been reported,⁷⁻⁹ there has been some confusion regarding the primary structure of alamethicin.¹⁰⁻¹² The original cyclic structure postulated by Payne *et al.*¹⁰ was found incompatible with 270 MHz ¹H NMR data.¹¹ Martin and Williams then proposed an acyclic structure¹¹ and this sequence was further modified by Pandey *et al.*¹² The studies on alamethicin have been hampered by the heterogenous nature of the material from natural sources. In a recent report Marshall and Balasubramanian¹³ have shown that the alamethicin used for biological studies has eight components. However they have identified the major component as having a structure similar to the one proposed by Pandey *et al.* (Fig. 1). Alamethicin I is characterised by the presence of a large number of sterically hindered¹⁴ α -aminoisobutyric acid (Aib) residues and an alcohol derived from L-Phe at the C-terminal. In order to probe the secondary structure of alamethicin and thereby develop models for its membrane activity, a program was initiated to study synthetic alamethicin fragments and model Aib peptides by spectroscopy¹⁵⁻¹⁸ and X-ray crystallography.¹⁹⁻²² In this paper we report the total synthesis of alamethicin I by solution phase methods.

Outline of synthetic scheme

The scheme for the synthesis of the amino terminal hexapeptide is shown in Fig. 2. The tripeptides Z-Aib-Pro-Aib-OH and Boc-Ala-Aib-Ala-OMe were synthesised stepwise. The hexapeptide was obtained by coupling Z-Aib-Pro-Aib-OH to H₂N-Ala-Aib-Ala-OMe in DMF with DCC and HOBT. The 7-13 fragment

was synthesised from Boc-Gln-Aib-OBzl, Boc-Val-Aib-OMe and Boc-Gly-Leu-Aib-OMe as shown in Fig. 3. In the synthesis of Boc-Gln-Aib-OBzl, HOBT was added to prevent dehydration of the side chain amide of Gln, during DCC activation.²³ Hydrogenolysis of the dipeptide was achieved by catalytic transfer hydrogenation using palladium black and cyclohexene.²⁴ The 14-17 tetrapeptide was synthesised by coupling Boc-Pro to H₂N-Val-Aib-Aib-OMe as shown in Fig. 4. Boc-Val-Aib-OH was coupled to Aib-OMe in DMF with DCC and HOBT. The coupling did not proceed to give the tripeptide when only DCC was used. Instead the corresponding oxazolone was obtained, which was characterised by the IR band²⁵ at 1820 cm⁻¹. Boc-y-benzyl Glu-Gln was synthesised by the active ester method using HOSU and coupled to Phol to give the 17-20 fragment of alamethicin (Fig. 5). The major fragments were coupled as shown in Fig. 6. Throughout the synthesis amino acid and peptide free bases were used instead of the acid salts accompanied by *in situ* neutralisation. Schemes involving dipeptide fragments of Aib were not used as their deprotection lead to the formation of corresponding diketo-piperazines.²⁶ An important observation during the course of the synthesis was the detection of extensive racemisation by NMR in sequences R-Aib-X-COOH (X is an optically active amino acid) when only DCC was used as the coupling reagent.²⁷ However, optically pure peptides were obtained when HOBT was used as an additive.

Characterisation of peptide fragments

The various peptide fragments obtained during the course of alamethicin synthesis were characterised by elemental analysis and in the case of larger fragments by amino acid analysis and high field ¹H and ¹³C NMR. The C, H, N analysis obtained for the various fragments are summarised in Table 1. The largest fragment for which elemental analysis was obtained was the 1-13 fragment. In every case, the results were satisfactory. The amino acid analysis data on the larger fragments are summarised in Table 2. Satisfactory results for all the amino acids were obtained. Ratios for Aib could not be obtained due to low colour value of sterically hindered Aib. The 270 MHz ¹H NMR¹⁸ spectra were fully consistent with the structures and yielded satisfactory integrals for the various groups of hydrogens. Detailed conformational analysis of the 1-6 and 7-13 fragments

*Address for correspondence.

†Aib, α -aminoisobutyric acid; Ac, acetyl; Boc, t-butyloxy-carbonyl; DCC, N,N-dicyclohexylcarbodiimide; DMF, dimethyl-formamide; HOBT, 1-hydroxybenzotriazole; HOSU, N-hydroxy-succinimide; OBzl, benzyl ester; OMe, methyl ester, Phol(phenylalaninol); POE, polyoxyethylene.

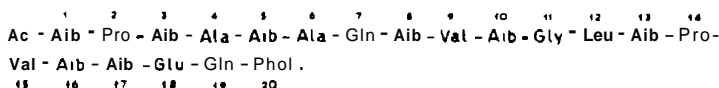

Fig. 1. Sequence of alamethicin I proposed by Pandey *et al.*¹²

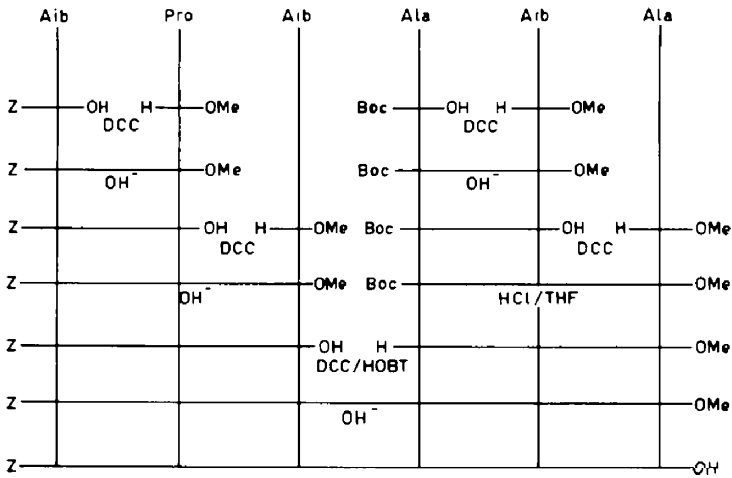

Fig. 2. Scheme for the synthesis of 1-6 fragment.

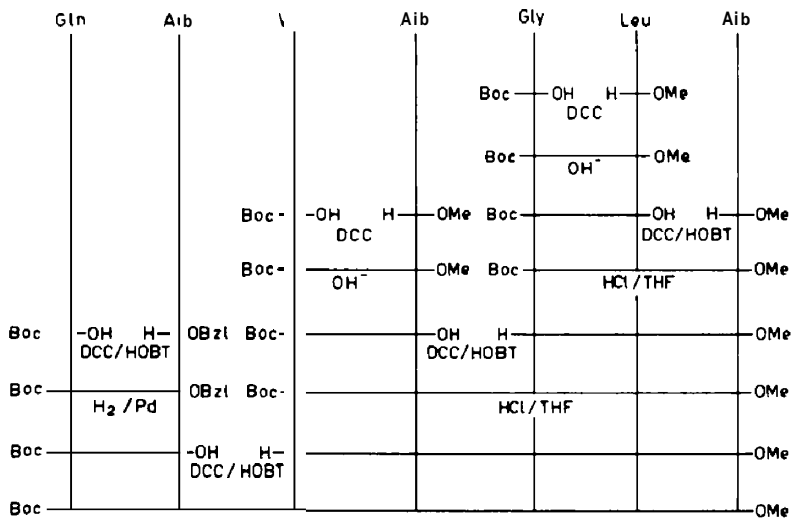

Fig. 3. Scheme for the synthesis of 7-13 fragment.

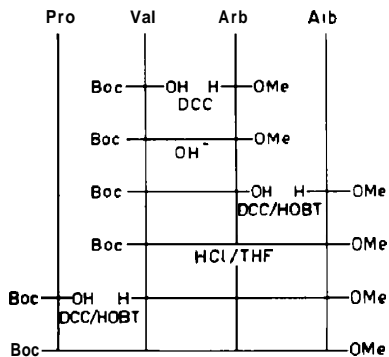

Fig. 4. Scheme for the synthesis of 14-17 fragment.

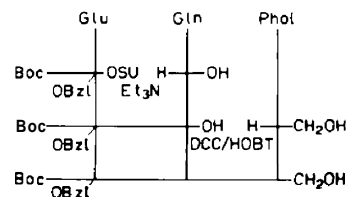

Fig. 5. Scheme for the synthesis of 18-20 fragment.

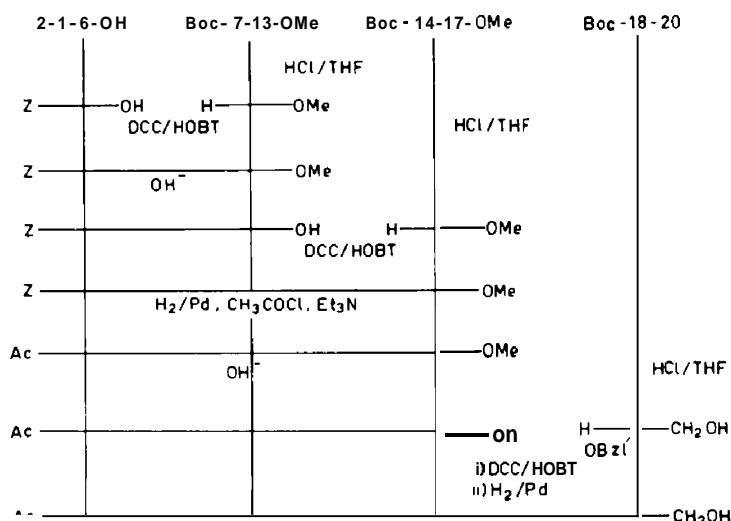

Fig. 6. Scheme for the condensation of 1-6, 7-13, 14-17 and 18-20 fragments.

have been completed by **NMR**. 67.89MHz ^{13}C spectra" of the alamethicin fragments also supported the assigned structures. While ^1H and ^{13}C **NMR** have been extensively used in organic chemistry, their routine application to the monitoring of peptide synthesis has been a relatively recent phenomenon. This has in part been aided by the availability of high field Fourier Transform **NMR** spectrometers that afford both the sensitivity and chemical shift resolution that are necessary in studies of oligo peptides. Examples stressing application of **NMR** to the monitoring of peptide synthesis^{28,29} have appeared in the literature.

Characterisation of synthetic alamethicin

Synthetic alamethicin was characterised by amino acid analysis and comparison of its tlc, CD and UV spectra with natural alamethicin. The synthetic and natural peptides were also compared for their ability to render liposomes permeable to cations. In chloroform/methanol/water 65:24:4, synthetic alamethicin showed a spot at $R_f = 0.56$ (silica gel) and a faint spot at $R_f = 0.60$. Natural alamethicin had a R_f of

0.56 in this solvent system. In n-butanol/acetic acid/water (4:1:1), synthetic alamethicin showed a spot at $R_f = 0.44$ and a faint spot at $R_f = 0.80$ compared to a $R_f = 0.48$ of natural alamethicin. The spots were visualised by staining with iodine. The amino acid analysis for synthetic alamethicin is summarised in Table 2. Satisfactory results for all the amino acids were obtained. As in the case of fragments, ratios for Aib could not be obtained due to low colour value of Aib. Hence, only relative values of Aib in the 1-17 fragment and alamethicin normalised with respect to Gly is reported. Phol could not be detected under the conditions used for amino acid analysis. In fact Gisin *et al.*³² have used a buffer of pH 10 to identify Phol. However the presence of Phol is easily identified from UV (Fig. 7) and **NMR**. The CD spectra of synthetic and natural alamethicin³⁰ are shown in Fig. 8. Small differences in the spectra of the natural and synthetic peptides could possibly arise from the heterogeneity of the natural material, which is contaminated by closely related polypeptides. However, the synthetic and natural peptides compare reasonably well. The cation translocating

Table I. Elemental analysis of the fragments of alamethicin I

Peptide	Calculated			Found		
	C%	H%	N%	C%	H%	N%
Z-Aib-Pro-Aib-OMe <u>3</u>	60.96	7.16	9.70	61.32	7.29	9.41
Boc-Ala-Aib-Ala-OMe <u>7</u>	53.46	8.30	11.69	52.97	8.50	11.46
Z-Aib-Pro-Aib-Ala-Aib-Ala-OH <u>9</u>	57.47	7.17	13.00	57.31	7.60	12.52
Boc-Gln-Aib-OBz1 <u>10</u>	58.66	7.63	10.26	58.53	7.87	10.52
Boc-Gly-Leu-Aib-OMe <u>16</u>	56.78	8.64	12.25	56.96	8.49	11.98
Boc-Val-Aib-Gly-Leu-Aib-OMe <u>17</u>	55.79	8.58	10.85	55.44	8.78	11.19
Boc-Gln-Aib-Val-Aib-Gly-Leu-Aib-OMe <u>18</u>	56.23	8.39	14.57	55.78	8.74	14.67
Boc-Val-Aib-Aib-OMe <u>19</u>	56.84	8.79	10.47	57.20	0.40	10.57
Boc-T-benzyl Glu-Gln-Phol <u>22</u>	62.19	7.07	9.36	62.59	7.51	9.51
Z-(1-13)-OMe <u>23</u>	56.70	7.62	14.94	56.28	7.99	14.61

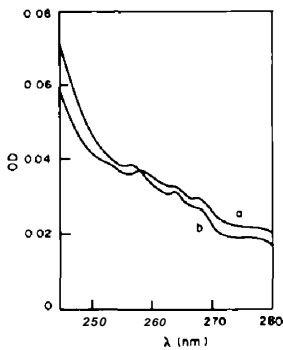

Fig. 7. UV spectra of (a) Natural alamethicin (b) Synthetic alamethicin in methanol at 20°, 1 mg/ml.

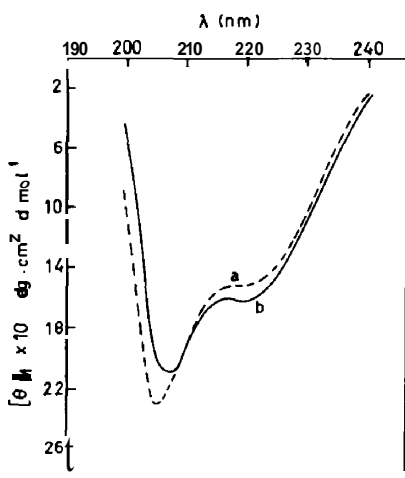

Fig. 8. CD spectra of (a) Synthetic alamethicin (b) Natural alamethicin; in trifluoroethanol at 20°, 0.2 mM.

effects of synthetic and natural alamethicin³¹ in unilamellar egg lecithin vesicles, monitored by time dependent changes in Ca^{2+} -chlorotetracycline fluorescence is shown in Fig. 9. A good correlation is clearly seen between the synthetic and natural peptides. While a well resolved ^1H NMR spectrum of alamethicin could **not** be obtained even at 270 MHz, peaks corresponding to aromatic protons of Phol -76 and acetyl protons -26 were clearly discernable. Earlier reports describing the NMR of natural alamethicin³² used the convolution difference technique to enhance resolution.

A very useful feature of Aib containing peptides is their relatively restricted range of backbone conformations. The reduction in conformational freedom imposed by the presence of Aib residues facilitates the ready crystallisation of many peptides. As a consequence even large fragments could be purified by crystallisation. The availability of single crystals provides a method for the determination of molecular weights by X-ray diffraction if accurate cell parameters and crystal densities can be obtained. The crystal data for some synthetic fragments of alamethicin are listed in Table 3. For the amino terminal 1-6 and 1-13 fragments, molecular weights obtained were 649 and 1412.5. While the agreement is good for the 1-6 fragment with the calculated mol wt of 660, the slightly higher mol wt of the 1-13 fragment obtained from the crystal as compared to the calculated mol wt of 1312 may be due to the cocrystallisation of solvent molecules. The mol wt obtained for synthetic alamethicin was 1852. The calculated value is 1960. The mol wt determined by X-ray crystallography is based on an assumed density of 1.25 for the crystal. Actual density measurements were not carried out as only one or two good single crystals were available. However the expected error is about ± 100 . The X-ray results, together with the spectroscopic and amino acid analysis confirm that

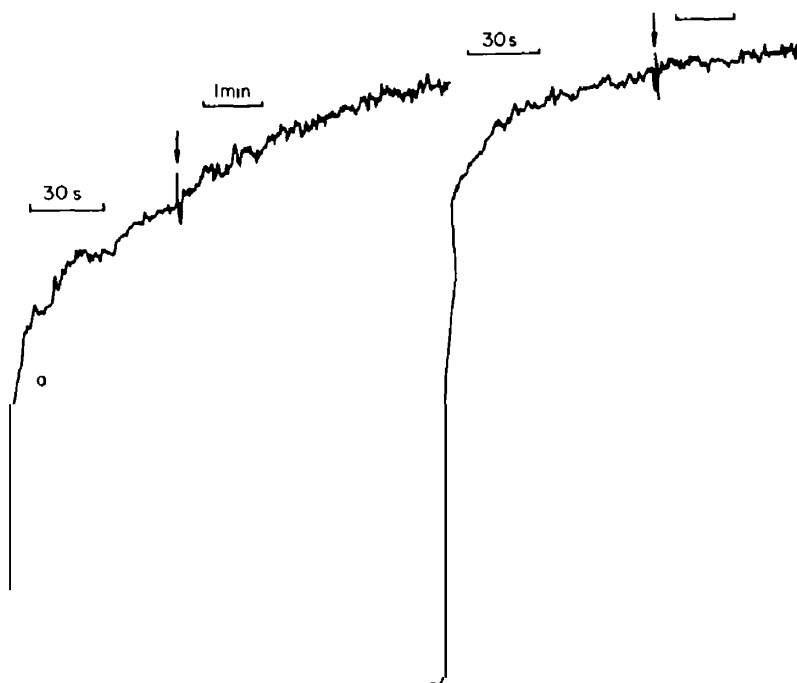

Table 2. Amino acid analysis of the fragments of alamethicin I

Peptide ^a	Ala	Glx	Gly	Leu	Pro	Val	Aib
Boc-Gln-Aib-Val-Aib-Gly-Leu-Aib-OMe <u>18</u>	-	1.00 (1.00)	1.00 (1.00)	1.17 (1.00)	-	0.91 (1.00)	-
Z-Aib-Pro-Aib-Ala-Aib-Ala-Gln-Aib-Val-Aib-Gly-Leu-Aib-OMe <u>23</u>	2.25 (2.00)	0.86 (1.00)	1.00 (1.00)	0.07 (1.00)	1.11 (1.00)	0.82 (1.00)	2.20 ^b
Z-Aib-Pro-Aib-Ala-Aib-Ala-Gln-Aib-Val-Aib-Gly-Leu-Aib-Pro-Val-Aib-Aib-OMe <u>24</u>	2.18 (2.00)	0.92 (1.00)	1.00 (1.00)	0.92 (1.00)	2.20 (2.00)	2.26 (2.00)	1.07 ^c
Synthetic alamethicin <u>27</u>	1.82 (2.00)	2.86 (3.00)	1.00 (1.00)	0.92 (1.00)	1.60 (2.00)	1.83 (2.00)	-

^a Numbers in brackets are theoretical values.

^b Aib value is the ratio Aib (1-13 fragment 23)/Aib (7-13 fragment 18) normalised with respect to Gly.

^c Aib value is the ratio Aib (1-17 fragment 24)/Aib (Synthetic alamethicin 27) normalised with respect to Gly.

the synthetic product corresponds to alamethicin I sequence.

The synthesis of alamethicin reported in this paper differs in several respects from the solid phase synthesis reported by Gisin *et al.*^{32,33} and the synthesis of amino terminal 1-11 peptide by the POE method by Mayr *et al.*³⁴ In the former, a combination of stepwise and fragment couplings was adopted and a large excess of protected amino acid derivatives and peptide fragments was used to ensure complete coupling. Further, extensive

purification of the fragments and the final product by chromatography was necessary. Aib was quantitated by using small amounts of ¹⁴C labelled Aib in the synthesis. The synthesis by Gisin *et al.*^{32,33} although elegant turns out to be fairly expensive, due to the large excess of fragments used and the sophisticated monitoring system. In the synthesis of the 1-11 amino terminal fragment of alamethicin by Mayr *et al.*³⁴ purification of the POE bound peptide esters was easily effected by precipitation. However, as in the case of solid phase synthesis, large

Table 3. Crystal data for the fragments of alamethicin I

Peptide	Molecular weight calculated observed	Density	Space group	Cell parameters
Z-Aib-Pro-Aib-Ala-Aib-Ala-OMe <u>9</u>	660 648	1.20	P2 ₁ 2 ₁ 2 ₁	a = 10.96 Å b = 11.781 Å c = 28.406 Å
Z-Aib-Pro-Aib-Ala-Nb-Ala-OH <u>9</u>	645 670	1.24	P2 ₁ 2 ₁ 2 ₁	a = 9.92 Å b = 16.23 Å c = 22.01 Å
Z-(1-13)-OMe <u>23</u>	1312 1412.4	1.20 ^b	P2 ₁ 2 ₁ 2 ₁	a = 28.08 Å b = 22.14 Å c = 23.82 Å
Synthetic ala-methicin <u>27</u>	1960 1052	1.20 ^b	P2 ₁	a = 7.75 Å b = 18.53 Å c = 35.66 Å β = 93.2°

^a X-ray data for the peptides were provided by Dr.N.Shamala from this laboratory.

^b Assumed density.

excess of amino acid derivatives were used in the synthesis. In the synthetic approaches to alamethicin reported in this paper, good yields were obtained with equimolar amounts of the amino acid derivatives and peptide fragments as compared to the studies of Gisin *et al.*^{32,33} and Mayr *et al.*³⁴ Extensive use of chromatographic methods for the purification of the peptides was not necessary as pure peptides could be obtained by routine crystallisations. An important aspect of the present synthesis is that the fragments could be used for further conformational studies by spectroscopic and crystallographic methods.

EXPERIMENTAL

Mps reported are uncorrected. Optical rotations were recorded in a Jobin Yvon polarimeter at 589 nm. CD spectra were recorded using a Jasco J-20 spectropolarimeter. Micro analysis and amino acid analysis were obtained through the courtesy of Department of Organic Chemistry, Indian Institute of Science, Bangalore, India and Dr. G. M. Anantharamiah of Ohio State University, Columbus, USA, respectively. Crystal parameters were measured in this laboratory by Dr. N. Shamala, Natural alamethicin was obtained as a gift from Dr. G. E. Grady, The Upjohn Company, Michigan, USA.

Boc and benzyloxycarbonyl amino acids were prepared by conventional procedures. Amino acid methyl esters were prepared as follows: The methyl ester hydrochloride³⁵ was dissolved in sat Na₂CO₃ aq and extracted with CHCl₃. On drying and evaporating the organic layer, the free base ester was obtained as an oil. AU peptides were checked for homogeneity by tlc on silica gel using 5% and 10% MeOH/CHCl₃ for amino protected peptide esters and n-BuOH/AcOH/water 4:1:1 for amino protected peptide acids. The peptide free base esters were checked for purity by tlc on silica gel by iodine and ninhydrin visualisation and used without further purification. The protected peptides were also checked by 270 MHz ¹H and 67.89 ¹³C NMR.

Synthesis of Z-Aib-Pro-Aib-Ala-Aib-Ala-OH

Z-Aib-Pro-Ome 1. Z-Aib (2.6 g, 10 mmol) was dissolved in CH₂Cl₂ (15 ml) and cooled to 0°. Pro-Ome (1.5 g, 10 mmol) was added followed by DCC (2.16 g, 10 mmol). The mixture was stirred at room temp. overnight. The dicyclohexylurea (DCU) was filtered off and the organic layer washed with 1N HCl, H₂O, 1M NaHCO₃ and dried over Na₂SO₄. The organic layer was evaporated to leave an oily residue. The oil solidified on keeping in the cold for several days, yield=2.9 g (80%); m.p.=85-88°; Lit=Oil³⁶; [α]_D²⁵=-87.5° (c=0.2 in MeOH).

Z-Aib-Pro-OH 2. The ester 2 (2.9 g, 8 mmol) was dissolved in MeOH (5 ml) and 2N NaOH (8 ml) added. After 12 hr at room temp., H₂O (25 ml) was added and the aqueous layer extracted with EtOAc (4 x 25 ml). The aqueous layer was acidified with 1N HCl and extracted with EtOAc 4 x 25 ml. On drying and evaporating the organic layer, the dipeptide was obtained as an oil, yield=2.1 g (75%).

Z-Aib-Pro-Aib-Ome 3. The tripeptide was obtained by coupling 2 (2.1 g, 7 mmol) to Aib-Ome (0.8 g, 7 mmol) in CH₂Cl₂ as in the case of 1. Evaporation of CH₂Cl₂ yielded an oily residue which solidified on trituration with petroleum ether. The compound was recrystallised from MeOH-ether, yield=2.1 g (75%); m.p.=160° [α]_D²⁵=-12.5° (c=0.2 in MeOH).

Z-Aib-Pro-Aib-OH 4. The ester 3 (2.1 g) was saponified as in the case of 1 to give the tripeptide acid yield = 1.7 g (85%); m.p.=195°; [α]_D²⁵=-12.5° (c=0.2 in MeOH).

Boc-Ala-Aib-Ome 5. The dipeptide was obtained by coupling Boc-Ala (1.52 g, 8 mmol) to Aib-Ome (0.92 g, 8 mmol) as in the case of 1, yield=1.8 g (80%); m.p.=82-84°; [α]_D²⁵=-30.2° (c=0.2 in MeOH).

Boc-Ala-Aib-OH 6. The ester 5 (1.8 g) was saponified with 2N NaOH-MeOH as in the case of 2 to give the acid, yield=1.6 g (90%); m.p.=170°; [α]_D²⁵=-47.5° (c=0.2 in MeOH).

Boc-Ala-Aib-Ala-Ome 7. The acid 6 (1.6 g, 6 mmol) was coupled to Ala-Ome (0.620 g, 6 mmol) as in the case of 3, yield

= 1.51 g (70%); m.p.=158°; [α]_D²⁵=-2.5° (c=0.2 in MeOH).

Z-Aib-Pro-Aib-Ala-Aib-Ala-Ome 8. The tripeptide 7 (1.1 g, 3 mmol) was dissolved in 2N HCl/THF. After 4 hr, the removal of Boc group was complete. The THF was evaporated, the residue dissolved in H₂O and filtered to remove some undissolved material. The aqueous layer was made alkaline with Na₂CO₃ and extracted with CHCl₃ (3 x 10 ml). On drying and evaporating CHCl₃, H₂N-Ala-Aib-Ala-Ome was obtained as an oil.

The acid 4 (1.0 g, 2.4 mmol) was dissolved in DMF (10 ml) and cooled to 0°. H₂N-Ala-Aib-Ala-Ome (6.00 g, 2.4 mmol) in DMF (5 ml), HOBT (0.325 g, 2.4 mmol) and DCC (0.500 g, 2.4 mmol) were added successively. After stirring at room temp. for 36 hr, the N U was filtered off and the filtrate diluted with EtOAc (25 ml). The organic layer was washed with H₂O, 1N HCl, H₂O, 1M NaHCO₃ and dried over Na₂SO₄. On evaporating EtOAc, an oily residue was obtained, which solidified on trituration with petroleum ether and slight warming, yield=1.0 g (60%); m.p.=88°; [α]_D²⁵=10.0° (c=0.2 in MeOH).

Single crystals were obtained from methyl acetate/ether. The cell parameters obtained from X-ray diffraction are summarised in Table 3.

Z-Aib-Pro-Aib-Ala-Aib-Ala-OH 9. The ester 8 (0.700 g) was saponified as in the case of 2 to give the acid, yield=0.600 g (81%); m.p.=220°; [α]_D²⁵=20.0° (c=0.2 in MeOH). Single crystals were obtained from MeOH/ether. The cell parameters obtained from X-ray diffraction are summarised in Table 3.

Synthesis of Boc-Gln-Aib-Val-Aib-Gly-Leu-Aib-Ome

Boc-Gln-Aib-OBzl 10. Boc-Gln (2.0 g, 8 mmol) was dissolved in DMF (15 ml) and cooled to 0°. Aib-OBzl (1.7 g, 8 mmol), HOBT (1.06 g, 8 mmol), DCC (1.650 g, 8 mmol) were added successively and the mixture stirred at room temp. for 24 hr. The DCU was then filtered off and the filtrate diluted with EtOAc (25 ml). The organic layer was washed with H₂O, 1N HCl, H₂O, 1M NaHCO₃ and dried over Na₂SO₄. On evaporating EtOAc and trituration the residue with petroleum ether, the dipeptide ester was obtained as a solid, yield=2.0 g (63%); m.p.=101°; [α]_D²⁵=22.5° (c=0.2 in MeOH).

Boc-Gln-Aib-OH 11. The dipeptide 10 (2.0 g) was dissolved in EtOH (15 ml). Freshly prepared Pd black (0.100 g), cyclohexene (10 ml) were added and the soln refluxed for 2 hr. The soln was decanted to remove Pd black and evaporated. On trituration the residue with ether, the dipeptide acid was obtained, yield=1.35 g (90%); m.p.=176°; [α]_D²⁵=-27.5° (c=0.2 in MeOH).

Boc-Gly-Leu-Ome 12. Boc-Gly (3.0 g, 17 mmol) was coupled to Leu-Ome (2.5 g, 17 mmol) in CH₂Cl₂ as in the case of 1. The dipeptide ester was obtained as an oil, yield=4.4 g (85%).

Boc-Gly-Leu-OH 13. The ester 12 (4.4 g) was saponified as in the case of 2. On trituration the oily residue with petroleum ether, the dipeptide acid was obtained as a solid, yield=4.0 g (95%); m.p.=133°; [α]_D²⁵=-21.0° (c=0.2 in MeOH).

Boc-Gly-Leu-Aib-Ome 14. The tripeptide was obtained by coupling Boc-Gly-Leu-OH (2.3 g, 8 mmol) to Aib-Ome (1.0 g, 8 mmol) in DMF as in the case of 10, yield=1.6 g (62%); m.p.=112°; [α]_D²⁵=-37.5° (c=0.2 in MeOH).

Boc-Val-Aib-Ome 15. Boc-Val (1.74 g, 8 mmol) was coupled to Aib-Ome (1.0 g, 8 mmol) in CH₂Cl₂ as in the case 1, yield=1.75 g (70%); m.p.=115-118°; [α]_D²⁵=-27.5° (c=0.2 in MeOH).

Boc-Val-Aib-OH 16. The dipeptide ester (1.75 g) was saponified as in the case of 12 to give the dipeptide acid, yield=1.6 g (90%); m.p.=163-165°; [α]_D²⁵=-32.5° (c=0.2 in MeOH).

Boc-Val-Aib-Gly-Leu-Aib-Ome 17. Boc group was removed from 14 (1.54 g) as in the case of 7. H₂N-Gly-Leu-Aib-Ome (1.2 g, 4 mmol) was coupled to Boc-Gln-Aib-OH (1.2 g, 4 mmol) in DMF as in the case of 10, yield=1.5 g (65%); m.p.=154-155°; [α]_D²⁵=-32.5° (c=0.2 in MeOH).

Boc-Gln-Aib-Val-Aib-Gly-Leu-Aib-Ome 18. H₂N-Val-Aib-Gly-Leu-Aib-Ome (obtained as in the case of 7 (0.940 g, 2 mmol)) was coupled to Boc-Gln-Aib-OH (0.660 g, 2 mmol) in DMF, with DCC-HOBT as in the case of 10, yield=1.0 g (55%); m.p.=110-112°; [α]_D²⁵=-20.0° (c=0.15 in MeOH).

Synthesis of Boc-Pro-Val-Aib-Aib-OMe and Boc- γ -benzyl-Glu-Gln-Phol

Boc-Val-Aib-Aib-OMe **19**. Boc-Val-Aib-OH (1.5 g, 5 mmol) was coupled to Aib-OMe (0.650 g, 5 mmol) as in the case of **10** in DMF, yield = 1.2 g (60%); m.p. = 140°; $[\alpha]_D^{25} = -17.5$ ($c = 0.2$ in MeOH).

Boc-Pro-Val-Aib-Aib-OMe **20**. Boc-Pro (0.540 g, 2.5 mmol) was coupled to H₂N-Val-Aib-Aib-OMe (0.700 g, 2.5 mmol) (obtained as in the case of **7**) in DMF with DCC-HOBT. The oily residue obtained after removing EtOAc, solidified after several hr in the cold, yield = 0.6 g (5%); m.p. = 135°; $[\alpha]_D^{25} = -55.0$ " ($c = 0.2$ in MeOH).

Boc- γ -benzyl Glu-Gln **21**. Boc- γ -benzyl-Glu (3.0 g, 9 mmol) was dissolved in EtOAc (20 ml) and cooled to 4°. HOSU (0.945 g, 9 mmol) and DCC (1.440 g, 9 mmol) were added and the mixture kept at 4° overnight. The DCU was filtered off and the filtrate washed with 1 N HCl, H₂O and 1 M NaHCO₃. On drying and evaporating EtOAc the HOSU ester of Boc- γ -benzyl Glu was obtained as a solid, yield = 2.6 g (66%).

The Boc- γ -benzyl Glu-OSu (2.6 g, 6 mmol) was dissolved in THF (10 ml) and a soln of Gln (0.880 g, 6 mmol), Et₃N (0.84 ml, 6 mmol) in H₂O (10 ml) was added. After 12 hr at room temp. the THF was removed, the aqueous was acidified with 1 N HCl and extracted with EtOAc (3 x 20 ml). The organic layer was dried and evaporated. The oily residue was triturated with ether-EtOAc when the dipeptide was obtained as a solid, yield = 1.6 g (57%); m.p. = 125°; $[\alpha]_D^{25} = -15.0$ " ($c = 0.2$ in MeOH).

Boc- γ -benzyl Glu-Gln-Phol **22**. Phenylalaninol (Phol)³⁷ (0.380 g, 2.5 mmol) was added to a soln of **21** (1.16 g, 2.5 mmol) in DMF at 0°. HOBT (0.340 g, 2.5 mmol), DCC (0.515 g, 2.5 mmol) were added and the mixture stirred at room temp. for 24 hr. The DCU was filtered off and the filtrate diluted with EtOAc (25 ml). The organic layer was washed with H₂O, 1 N HCl, H₂O, 1 M NaHCO₃ and dried. On evaporating the ethyl acetate, the tripeptide was obtained as a solid, yield = 0.950 g (60%); m.p. = 165°C; $[\alpha]_D^{25} = -52.5$ " ($c = 0.2$ in MeOH).

Synthesis of Z-Aib-Pro-Aib-Ala-Aib-Ala-Gln-Aib-Val-Aib-Gly-Leu-Aib-OMe (Z-(1-13)-OMe) **23**

Z-(1-6)-OH **9** (0.575 g, 0.9 mmol) was coupled to H₂N-(7-13)-OMe (0.600 g, 0.9 mmol) (obtained by deprotection of **18** by HCl/THF as in the case of **7**) in DMF with DCC-HOBT as in the case of **10**, yield of the crude peptide = 0.700 g (66%).

The peptide was purified by column chromatography on silica gel (1.8 cm x 30 cm, 30 g of silica gel). The peptide was eluted with 5% MeOH/CHCl₃, yield (after chromatography) = 0.560 g (80%); m.p. = 142-145°; $[\alpha]_D^{25} = 17.1$ " ($c = 0.25$ in MeOH).

Single crystals were obtained from MeOH. The cell parameters obtained X-ray diffraction are summarised in Table 3.

Synthesis of Z-Aib-Pro-Aib-Ala-Aib-Ala-Gln-Aib-Val-Aib-Gly-Leu-Aib-Pro-Val-Aib-Aib-OMe **24**

The peptide **23** (0.565 g) was saponified as in the case of **2** with 2 N NaOH to yield the Z(1-13) acid, yield = 0.520 g (90%); m.p. = 150-152°.

The Z(1-13)-acid (0.520 g, 0.45 mmol) was coupled to Pro-Val-Aib-Aib-OMe (0.390 g, 1.0 mmol) (obtained by deprotection of **20** as in the case of **7**) in DMF with DCC-HOBT. Work up was as in the case of **10**, yield of crude peptide = 0.500 g (74%).

The peptide was purified by column chromatography on silica gel (1.8 cm x 30 cm, 25 g of silica gel). The desired peptide was obtained by elution with 5% MeOH/CHCl₃, yield = 0.450 g (90%); m.p. = 155-158°.

Synthesis of Ac-Aib-Pro-Aib-Ala-Aib-Ala-Gln-Aib-Val-Aib-Gly-Leu-Aib-Pro-Val-Aib-Aib-OMe, Ac(1-17)-OMe **25**

Peptide **24** (0.130 g, 0.08 mmol) was dissolved in EtOH. Freshly prepared Pd black (0.100 g) and cyclohexene (5 ml) were added and the mixture refluxed for 1 hr with stirring. The Z-group was removed during the period of 1 hr. The soln was decanted and evaporated. The residue was dissolved in CHCl₃ (15 ml) were added and the mixture stirred at room temp. for 1 hr. The CHCl₃ soln was washed with 1 N HCl, H₂O and dried. On evaporation

of CHCl₃, the desired compound was obtained, yield = 0.115 g (90%); m.p. = 180°.

Ac-(1-17)-OH **26**. The peptide **25** was dissolved in MeOH (1 ml) and 2 N NaOH (1 ml) added to it. After 6 hr, H₂O (5 ml) was added and the aqueous soln was acidified with 2 N HCl. The aqueous layer was extracted with CHCl₃ (3 x 15 ml) and dried. The peptide acid obtained on evaporating CHCl₃ was used directly in the next step.

Synthesis of alamethicin **27**

The Boc group was removed from **22** (0.120 g, 0.2 mmol) with 2 N HCl/THF (10 ml). The hydrochloride was dissolved in DMF (5 ml), cooled to 0° and Et₃N (0.03 ml) added under stirring. After 20 min **26** (0.100 g, 0.6 mmol) was added followed by HOBT (0.015 g, 0.1 mmol) and DCC (0.025 g, 0.1 mmol). The mixture was stirred at room temp. for 48 hr. The DCU was filtered off and the filtrate diluted with CHCl₃ (15 ml). The organic layer was washed with H₂O, 1 N HCl, H₂O, 1 M NaHCO₃ and dried CHCl₃ was evaporated and the residue dissolved in EtOH (15 ml). Freshly prepared Pd black (0.050 g), cyclohexene (3 ml) were added and the mixture was refluxed for 1 hr with stirring. The EtOH soln was then decanted and evaporated. The residue was triturated with ether to give the desired compound, yield = 0.35 g (35%); m.p. = 237°; Lit (natural alamethicin)¹² = 259-260°, 275-279°.

Single crystals were obtained from MeOH. The cell parameters obtained from X-ray diffraction are summarised in Table 3. The characterisation of the peptide is described in the text.

Acknowledgements—This research was supported by grants from the Department of Science and Technology. RN is the recipient of a CSIR fellowship. PB is the recipient of the UGC Career Award. We thank Dr. N. Shamala and M. K. Mathew for the crystal parameters and the fluorescence assay, respectively.

REFERENCES

- 1 G. Jung, N. Dubischar, D. Leibfritz, M. Otnad, H. Probst and Ch. Stumpf, *Peptides 1974*" (Edited by Y. Wolman), p. 343. Wiley, New York (1975).
- 2 A. L. Y. Lau and S. Chan, *Biochemistry* **13**, 4942 (1974).
- 3 H. C. Besch, Jr., L. R. Jones, J. W. Fleming and A. M. Watanabe. *J. Biol. Chem.* **252**, 7905 (1977).
- 4 J. C. Bonnafous, J. Dornand and J. C. Mani, *Biochem. Biophys. Res. Commun.* **86**, 536 (1979).
- 5 L. R. Jones, H. R. Besch, Jr. and A. M. Watanabe. *J. Biol. Chem.* **252**, 3315 (1977).
- 6 P. Mueller and O. Rudin, *Nature* **217**, 713 (1968).
- 7 P. Mueller, *Horizons in Biochemistry and Biophysics* (Edited by E. Quagliariello, F. Palmieri and T. P. Singer), Vol. I, p. 230 (1976).
- 8 G. Boheim, *J. Membrane Biol.* **19**, 227 (1974).
- 9 J. E. Hall, *Membrane Transport in Biology* (Edited by D. C. Tosteson), Vol. I, 475 Springer-Verlag, Berlin, Heidelberg (1978).
- 10 J. W. Payne, R. Jakes and B. S. Hartley, *Biochem. J.* **117**, 757 (1970).
- 11 D. R. Martin and R. J. P. Williams, *Ibid.* **153**, 181 (1976).
- 12 R. C. Pandey, J. Carter Cook, Jr. and K. L. Rinehart, Jr., *J. Am. Chem. Soc.* **99**, 8469 (1977).
- 13 G. R. Marshall and T. M. Balasubramanian, *6th American Peptide Symposium Abstract No. A.111* (1979).
- 14 A. W. Burgess and S. J. Leach, *Biopolymers* **12**, 2599 (1973).
- 15 R. Nagaraj, N. Shamala and P. Balaram, *J. Am. Chem. Soc.* **101**, 16 (1979).
- 16 Ch. P. Rao, R. Nagaraj, C. N. R. Rao and P. Balaram, *FEBS Lett.* **100**, 244 (1979).
- 17 Ch. P. Rao, R. Nagaraj, C. N. R. Rao and P. Balaram, *Biochemistry* **19**, 425 (1980).
- 18 R. Nagaraj, Ph.D. Thesis, Indian Institute of Science, Bangalore, India (1980).
- 19 N. Shamala, R. Nagaraj and P. Balaram, *Biochem. Biophys. Res. Commun.* **79**, 292 (1977).
- 20 N. Shamala, R. Nagaraj and P. Balaram, *J. Chem. Soc. Chem. Commun.* **9** (1978).

- ²¹B. V. V. Prasad, N. Shamala, T. Nagaraj, R. Chandrasekaran and P. Balam, *Biopolymers* **18**, 1635 (1979).
- ²²B. V. V. Prasad, N. Shamala, R. Nagaraj and P. Balam, *Acta Cryst.* **B36**, 107 (1980).
- ²³W. Konig and R. Geiger, *Chem. Ber.* **10**, 788 (1970).
- ²⁴G. M. Anantharamiah and K. M. Sivanandaiah, *J. Chem. Soc. Perkin I* 491 (1977).
- ²⁵W. J. McGahren and M. Goodman, *Tetrahedron* **23**, 2017 (1967).
- ²⁶R. Nagaraj and P. Balam, *Heterocycles* **7**, 885 (1977).
- ²⁷R. Nagaraj and P. Balam, submitted for publication.
- ²⁸D. F. Veber, *Peptides: Chemistry, Structure and Biology* (Edited by R. Walter and J. Meienhofer), p. 307. Ann Arbor. Michigan (1975).
- ²⁹I. J. Galpin, F. E. Hancock, B. K. Handa, A. G. Jackson, G. W. Kenner, R. Ramage, B. Singh and R. G. Syson, *Tetrahedron* **35**, 2779 (1979).
- ³⁰G. Jung, N. Dubischar and D. Leibfritz, *Eur. J. Biochem.* **54**, 395 (1975).
- ³¹R. Nagaraj, M. K. Mathew and P. Balam, *FEBS Lett.* **121**, 365 (1980).
- ³²B. F. Gisin, S. Kobayashi and J. E. Hall, *Proc. Natl. Acad. Sci. USA* **74**, 115 (1977).
- ³³B. F. Gisin, S. Kobayashi, D. G. Davis and J. E. Hall, *Peptides* (Edited by M. Goodman and J. Meienhofer), p. 215. Wiley, New York (1977).
- ³⁴W. Mayr, R. Oekonomopulos and G. Jung, *Biopolymers* **18**, 425 (1979).
- ³⁵M. Brenner and W. Huber, *Helv. Chim. Acta* **36**, 1109 (1953).
- ³⁶J. T. Gerig and R. S. McLeod, *J. Org. Chem.* **41**, 1653 (1976).
- ³⁷H. Seki, K. Koya, H. Matsuo, S. Ohki, I. Matsuo and S. Yamada, *Chem. Pharm. Bull.* **13**, 995 (1965).