

# Cavitation: A technology on the horizon

Parag R. Gogate<sup>1</sup>, Rajiv K. Tayal<sup>2</sup> and Aniruddha B. Pandit<sup>1,\*</sup>

<sup>1</sup>Chemical Engineering Department, Institute of Chemical Technology, Matunga, Mumbai 400 019, India

<sup>2</sup>Department of Science and Technology, Technology Bhavan, New Mehrauli Road, New Delhi 110 016, India

**An overview of the application of cavitation phenomenon for the intensification of chemical/physical processing applications has been presented here, discussing the causes for the observed enhancement and highlighting some of the typical examples. The important considerations required for efficient scale-up of the cavitation reactors and subsequent industrial applications have been depicted based on the work carried out as a result of sponsored projects at the Institute of Chemical Technology, Mumbai. Overall, it appears that the combined efforts of physicists, chemists and chemical engineers are required to effectively use cavitation reactors for industrial applications. Some recommendations for further work to be carried out in this area have also been mentioned, which should allow the exploitation of this technology on an industrial scale.**

**Keywords:** Acoustic cavitation, chemical processing, hydrodynamic cavitation, novel reactors, process intensification.

CAVITATION can be in general defined as the generation, subsequent growth and collapse of cavities resulting in very high energy densities of the order of 1 to  $10^{18}$  kW/m<sup>3</sup>. Cavitation can occur at millions of locations in a reactor simultaneously and generate conditions of very high temperatures and pressures (few thousand atmospheres pressure and few thousand Kelvin temperature) locally, with the overall environment being that of ambient conditions. Thus, chemical reactions requiring stringent conditions can be effectively carried out using cavitation at ambient conditions. Moreover, free radicals are generated in the process due to the dissociation of vapours trapped in the cavitating bubbles, which results in either intensification of the chemical reactions or in the propagation of certain unexpected reactions. Cavitation also results in the generation of local turbulence and liquid micro-circulation (acoustic streaming) in the reactor, enhancing the rates of transport processes.

The four principle types of cavitation and their causes can be summarized as follows:

## *Acoustic cavitation*

In this case, pressure variations in the liquid are effected using sound waves, usually ultrasound (16 kHz–100 MHz).

The chemical changes associated with the cavitation induced by the passage of sound waves are commonly termed as sonochemistry.

## *Hydrodynamic cavitation*

Cavitation is produced by pressure variations, which is obtained using the geometry of the system creating velocity variation. For example, based on the geometry of the system, the interchange of pressure and kinetic energy can be achieved resulting in the generation of cavities as in the case of flow through orifice, venturi, etc.

## *Optic cavitation*

This is produced by photons of high intensity light (laser) rupturing the liquid continuum.

## *Particle cavitation*

This is produced by a beam of elementary particles, e.g. a neutron beam rupturing a liquid, as in the case of a bubble chamber.

## **Applications of cavitation phenomenon**

Among the various modes of generating cavitation given above, acoustic and hydrodynamic cavitations have been of academic and industrial interest due to the ease of operation and generation of the required intensities of cavitation conditions suitable for different physical and chemical transformations. It is worthwhile to overview different applications where cavitation can be used efficiently before discussing the design and scale-up aspects for these two types of cavitation in detail.

## *Chemical synthesis*

In order to understand the way in which cavitation collapse can affect chemical transformations, one must consider the possible effects of this collapse in different systems. In the case of homogeneous liquid phase reactions, there are two major effects. First, the cavity that is formed is unlikely to enclose a vacuum (in the form of void) – it will almost certainly contain vapour of the liquid medium

\*For correspondence. (e-mail: abp@udct.org)

or dissolved volatile reagents or gases. During the collapse, these vapours will be subjected to extreme conditions of high temperatures and pressures, causing molecules to fragment and generate highly reactive radical species. These radicals may then react either within the collapsing bubble or after their migration into the bulk liquid. Secondly, the sudden collapse of the bubble also results in the rushing-in of the liquid to fill the void, producing shear forces in the surrounding bulk liquid capable of breaking the chemical bonds of many polymeric materials resulting into lower molecular weight polymeric forms, which are dissolved in the fluid or disturb the boundary layer facilitating transport.

The sonochemical activation in heterogeneous systems is mainly due to the mechanical effects of cavitation. In a heterogeneous solid/liquid system, the collapse of the cavitation bubble results in significant structural and mechanical defects. Collapse near the surface produces an asymmetrical rushing-in of the fluid to fill the void, forming a liquid jet targetted at the surface. This effect is equivalent to high-pressure/high-velocity liquid jets-based cutting and/or erosion and is the reason why ultrasound is used for cleaning solid surfaces. These jets activate the solid catalyst and increase mass transfer to the surface by disruption of the interfacial boundary layers as well as dislodging the material occupying the active sites. Collapse on the surface, particularly of powders, produces enough energy to cause fragmentation (even for finely divided metals). Thus, in this situation, ultrasound can increase the surface area for a reaction and provide additional activation through efficient mixing and enhanced mass transport.

In heterogeneous liquid-liquid reactions, cavitation collapse at or near the interface will cause disruption and mixing, resulting in the formation of very fine emulsions. When such emulsions are formed, the surface area available for the reaction between the two phases is significantly increased, thus increasing the rates of reaction. This is beneficial, particularly in the case of phase transfer-catalysed reactions or biphasic systems.

The different ways in which cavitation can be used beneficially in the chemical processing applications are<sup>1-10</sup>:

- (a) Reaction time reduction.
- (b) Increase in the reaction yield.
- (c) Use of less forcing conditions (temperature and pressure) compared to the conventional routes.
- (d) Reduction in the induction period of the desired reaction.
- (e) Possible switching of the reaction pathways resulting in increased selectivity.
- (f) Increasing the effectiveness of the catalyst used in the reaction.
- (g) Initiation of the chemical reaction due to generation of highly reactive free radicals.

### *Water and effluent treatment*

Cavitation can be used effectively for the destruction of contaminants in water because of the localized high concentration of oxidizing species such as hydroxyl radicals and hydrogen peroxide, higher magnitudes of localized temperatures and pressures and formation of transient supercritical water. The type of pollutants in the effluent stream affects the rates of the degradation process. Hydrophobic compounds react with OH<sup>•</sup> and H<sup>•</sup> at the hydrophobic gas/liquid interface, while the hydrophilic species react to a greater extent with the OH<sup>•</sup> radicals in the bulk aqueous phase. Optimization of aqueous phase organic compound degradation rates can be achieved by adjusting the energy density, energy intensity and nature and properties of the saturating gas in solution.

The variety of chemicals that have been degraded using acoustic cavitation, though in different equipments and on a wide range of operating scales<sup>11,12</sup> are *p*-nitrophenol, rhodamine B, 1,1,1 trichloroethane, parathion, pentachlorophenolate, phenol, CFC 11 and CFC 113, *o*-dichlorobenzene and dichloromethane, potassium iodide, sodium cyanide and carbon tetrachloride among many others.

### *Biotechnology*

Cell disruption is one of the important and vital unit operations in biotechnology for the recovery of intracellular proteins. This is an energy-intensive operation and hence there exists tremendous scope for the development of cheaper and energy-efficient methods. Cavitation can be used effectively for the rupture of cells with energy requirements as less as just 5 to 10% of the total energy consumed using conventional methods<sup>13,14</sup>. The intensity of the cavitation phenomenon can also be controlled so as to control the mechanism of rupture of cells, to selectively release the intracellular enzymes or enzymes present in the cell wall<sup>15</sup>. Lower intensity application of cavitation helps in retaining the activity of the leached-out enzymes and also reduces the cost of operation. Hydrodynamic cavitation has been found to be much more energy-efficient compared to acoustic cavitation and at the same time applicable at a larger scale of operation<sup>13,14</sup>.

### *Sonocrystallization*

Sonocrystallization can be used to impart a variety of desirable characteristics to high-value products. Dow Chemical, USA is already using sonocrystallization for adipic acid crystallization, but it is a closely guarded secret. Impurities have been reduced from 800 to less than 50 ppm. Ultrasound can be used beneficially in several key areas of crystallization such as:

- Initiation of primary nucleation, narrowing the metastable zone width.

- Secondary nucleation.
- Crystal habit and perfection.
- Reduced agglomeration.
- A non-invasive alternative to the addition of seed crystal (seeding) in sterile environment.
- Manipulation of crystal distribution by controlled nucleation.

The formation of primary nuclei is a function of ultrasonic parameters such as frequency of oscillations, intensity of irradiation and physical properties of the liquid such as degree of supersaturation and operating parameters such as temperature.

### Atomization

Atomization is the process of formation of small droplets. Energy is imparted to the liquid to form a large surface area. The conventional way to atomize the liquid is to force it at high velocity through a small aperture. In the two-phase atomization system, the high-velocity air imparts its energy to the liquid sheet breaking it into droplets. When liquid in the form of thin film is allowed to flow at the tip of the vibrating surface (frequency >20 kHz), the film breaks up into fine droplets. This is called as ultrasonic atomization. There are two hypotheses that explain the mechanism of liquid disintegration during ultrasonic atomization – capillary wave hypothesis and cavitation hypothesis. The means of controlling droplet size is desirable in many industrial applications, and this will only be achieved by a close study of the mechanism of break-up of liquid sheets/ligaments.

The droplet size in case of ultrasonic atomization is a function of:

- Physico-chemical properties of the liquid such as surface tension, density, viscosity, including non-Newtonian behaviour.
- Ultrasonic parameters such as frequency of oscillation and intensity of irradiation.
- Operating parameters such as liquid flow rate, liquid loading on the atomizing surface area and shape of the liquid film due to the geometry of the surface.

These just cover the broad spectrum of applications of cavitation; there are many other specific applications of both acoustic and hydrodynamic cavitation. Acoustic cavitation has been found to be beneficial in polymer chemistry applications for initiation of polymerization reactions or for destruction of complex polymers<sup>16–18</sup>, solid-liquid extraction<sup>19</sup> as well as in the petroleum industry for refining fossil fuels, in the determination of composition of coal extracts, extraction of coal tars<sup>20,21</sup>, and in textile industry for enhancing the efficacy of dyeing techniques<sup>22,23</sup>. Some of the miscellaneous applications of hydro-

dynamic cavitation can be given as floatation cells<sup>24,25</sup>, synthesis of nanocrystalline materials<sup>26</sup>, preparation of high quality quartz sand<sup>27</sup>, preparation of free disperse system using liquid hydrocarbons<sup>28,29</sup> and dental water irrigator<sup>30</sup>.

A careful analysis of the existing literature shows that though the application of cavitation to physical/chemical processing has been explored worldwide for a good 50 years, the first report from an Indian group regarding the use of hydrodynamic cavitation for chemical/physical processing applications dates back only to 1993 (study on hydrolysis of fatty oils by Pandit and Joshi<sup>31</sup>). We now discuss the evolution of technology with specific reference to work carried out in India (more than 95% of the work is by the group at the Institute of Chemical Technology, Mumbai), highlighting the current status of information related to applications of cavitation.

### Overview of different reactor configurations

In this section, we discuss the various equipment configurations and their scales commonly available for carrying out the cavitation phenomenon. For better understanding specific configurations as available with our research group have been discussed. It should be noted that different variants of these configurations are available with varying operating parameters like the maximum power supplied to the reactor, frequency of irradiation, geometric arrangements of the transducers (in the case of sonochemical reactors), geometric arrangement of the hole, capacity of the pump (in the case of hydrodynamic cavitation reactors).

#### Sonochemical reactors

##### *Ultrasonic horn and bath*

A schematic diagram of these standard configurations has been depicted in Figure 1. The horn operates at a frequency of 22.7 kHz and a rated power dissipation of 240 W. Two different tips (irradiating surface area of 3.46 and 4.91 cm<sup>2</sup>) can be used so as to change the operating intensity of irradiation (defined as power dissipated per unit area of the horn). The capacity of the reactor generally ranges from 10 to 200 ml. Ultrasonic horn-type of configurations are generally suitable for laboratory-scale characterization/feasibility experiments, as they provide intense but local cavitation.

The ultrasonic bath has a fixed operating frequency of 22 kHz (one can get these at different operating frequencies) with a rated output power of 120 W (again variable power dissipation is possible). Three transducers are placed at the bottom of the reactor in a triangular pitch. The maximum operating capacity of the ultrasonic bath is about 3 l, but in general baths with higher capacity (up to 1000 l) can be used with some modification in terms of larger number of transducers in different configurations.

Again, ultrasonic bath-type of reactors are suitable for laboratory to pilot-scale operations, as there is a limitation on the number of transducers that can be incorporated in the system for a large-scale operation.

*Dual-frequency flow cell*

The flow cell (Figure 2) consists of a rectangular vessel with a diameter of 9.5 cm and height of 20 cm (1.5 l capacity to hold the reacting mixture), with two sets of transducers (three in each set) mounted on the two opposite faces. Transducers operating (independently or simultaneously) at different frequencies, i.e. 25 and 40 kHz and having equal power rating of 120 W per set have been provided. The flow cell can be operated in a batch or continuous mode.

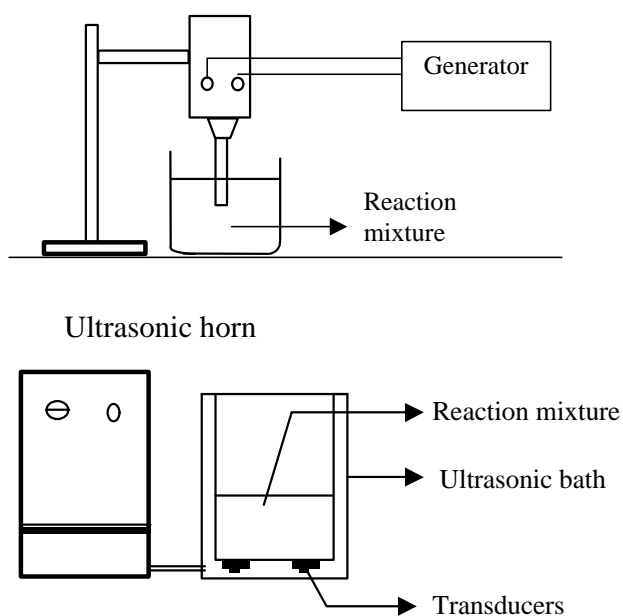

**Figure 1.** Schematic representation of ultrasonic horn and ultrasonic bath.

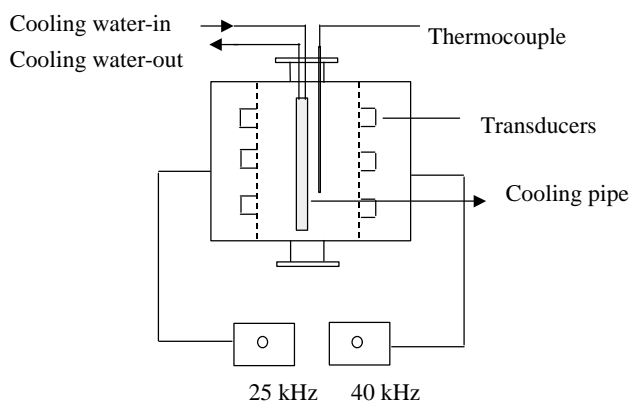

**Figure 2.** Schematic representation of dual-frequency flow cell.

*Triple-frequency flow cell*

The hexagonal triple-frequency flow cell has a total capacity of 7.5 l and can be operated in batch as well as continuous mode. Transducers (three in each set per side) having equal power rating of 150 W per side have been mounted (thus the total power dissipation is 900 W when all the transducers with combination of 20 + 30 + 50 kHz frequencies are functional). The two opposite faces of the flow cell have a similar irradiating frequency. The operating frequency of transducers is 20, 30 and 50 kHz and can be operated in different combinations (seven in total), either individually or in combined mode. Schematic representation of hexagonal flow cell is given in Figure 3.

*Ultrasonic bath with longitudinal vibrations*

The reactor is irradiated using a single longitudinally vibrating transducer (vibrations are away from the bottom of the reactor) kept at the bottom of the reactor. The advantage of such a configuration is that due to large area of the irradiating surface, the active cavitation volume in the reactor is higher resulting in better cavitation yields through a large number of cavities. The schematic representation of the reactor is depicted in Figure 4. The inner cross-section of the reactor has dimensions of 15 cm × 33 cm × 20 cm with a total holding capacity of 8 l (some part of the reactor is occupied by the transducer). There is provision for a drain as well as an outlet at the top, which facilitates continuous operation. An additional heater with a temperature controller has been provided so as to facilitate high temperature reactions. The operating frequency of irradiation is 36 kHz and maximum power dissipation

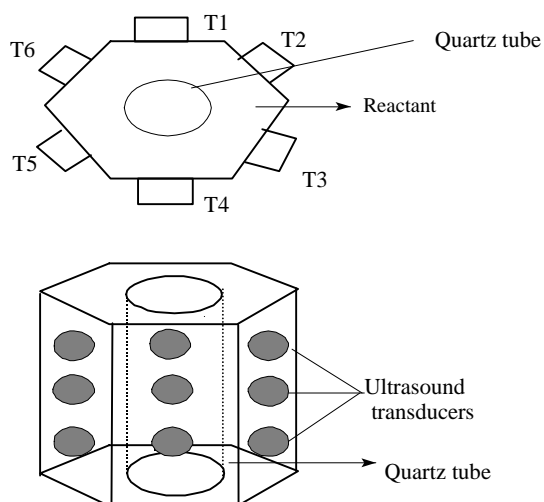

Hexagonal reactor with 10 cm sides. The central quartz tube can be used for simultaneous irradiation with UV light.

**Figure 3.** Schematic representation of triple-frequency hexagonal flow cell.

into the system is 150 W (operation with varying power dissipation is also possible).

## Hydrodynamic cavitation reactors

### High-pressure homogenizer

The high-pressure homogenizer (APV Gualin GmbH model) is basically a high-pressure positive displacement pump with a throttling device. This homogenizer operates according to the principle of high-pressure relief technique. The reactor configuration generally consists of a feed tank and multiple throttling valves designated as multiple stages of throttling. In the configuration available with our research group, the liquid from the feed tank (capacity of 1500 ml) is driven by a pump to the first-stage valve. Pressure up to 1000 psi ( $6.895 \times 10^6 \text{ N/m}^2$ ) can be attained by throttling this valve. Further increase in pressure is achieved using the second-stage valve. Upstream pressure up to 10000 psi ( $6.895 \times 10^7 \text{ N/m}^2$ ) can be obtained in the second stage. From the second stage valve, the liquid is recirculated back to the feed tank. The cavitating conditions are generated just after the second-stage throttling valve. When the liquid is suddenly released from the second-stage, evaporation takes place giving rise to cavities/bubbles. The cavitation intensity will be dependent on the magnitude of upstream pressure and also on the type of valve at the second stage. With an increase in the throttling pressure, there is a rise in the temperature of the liquid. To maintain the temperature at ambient conditions, a coil immersed in the feed tank can be used for circulation of the cooling water. High-pressure homogenizers are especially suitable for emulsification processes in industries like food, chemical, pharmaceutical and biochemical and are available at industrial scales, though the configurations may not be the most ideal for these equipment to operate in optimized cavitating conditions.

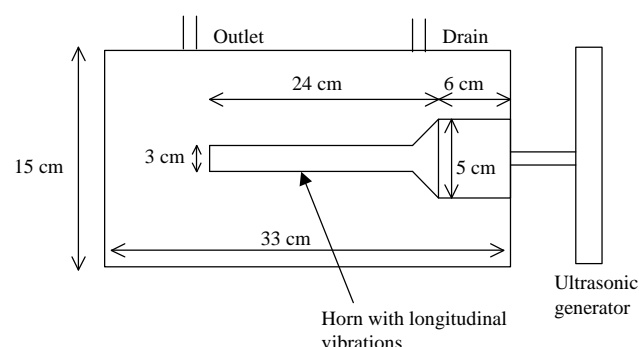

Drain is at 8 cm height from the bottom of reactor whereas the outlet is at a height of 32 cm from the bottom so as to facilitate continuous operation

**Figure 4.** Schematic representation of ultrasonic bath equipped with longitudinally vibrating horn.

### High-speed homogenizer

The high-speed homogenizer consists of an impeller (rotor) and a stator, which are made up of stainless steel. The impeller is driven by a variable voltage motor (the limit permitted for the homogenizer is 30 V or 3.5 A, resulting into a maximum rotational speed of 16000 rpm). The distance between the impeller and stator can be varied using different geometric configurations of the impeller and stator, and this distance along with the operating parameters decides the cavitation zone. Various combinations are available with our group, e.g. a combination having an impeller with nine blades, while the stator has 13 blades. The impeller blades are 6 mm apart whereas the distance between two stator blades is 6 mm. The distance between the OD of the impeller blade and the ID of the stator blade can be varied over a range of 0.5 to 2 mm. A plate with holes attached to the stator top has been provided, which can be used for inserting baffles so as to avoid vortex formation and surface aeration that decreases the intensity of cavitation. The cavitating conditions are generated after the liquid passes through the stator-rotor assembly, according to principle similar to the orifice plates set-up, which is described later. As one increases the rotor speed, the liquid velocities generated increase and beyond a certain speed defined as the critical inception speed for the cavitation, cavities are formed due to the fact that local pressure falls below the vapour pressure of the medium. A re-circulating loop similar to the one depicted for the case of high-pressure homogenizer can be used for operation with high-speed homogenizers.

### Orifice plates set-up

The set-up consists of a closed loop fluid circuit comprising a holding tank, a centrifugal pump, control valve and flanges to accommodate the orifice plates, as shown in Figure 5. The suction side of the pump is connected to the bottom of the tank. Discharge from the pump branches

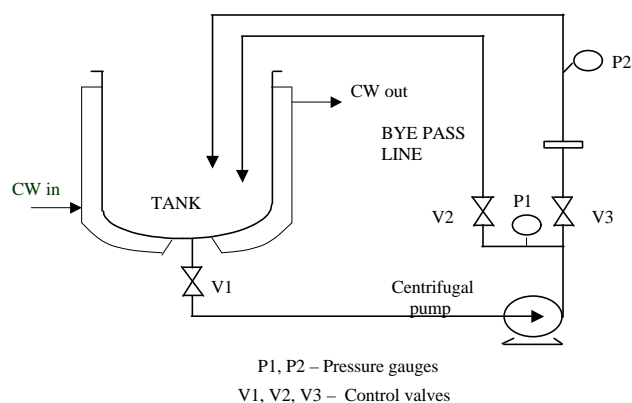
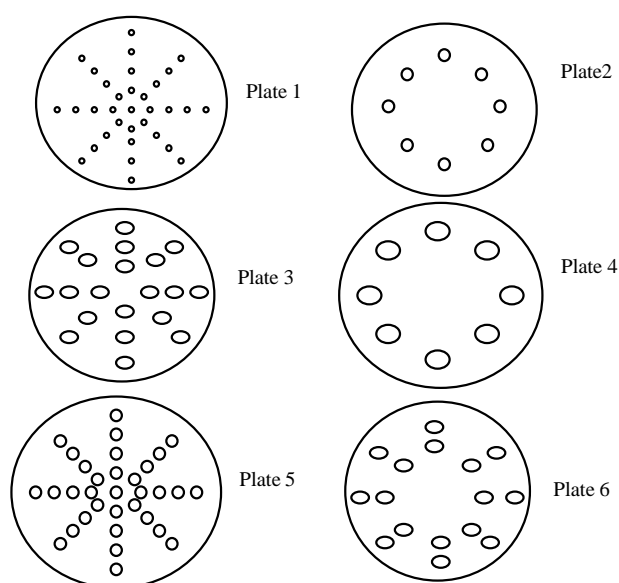

**Figure 5.** Schematic representation of orifice plate set-up.

into two lines, which help in the control of inlet pressure and inlet flow rate into the main line housing the orifice with the help of valves  $V_2$  and  $V_3$ . The main line consists of a flange to accommodate the orifice plates (single or multiple holes); different configurations of the orifice plates have been shown in Figure 6, along with a hard glass tube next to these plates to make visual observation. The cavitating conditions are generated just after the orifice plates in the main line and hence the intensity of the cavitating conditions strongly depends on the geometry of the orifice plate. When the liquid passes through the orifice plates, the velocities at the orifice increase due to the sudden reduction in the area offered for the flow, resulting in a decrease in the pressure. If the velocities are such that their increase is sufficient to allow the local pressure to go below the medium vapour pressure under operating conditions, cavities are formed. Such cavities are formed at a number of locations in the reactor, which also depends strongly on the number of holes in the orifice plates. At the downstream of the orifice, however, due to an increase in the area of cross-section, the velocities decrease giving rise to increasing pressures and pressure fluctuations, which control the different stages of cavitation, namely formation, growth and collapse. The holding tank is provided with a cooling jacket to control the temperature of the circulating liquid. The inlet pressure and the fully recovered downstream pressure can be measured with the pressure gauges  $P_1$  and  $P_2$  respectively.

### Comparison of cavitation reactors

After giving an insight into the different aspects of the reactor configurations, we now discuss the comparison of



**Figure 6.** Multiple-hole orifice plates having different combinations of number and diameter of holes.

different cavitation reactors to provide recommendations for selection of reactor type to carry out specific cavitation transformation.

### Energy efficiency calculations

Calorimetric method is generally used to determine the energy efficiency of the equipment. In this method, the rise in temperature of a fixed quantity of water in an insulated container over a given time is measured. Using this information, the actual energy (power) dissipated into a liquid can be calculated from the following equation:

$$\text{Power (watt)} = mC_p (dT/dt), \quad (1)$$

where  $C_p$  is the heat capacity of the solvent ( $\text{J kg}^{-1} \text{K}^{-1}$ ),  $m$  the mass of solvent (kg),  $dT$  the difference between the initial and final temperature after a specific reaction time (K), and  $dt$  is time (s). Energy efficiency can be then calculated as follows:

$$\text{Energy efficiency} = \frac{\text{Power dissipated in the liquid/}}{\text{electric power supplied to the system.}}$$

Energy efficiency gives an indication of the quantity of energy effectively dissipated in the system, a fraction of which is actually utilized for the generation of cavities. Thus both should be as high as possible for the particular equipment.

### Cavitation yield calculations

The cavitation yield of an acoustic equipment indicates the ability of the equipment to produce the desired cavitation change based on the total electric energy supplied to the equipment. Details about the estimation of cavitation yield have been discussed in detail in the earlier sections.

### Important results

In all cavitation equipments, the primary form of energy supplied as input is electrical energy. This energy goes through various changed forms, i.e. pressure, velocity, vibrations, etc. before it is used to generate cavitation, resulting in the desired chemical change. In most cases, the electrical energy is converted to mechanical energy (vibratory motion of the transducer in acoustic equipments and liquid flow with pressure in hydrodynamic cavitation equipments). The mechanical energy is used to generate cavitation and finally the violent collapse of generated cavities dissipates this diffused form of energy by concentrating it through a number of cavitation events and induces chemical reactions. In each case, there is a continuous loss of energy during its transformation from one

form to another and hence the comparison of the energy efficiency can aid in understanding the productive energy utilization of various equipments for the desired cavitation activity.

The results of the study for energy efficiency as obtained in various cavitation equipment described earlier are given in Figure 7a. It can be observed that amongst sonochemical reactors, the triple-frequency flow cell is the most energy efficient (energy efficiency of about 75%) due to uniform energy dissipation over a wider area and through multiple transducers (three each on six sides of the hexagonal cross-section), rather than concentrated energy dissipation in the horn (energy efficiency <10%). Efficiency of the dual-frequency flow cell (56%) was also found to be equally good, due to the fact that the energy is dissipated over a wider area and through multiple transducers. The ultrasonic bath which has three transducers, attached at the bottom of the reactor gives an energy efficiency of about 20%, twice compared to ultrasonic horn. Thus multiple transducer irradiation is the key for

maximizing the transfer of energy into the system for sonochemical reactors. Amongst the hydrodynamic cavitation equipments, high speed and high pressure homogenizers (typically laboratory-scale equipment with capacity of 1.5 and 2 l respectively) have energy efficiency of 43 and 54% respectively. The orifice type of hydrodynamic cavitation reactor having a capacity of 50 l (typically a pilot-plant scale) has an observed energy efficiency of 60%. Conventionally speaking, hydrodynamic cavitation equipment are more energy-efficient compared to the acoustic counterparts (except for the multiple-frequency flow cells), though the exact cavitation effects may or may not follow similar trends, as the fraction of this energy utilized for the cavitation activity is different.

Figure 7b also gives the values of cavitation yields obtained for different equipment for the Weissler reaction. It can be seen from Figure 7b that amongst sonochemical reactors, triple-frequency flow cell gives an order of magnitude higher cavitation yield as compared to all the other equipment. Dual-frequency flow cell also gives 20% higher yield compared to ultrasonic bath, whereas the cavitation yield obtained in the case of single transducer-based ultrasonics is the lowest (two orders of magnitude lower). Similar results were also obtained for another reaction (degradation of formic acid), which requires significantly higher cavitation activity compared to the Weissler reaction, indicating that the intensity requirements for a particular reaction do not necessarily affect the trends. Thus multiple transducer irradiation also results in an enhancement in the cavitation yield and these types of reactors should play a key role in the design of industrial-scale reactors. Another feature of the flow cells used in the present work is the possibility of continuous operation, which is a key requirement for the industrial-scale operation. It should also be noted at this stage that the triple-frequency flow cell as well as the dual-frequency flow cell have a flexibility of multiple frequency operation (for comparison purposes in the present work, only single frequency irradiation has been considered). At this stage, it is not possible to make any recommendation about the applicability of multiple frequency irradiations for process intensification and synergistic effects, but the results are found to be dependent on the type of reaction<sup>32</sup>.

It can be also seen from Figure 7b that the desired chemical change is an order of magnitude higher for a given amount of electrical energy supplied to the system for the hydrodynamic cavitation reactors compared to the sonochemical reactors. However, it should be noted that the comparison made here is valid only for a model reaction (decomposition of potassium iodide) and the efficiencies of the various equipment may or may not be the same for a variety of cavitation transformations and also other applications. To get more insight into the relative efficacies of the hydrodynamic and acoustic cavitation reactors, we now discuss some chemical synthesis applications of cavitation reactors.

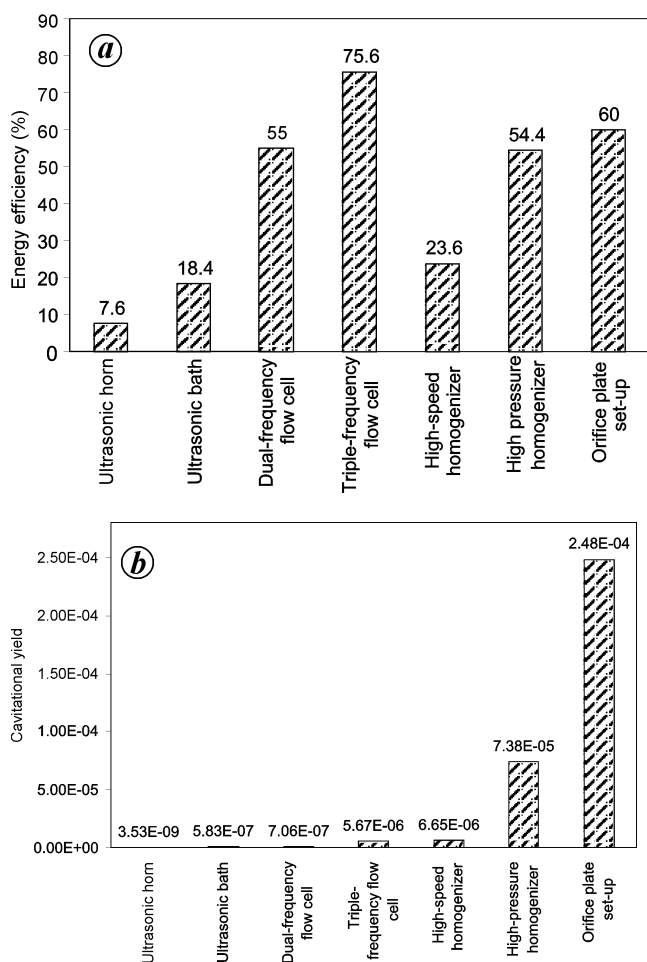

**Figure 7.** Comparison of different cavitation equipments in terms of energy efficiency (a) and cavitation yield (b). Numbers at the top of the columns represent the exact values obtained for the particular dataset.

**Table 1.** Comparative results for different industrially important reactions in hydrodynamic<sup>a</sup> and acoustic<sup>b</sup> cavitation reactors

Reactant	Product <sup>c</sup>	Cavitation yield in hydrodynamic cavitation reactor (g/J)	Cavitation yield in acoustic cavitation reactor (g/J)
Toluene	Benzoic acid	$3.3 \times 10^{-6}$	$5.6 \times 10^{-7}$
<i>p</i> -Xylene	Terephthalic acid	$2.1 \times 10^{-6}$	$3 \times 10^{-7}$
<i>o</i> -Xylene	Phthalic acid	$1.9 \times 10^{-6}$	$3 \times 10^{-7}$
<i>m</i> -Xylene <sup>d</sup>	Isophthalic acid	$1.9 \times 10^{-6}$	–
Mesitylene	Trimesic acid	$7 \times 10^{-6}$	$1 \times 10^{-7}$
<i>o</i> -Nitrotoluene	<i>o</i> -Nitrobenzoic acid	$1.9 \times 10^{-6}$	$1 \times 10^{-7}$
<i>m</i> -Nitrotoluene	<i>m</i> -Nitrobenzoic acid	$1.3 \times 10^{-6}$	$1 \times 10^{-7}$
<i>p</i> -Nitrotoluene <sup>e</sup>	<i>p</i> -Nitrobenzoic acid	–	$3 \times 10^{-7}$
<i>o</i> -Chlorotoluene	<i>o</i> -Chlorobenzoic acid	$1.1 \times 10^{-6}$	$1 \times 10^{-7}$
<i>p</i> -Chlorotoluene <sup>f</sup>	<i>p</i> -Chlorobenzoic acid	$2 \times 10^{-6}$	–
Sunflower oil	Bio-diesel (methyl ester of sunflower oil)	$2.1 \times 10^{-6*}$	$5.1 \times 10^{-7*}$

<sup>a</sup>Toluene (1 mol), (*o*-/*p*-/*m*-xylene (0.5 mol), mesitylene (0.4 mol), (*o*-/*m*-nitrotoluene (1 mol) and (*o*-/*p*-chlorotoluene (1 mol), sunflower oil (1 mol) with excess of methanol, KMnO<sub>4</sub> for all reactions except for sunflower oil (2 mol), and for all above reactions, water (5 l), pressure 3 kg/cm<sup>2</sup>, orifice plate no. 1. Time = 5 h, except for oxidation of toluene, where it is 3 h and trans-esterification, where it is 30 min.

<sup>b</sup>Toluene (10 mmol), (*o*-/*p*-xylene (5 mmol), mesitylene (4 mmol), (*o*-/*m*-/*p*-nitrotoluene (10 mmol) and *o*-chlorotoluene (10 mmol), sunflower oil (1 mol) with excess of methanol, KMnO<sub>4</sub> for all reactions except for sunflower oil (20 mmol), and for all above reactions, water (50 ml). Time = 5 h except for oxidation of toluene where it is 3 h and trans-esterification, where it is 15 min.

<sup>c</sup>Identification of compounds was done by TLC and melting point.

<sup>d</sup>Not used in acoustic cavitation.

<sup>e</sup>This compound is not used in hydrodynamic cavitation.

\*In mol/J.

Different chemical reactions (oxidation of toluene, (*o*-/*p*-/*m*-xylenes, mesitylene, (*o*-/*m*-nitrotoluenes and (*o*-/*p*-chlorotoluenes and trans-esterification reaction) have been carried out in 10-l capacity orifice plate hydrodynamic cavitation reactor (under optimized conditions, viz. inlet pressure 3 kg/cm<sup>2</sup>, 0.4 mol/l of the oxidant – beyond these values, the increase in the cavitation yield is only marginal – and orifice plate with more number of holes) and also in conventional sonochemical reactor (ultrasonic bath, reaction volume 55 ml, power dissipation 120 W and operating frequency 20 kHz). For comparison purpose, cavitation yield has been used, which is defined as the quantity of product formed per unit of supplied energy. Table 1 shows the values of cavitation yields obtained for all the reactions in hydrodynamic and acoustic cavitation reactors (the specific operating conditions are mentioned as footnote for Table 1). It can be seen from Table 1 that the cavitation yield values in the hydrodynamic cavitation reactors are an order of magnitude higher for all the reactions considered in the work. Also the processing volume is about 100 times more compared to the conventional sonochemical reactor. The results have conclusively proved the better efficacy of the hydrodynamic cavitation reactors compared to the ultrasonic bath reactor considered in the work. Similar results have been also obtained earlier (degradation of potassium iodide<sup>33</sup>, destruction of *p*-nitrophenol<sup>34</sup> and microbial cell disruption<sup>13,14</sup>).

### What can cavitation achieve?

After looking into the general applications of cavitation, in this section we will discuss specific industrially important applications.

### Transesterification of vegetable oils using alcohol

Various products derived from vegetable oils have been proposed as an alternative fuel for diesel engines; crude vegetable oil, a mixture of vegetable oil with petroleum diesel fuel and alcohol esters of vegetable oil appear to be the most promising alternative. Today ‘bio-diesel’ is the term applied to esters of simple alkyl fatty acids used as an alternative to petroleum-based diesel fuels.

Vegetable oil could be used as bio-diesel, but its properties (high viscosity leads to poor atomization of the fuel, incomplete combustion and fuel injector fouling) are not perfectly suitable for diesel engines. Esters of fatty acids with alcohols have been prepared by the transesterification of triglycerides in the presence of a catalyst to produce alcohol esters of fatty acids (bio-diesel fuel) and glycerine as a by-product. Bio-diesel fuels have advantages over petroleum diesel fuel as they produce less carbon monoxide, smoke and particles, have higher cetane number, are biodegradable, non-toxic and have lower viscosity than vegetable oils.

The transesterification reaction of vegetable oils using base catalyst and short-chain alcohols was studied in the presence of hydrodynamic cavitation and compared with the results of the reaction under acoustic cavitation in terms of their energy utilization. The main objectives of this study were comparison of hydrodynamic cavitation and acoustic cavitation in terms of their energy utilization, the study of this reaction at pilot plant-scale of operation and preparation of alkyl esters of fatty acids used as bio-diesel fuel. This is a rapid technique for preparing alkyl esters from triglycerides at pilot plant-scale of operation. Various parameters, such as ratio of vegetable oil to alco-



**Table 2.** Transesterification of different vegetable oils

Vegetable oil	Product	Time (in min)		Yield (%)	
		Acoustic	Hydrodynamic	Acoustic	Hydrodynamic
Soyabean oil	Soyabean oil ester	15	15	97	98
Castor oil	Castor oil ester	10	10	99	99
Peanut oil	Peanut oil ester	10	10	99	90

Acoustic cavitation – vegetable oil (4 g), methanol (4 ml), NaOH (0.5%).

Hydrodynamic cavitation – vegetable oil (4000 g), methanol (4000 ml), NaOH (1%),  $P = 1 \text{ kg/cm}^2$ .

**Table 3.** Comparison of energy efficiency for different techniques

Technique	Time (min)	Yield (%)	Yield/kJ of energy
Acoustic <sup>+</sup>	10	99	$8.6 \times 10^{-5}$
Hydrodynamic*	15	98	$3.37 \times 10^{-3}$
Conventional**			
with stirring	180	98	$2.27 \times 10^{-5}$
under reflux	15	98	$7.69 \times 10^{-6}$

<sup>+</sup>In acoustic cavitation, 4 ml of methanol is mixed with 4 g of vegetable oil and catalyst concentration (NaOH) used is 0.5% of oil. Ultrasonic bath is the sonochemical reactor with 20 kHz frequency and 85 W as power dissipation.

\*Operation with hydrodynamic cavitation is under optimized conditions: 4:4 ratio (w/v) of oil to alcohol, catalyst concentration (NaOH) is 1% of oil. Orifice plate 1 has 16 holes with 2 mm diameter. Volume of methanol is 4000 ml, with 4000 g of oil.

\*\*For conventional approach, 4 ml of methanol is mixed with 4 g of vegetable oil and catalyst concentration (NaOH) used is 0.5% of oil (Case I: a stirrer is used for uniform mixing which consumes energy. Case II: a heater is used for maintaining reflux conditions).

hol, type of catalyst, ratio of catalyst to oil and cavitation parameters such as geometry of orifice plate were optimized. The results obtained for a variety of oils as starting material are shown in Table 2. It can be seen from Table 2 that cavitation can be successfully applied to transesterification reactions with more than 90% yield of the product according to stoichiometry in as low as 15 min of the reaction time. The technique hence appears to be effective compared to the conventional approach, which is also evident from the comparison of different techniques based on quantitative criteria of energy efficiency, as shown in Table 3. It can be seen from Table 3 that hydrodynamic cavitation is about 40 times more efficient compared to acoustic cavitation and 160 to 400 times more efficient compared to the conventional agitation/heating/refluxing method.

### Oxidation of sulphide to sulphone with 30% H<sub>2</sub>O<sub>2</sub>

Oxidation of sulphides is the most straightforward method for synthesis of sulphones, which are important as speciality chemicals and in some cases, as agrochemicals, pharmaceuticals, lubricants, etc. Hydrogen peroxide is used as an oxidant mainly because of its effective oxygen content, produces only water by side reaction, safety in

storage and transportation. In this case, the effect of cavitation on the reaction has been studied. Various parameters affected by cavitation have been considered in this study. All the reactions have been carried out under acoustic cavitating conditions.

Methyl phenyl sulphide (thioanisole) was used as a model substrate. Different types of catalysts have been used, such as sodium tungstate and ammonium molybdate. This reaction was carried out at room temperature (28°C). The yield of sulphone was 5–6 times higher under ultrasonic irradiation compared to just agitation. With sodium tungstate as catalyst, different parameters such as molar ratio of MPS:H<sub>2</sub>O<sub>2</sub>, catalyst loading, solvent and reactant concentration have been studied. The yield of sulphone increased with increase in molar ratio, i.e. higher H<sub>2</sub>O<sub>2</sub> concentration. The yield of sulphone also increased with catalyst loading, but there was no formation of sulphone as well as sulphoxide in the absence of catalyst for 3 h. With the polar solvents, i.e. methanol and ethanol, the rate of sulphide conversion is higher and as the vapour pressure of the solvent increases, the yield also increases. This may be due to more number of cavitating species and higher exposure of reactants to cavitating conditions. In the case of non-polar solvents, the yield is higher in acetonitrile. This may be due to its miscibility with water, which forms a homogeneous phase. It is observed that the cavitating conditions are severe in water. With an increase in sulphide concentration, the yield also increases.

### Esterification of fatty acids

Methyl esters have applications in making fatty alcohols, which can be used in making plasticizers, lubricants, agricultural chemicals, detergents, emulsifiers, antioxidants, cosmetics and pharmaceutical products. Other intermediates made from methyl esters are used to make soaps, shampoos, germicides and antifoaming agents. They are also used in aluminum rolling and as a synthetic flavouring agent in foods.

The esterification of C<sub>8</sub>–C<sub>10</sub> fatty acid (FA) cut with methanol using concentrated H<sub>2</sub>SO<sub>4</sub> as catalyst has been carried out with different molar ratios of FA to methanol under hydrodynamic cavitation. The kinetic parameters of this reaction have been estimated. It is observed that the

order of the reaction is zero with respect to FA concentration. To achieve nearly complete conversion to methyl esters, the different parameters such as catalyst concentration, and molar ratio of FA to methanol have been optimized. These reactions have been carried out under ultrasonic cavitation. The kinetic parameters and energy efficiencies of these runs have also been estimated. The reaction between FA and methanol has also been carried out with superacid clay (solid, heterogeneous catalyst) as a catalyst under ultrasonic cavitation. With 2 wt% catalyst, almost complete conversion was obtained. The kinetic parameters of these reactions have been estimated.

The wax esters have potential applications as premium lubricants, parting agents and antifoaming agents as well as in cosmetics, pharmaceuticals and food additives. The reaction between FA cut (C<sub>8</sub>–C<sub>10</sub> fatty acid) and fatty alcohol (C<sub>12</sub>–C<sub>14</sub>) with conc. H<sub>2</sub>SO<sub>4</sub> as a catalyst, has been carried out using hydrodynamic cavitation reactor. The objective of this reaction was to produce wax esters. A comparison between hydrodynamic cavitation and ultrasonic cavitation has been studied for this reaction on the basis of cavitation yield. The kinetic parameters and energy efficiencies have also been estimated.

### Ultrasonic synthesis of benzaldehyde from benzyl alcohol using H<sub>2</sub>O<sub>2</sub>

An industrially important organic reaction, namely synthesis of benzaldehyde from benzyl alcohol using ultrasound has been selected for investigation as our next system. Hydrogen peroxide, being an environmentally clean oxidant, is selected as an oxidizing agent. The oxidation reaction has been carried out in the presence of a phase transfer catalyst (PTC) and a co-catalyst to form the active peroxy complex. PTC is used for facilitating the transfer of active peroxy complexes, which are present in the aqueous phase to the organic phase. The use of ultrasound is expected to enhance the rate of reaction by various mechanisms:

1. It can result into emulsions of very small sizes increasing the surface area available for the reaction.
2. Cavitation results into a faster decomposition of hydrogen peroxide into active oxygen, thereby increasing the rate of formation of active peroxy complexes.

The effect of various parameters like amount of co-catalyst, amount of catalyst, temperature, presence and absence of agitation, speed of agitation, concentration of substrate, concentration of oxidizing agent and the effect of pH were studied. The analysis was done using gas chromatography. From this detailed study of ultrasonic oxidation of benzyl alcohol with hydrogen peroxide in the presence of commercially available homogeneous catalyst and phase transfer catalyst, the following conclusions can be arrived at:

1. It is possible to oxidize benzyl alcohol to benzaldehyde at room temperature in the presence of ultrasound.
2. The rate and selectivity of benzaldehyde formation is more in the presence of ultrasound than in the presence of mechanical agitation alone.
3. The presence of PTC and catalyst is absolutely necessary. Thus ultrasound cannot replace PTC and catalyst, but it increases the effectiveness of the catalyst.
4. The physical effect of ultrasound, viz. microagitation caused due to intense cavitation collapse, is the controlling mechanism for the observed intensification of the oxidation process.
5. Less concentrated reagents are required when reactions are carried out in the presence of ultrasound than in the presence of mechanical agitation.

### Synthesis of benzonitrile

Enhancement of reaction rate by combining the beneficial effects of PTC and ultrasound has been explored by considering the transformation of benzamide by dehydration to give benzonitrile as a model system. It was found that there is a substantial reduction in the reaction time when ultrasound was coupled with PTC. The important results obtained in the study are shown in Table 4. The observed increase in the rates of reaction can be attributed to the fact that ultrasound plays a dual role in creating higher interfacial area as well as facilitating the process of interfacial transport.

### Physical processes

**Crystallization:** Ultrasonic irradiation (Dakshin horn operating at 22 kHz and rated power of 240 W) was employed during the partial crystallization of diphenyl oxide, dimethyl phenyl carbinol from its respective crude melts. The important results obtained in the study are given in Table 5.

It can be seen from Table 5 that the crystals obtained during both stages of sonication (nucleation and growth)

**Table 4.** Typical results obtained for synthesis of benzonitrile

Condition	Time (min)	Yield (%)
With PTC		
Only stirring	120	84.76
Stirring + ultrasound	5	29.43
Stirring + ultrasound	10	45.90
Stirring + ultrasound	15	52.85
Stirring + ultrasound	20	80.12
Only ultrasound	10	45.22
Only ultrasound	20	84.61
Without PTC		
Stirring + ultrasound	60	0

**Table 5.** Results for application of cavitation to crystallization operation

Crystal sample	Observed melting point (°C)	Comments
Typical results for diphenyl oxide: Observed melting point = 26.8–28°C		
Without sonication	24–28	About 55% crystals melt before 27°C. Balance 45% melts between 27 and 28°C.
Sonication during nucleation stage	25–28	About 35% crystals melt between 25 and 27°C. Balance 65% melts between 27 and 28°C.
Sonication during nucleation and crystal growth	25–28	About 15% crystals melt between 25 and 27°C. About 85% crystals melts between 27 and 28°C.
Typical results for dimethyl phenyl carbinol: Observed melting point = 35–37°C		
Without sonication	21–26	50% crystals melt between 21 and 24°C. Balance melts between 24 and 26°C.
15 s sonication	23–32	50% crystals melt between 23 and 25°C. Balance melts between 24 and 26°C.
2 min sonication	24–33	50% crystals melt between 24 and 26.5°C. Balance melts between 26.5 and 33°C.
5 min sonication	29–34.5	50% crystals melt between 29 and 31°C. Balance melts between 31 and 34.5°C.

showed considerable improvement in purity (as assessed by increase in melting point). Microscopic observation indicated that the crystals obtained with the use of ultrasound were thin, long, needle-shaped and of much smaller size (40 to 60% smaller) compared to those obtained in the absence of ultrasound. Thus ultrasound during crystallization is beneficial for improving the quality and purity of the compounds.

#### *Scope for future work*

Combination of hydrodynamic cavitation reactors and sonochemical reactors, where the cavity is generated using hydrodynamic means and, the collapse of the cavities is achieved in the sonochemical reactor. The distance between the two events (generation and collapse) will be a crucial aspect in the expected synergism and should be established with theoretical simulations and/or experimental validation for a particular application. The developed reactor should be operated in a continuous mode and needs to be tested for different reactions.

The effect of process intensifying parameters such as the presence of solid particles and bubbles should be studied in detail for small-scale reactors such as the ultrasonic horn. Its efficacy cannot be underestimated as intense cavitation is produced and it may be useful in the chemical synthesis of novel materials and also for laboratory-scale characterization of acoustic cavitation phenomenon.

#### **Concluding remarks**

Acoustic cavitation reactors generate much more intense cavitation and it appears at a first glance that one should go in for sonochemical reactors. However, it should be noted

that these reactors are associated with scale-up problems and information in a variety of fields is required for an efficient design of large-scale equipment, which is not readily available. Moreover, hydrodynamic cavitation reactors offer versatility in terms of operation and conditions similar to acoustic cavitation can be generated more efficiently. The scale-up of hydrodynamic cavitation units is much easier as knowledge regarding the hydrodynamic conditions existing downstream of the orifice is easily available in the literature or can be obtained with the help of modern CFD codes. Centrifugal pumps offer higher operating energy efficiency at larger scales of operation.

Overall, cavitation can be effectively applied for a variety of physical/chemical transformations, including chemical synthesis, biotechnology, environmental engineering, polymer engineering, etc. Also, the rates of transformation are at times, order of magnitude higher compared to the conventional approach, and energy consumption is relatively less. At this stage of development of sonochemistry/cavitation, it seems that there are some technical, economical limitations and practically no processing on an industrial scale is being carried out, though some efforts have been made with success in pilot-scale application of cavitation reactors by few research groups, including one at the Institute of Chemical Technology. More insight into intensification studies using process intensifying parameters and/or a combination of different reactor configurations/processes based on the guidelines established in the present report should help in achieving the goal of industrial-scale application. Undoubtedly, combined efforts of chemists, physicists, chemical engineers and equipment manufacturers, according to the guidelines provided here, will be required for the Chemical Process Industry to harness cavitation as a viable option for process intensification.

1. Ando, T., Sumi, S., Kawate, T., Ichihara, J. and Terukiyp, H., Sonochemical switching of reaction pathways in solid-liquid two phase reactions. *J. Chem. Soc. Chem., Commun.*, 1984, **45**, 439–440.
2. Javed, T., Mason, T. J., Phull, S. S., Baker, N. R. and Robertson, A., Influence of ultrasound on the Diels–Alder cyclization reaction: Synthesis of some hydroquinone derivatives and Ionapalene and anti-psoriatic agent. *Ultrason. Sonochem.*, 1995, **2**, S3–S4.
3. Kardos, N. and Luche, J. L., Sonochemistry of carbohydrate compounds. *Carbohydr. Res.*, 2001, **332**, 115–131.
4. Li, J., Li, L., Li, T., Li, H. and Liu, J., An efficient and convenient procedure for the synthesis of 5,5-disubstituted hydantoins under ultrasound. *Ultrason. Sonochem.*, 1996, **3**, S141–S143.
5. Lie Ken Jie, M. S. F. and Lam, C. K., Ultrasound assisted epoxidation reaction of long chain unsaturated fatty esters. *Ultrasonics Sonochem.*, 1995, **2**, S11–S14.
6. Luche, J. L., *Synthetic Organic Sonochemistry*, Plenum, New York, 1998.
7. Mason, T. J. and Lorimer, J. P., *Sonochemical Theory, Application and Uses of Ultrasound in Chemistry*, Ellis Horwood Limited, Chichester, 1998.
8. Keil, F. J. and Swamy, K. M., Reactors for sonochemical engineering – present status. *Rev. Chem. Eng.*, 1999, **15**, 85–155.
9. Shah, Y. T., Pandit, A. B. and Moholkar, V. S., *Cavitation Reaction Engineering*, Plenum, New York, 1999.
10. Thompson, L. H. and Doraiswamy, L. K., Sonochemistry: science and engineering. *Ind. Eng. Chem. Res.*, 1999, **38**, 1215–1249.
11. Gogate, P. R., Cavitation: An auxiliary technique in wastewater treatment schemes. *Adv. Environ. Res.*, 2002, **6**, 335–358.
12. Adewuyi, Y. G., Sonochemistry: environmental science and engineering applications. *Ind. Eng. Chem. Res.*, 2001, **40**, 4681–4716.
13. Save, S. S., Pandit, A. B. and Joshi, J. B., Microbial cell disruption: role of cavitation. *Chem. Eng. J.*, 1994, **55**, B67–B72.
14. Save, S. S., Pandit, A. B. and Joshi, J. B., Use of hydrodynamic cavitation for large scale cell disruption. *Chem. Eng. Res. Des. C*, 1997, **75**, 41–49.
15. Balasundaram, B. and Pandit, A. B., Selective release of invertase by hydrodynamic cavitation. *Biochem. Eng. J.*, 2001, **8**, 251–256.
16. Chivate, M. M. and Pandit, A. B., Effect of hydrodynamic and sonic cavitation on aqueous polymeric solutions. *Ind. Chem. Eng.*, 1993, **35**, 52–57.
17. Kruus, P., Lawrie, J. A. G. and O'Neill, M. L., Polymerization and de-polymerization by ultrasound. *Ultrasonics*, 1988, **26**, 352–355.
18. Price, G. J. and Smith, P. F., Ultrasonic degradation of polymer solutions. 2. The effect of temperature, ultrasound intensity and dissolved gases on polystyrene in toluene. *Polymer*, 1993, **34**, 4111–4117.
19. Thompson, D. and Sutherland, D. G., Ultrasonic insonation effect on liquid–solid extraction. *Ind. Eng. Chem.*, 1955, **47**, 1167–1169.
20. Guillen, M. D., Blanco, J., Canga, J. S. and Blanco, C. G., Study of the effectiveness of 27 organic solvents in the extraction of coal tar pitches. *Energy Fuels*, 1991, **5**, 188–192.
21. Sadeghi, K. M., Lin, J. R. and Yen, T. F., Sonochemical treatment of fossile fuels. *Energy Sources*, 1994, **16**, 439–449.
22. Oner, E., Baser, I. and Acar, K., Use of ultrasonic energy in reactive dyeing of cellulosic fabrics. *J. Soc. Dyers Colour.*, 1995, **111**, 279–281.
23. Shukla, S. R. and Mathur, M. R., Low temperature ultrasonic dyeing of silk. *J. Soc. Dyers Colour.*, 1995, **111**, 342–345.
24. Rao, S. R., Finch, J. A., Zhou, Z. and Xu, Z., Relative flotation response of zinc sulfide: mineral and precipitate. *Sep. Sci. Technol.*, 1998, **33**, 819–833.
25. Zhou, Z. A., Xu, Z., Finch, J. A., Hu, H. and Rao, S. R., Role of hydrodynamic cavitation in fine particle flotation. *Int. J. Miner. Process.*, 1997, **51**, 139–149.
26. Moser, W. R. *et al.*, The synthesis and characterization of solid state materials produced by high shear hydrodynamic cavitation. *J. Mater. Res.*, 1995, **10**, 2322–2335.
27. Zuchenko, V. A., Milchailov, B. V. and Sobolev, G. I., Use of hydrodynamic cavitation during beneficiation of quartz sands. *Sb. Tr., Vses. Nauchno-Issled. Inst. Nerudn. Stroit. Mater. Gidromekh.*, 1977, **42**, 74–80.
28. Kozyuk, O. V., Method for changing qualitative and quantitative composition of mixture of liquid hydrocarbons based on effects of cavitation. Int. Patent Appl. WO 9811983 A1, 26 March 1998, p. 28.
29. Kozyuk, O. V., Method and apparatus for producing ultra-thin emulsions and dispersions. US Patent, US 5931771 A, 3 August 1999, p. 9.
30. Cox, D. W., Dental irrigator employing hydrodynamic cavitation. US Patent Number US 5860942 A, 19 January 1999, p. 7.
31. Pandit, A. B. and Joshi, J. B., Hydrolysis of fatty oils: effect of cavitation. *Chem. Eng. Sci.*, 1993, **48**, 3440–3442.
32. Gogate, P. R., Studies in multiphase reactors, Ph D (Tech) thesis, University of Mumbai, 2002.
33. Gogate, P. R., Shirgaonkar, I. Z., Sivakumar, M., Senthilkumar, P., Vichare, N. P. and Pandit, A. B., Cavitation reactors: efficiency analysis using a model reaction. *AIChE J.*, 2001, **47**, 2526–2538.
34. Kalumuck, K. M. and Chahine, G. L., The use of cavitating jets to oxidize organic compounds in water. *J. Fluids Eng.*, 2000, **122**, 465–470.

ACKNOWLEDGEMENTS. We thank the Department of Science and Technology, New Delhi for sponsoring four research projects in the Institute of Chemical Technology, Mumbai since 1992 till date. The work presented here has been mainly due to continuing support from DST and has helped in developing an understanding of the new technology and its industrial exploitation seems to be a reality in the near future.

Received 29 November 2005; revised accepted 19 April 2006