



Towards the synthesis and characterization of metallocarbohedrenes

R. Selvan, T. Pradeep *

Regional Sophisticated Instrumentation Centre and Department of Chemistry, Indian Institute of Technology, Madras 600 036, India

Received 2 April 1999; in final form 21 June 1999

Abstract

Metallocarbohedrene, Ti_8C_{12} , has been synthesised in the solid state by resistive evaporation of Ti-covered graphite electrodes in a dynamic helium atmosphere. It forms along with other Ti-containing clusters, all of which are air sensitive. Exposure of the soot to electron-rich molecules increases air stability. The clusters are evaporated thermally yielding chemical ionization mass spectra. The ions do not fragment significantly upon collisional activation. Vacuum evaporation of the soot yields a Ti-containing film. The infrared spectrum of the soot shows characteristic peaks attributable to molecular compounds which change rapidly upon exposure to air. © 1999 Elsevier Science B.V. All rights reserved.

1. Introduction

The first metallocarbohedrene discovered, Ti_8C_{12} , was observed during the dehydrogenation reactions of hydrocarbons with evaporated titanium atoms, ions, and clusters [1]. Several other metcars (short form for metallocarbohedrenes) were observed with other metal ions giving a general formula M_8C_{12} for this class of molecules [2–9]. Mixed metcars of general formula $Ti_xM_yC_{12}$ have also been observed [10–12]. Clusters such as $M_{14}C_{13}$ and $M_{32}C_{32}$ were also observed along with metcars [13–15]. Early experiments were done using laser evaporation; subsequently several other means of metallocarbohedrene production were reported. The originally proposed, highly symmetric structure of T_h symmetry

has been predicted to be stable by various methods of theory [16,17]. Ever since discovery, structural, electronic, and magnetic properties of these clusters have been extensively investigated by theoretical methods [18–20]. Metallocarbohedrene reactivity was studied by tandem-quadrupole [21], time-of-flight [22], and ion-cyclotron resonance mass spectroscopies [23]. In spite of the extensive body of literature on various aspects of metallocarbohedrene chemistry [24], macroscopic quantities of the neutral molecule is still not available. In the early days of metcar research itself, solid state synthesis was attempted and Ti_8C_{12} was detected in the arc evaporated soot [25]. However, no further studies are available on this aspect.

Our objectives were to develop a method towards the macroscopic synthesis of metallocarbohedrenes and to characterize them by various analytical techniques. Our experiments suggest that Ti–C clusters such as M_8C_{12} form along with other clusters, are

* Corresponding author. Fax: +91-44-235-0509; e-mail: pradeep@iitm.ernet.in

stable at high temperatures and can be evaporated from the solid state in the molecular form. These materials are air sensitive and react with electron-donor molecules like their ionic analogues [26–28]. The cluster ions produced in the mass spectrometer are resistant towards fragmentation, suggesting the stability of the structure. The clusters could be purified by thermal evaporation of the soot at about 873 K and the resultant film contained Ti and C by elemental and X-ray photoelectron spectroscopic (XPS) analyses. Due to the high reactivity of the film, air exposure led to the complete degradation of the sample and an electron impact mass spectrum could not be measured.

2. Experimental method

Towards the goal outlined above, we designed and fabricated a combined thermal-arc-discharge evaporation system. Briefly, the arrangement was composed of two water-cooled copper rods using a high current of 100–200 A (20 V AC) which was passed through electrodes of choice. The arc or thermal evaporated soot was collected on water-cooled surfaces. The entire assembly was housed in a vacuum chamber of about 25 l volume which could be pumped down to 10^{-6} Torr. This part of the apparatus was similar to the familiar Krashmer–Huffman arrangement for the synthesis of fullerenes [29]. A schematic of the apparatus is shown in Fig. 1. Along with arc, additional thermal evaporation (for which a molybdenum boat was provided) and

high-voltage discharge could be applied, if necessary. The system had facilities for gas admittance and pressure measurement in the range of 10^{-6} to 1000 Torr. In the experiment, the Ti–C composite electrodes were evaporated using a current of 200 A at a helium pressure of 5 Torr. Helium (99.9% purity) was flushed through the chamber, after initial evacuation to 10^{-3} Torr. It was leaked in through a needle valve and directed to the evaporation region right above the electrodes through a 20 cm long copper tube of 3 mm diameter. The pressure was measured about 40 cm downstream with a gauge mounted on the pumping line. The evaporation was carried out under a dynamic flow of helium. We found that even small air leaks affected the results significantly and it was best to keep a continuous flow of helium. After evaporation, through another needle valve, solvents free of dissolved oxygen were introduced to stabilize the metal–carbon clusters formed in the soot. Generally acetone or pyridine at a total pressure of 10 Torr (5 Torr originally) was used. It may be necessary to warm the liquids to admit enough quantity into the chamber. Reaction between the soot and solvent introduced was allowed to continue for 5 min. Then the chamber was filled slowly with helium to release the vacuum. The soot collected was immediately pelletized in a press (13 mm diameter) under a load of 7000 pounds, and a portion was quickly subjected to various analytical methods such as mass spectrometry and atomic emission spectroscopy. Note that for infrared (IR) spectroscopy, soot without solvent stabilization was used. Soot samples with and without solvent stabilization were studied by other techniques. During all these processes, air contact was kept to a minimum. We found that the electron-impact mass spectra could be recorded if the air exposure was under 10 min. To stabilize the metcars for longer periods, the soot was dispersed in solvents such as methanol, acetone and pyridine immediately after evaporation (and after solvent exposure in the vacuum chamber). To record the X-ray photoelectron spectrum, the soot collected was evaporated thermally on to an aluminium foil under vacuum.

Key to this procedure is the preparation of the metal carbon composite electrode. We found that this influences the results obtained substantially. It has been shown earlier that Ti-rich compositions are best

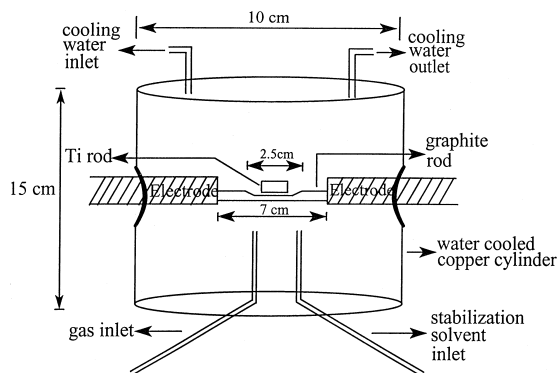

Fig. 1. Schematic of the experimental arrangement used to synthesize metcars.

for metcar production [30]. In an arc evaporation method, it is difficult to maintain the arc for long periods for Ti-filled carbon electrodes. After trying a number of methods, we arrived at the following simple procedure in which a rectangular graphite rod (length, 7 cm; width and thickness, 0.6 cm) was taken. Part of the central portion of the graphite rod was removed to give a boat-like shaped depression (see Fig. 1). A 6 mm diameter Ti rod was cut at a length of 1 cm (1.35 g) and kept in this depression. The carbon electrode thus prepared was connected between the copper electrodes and the system was evacuated. At 10^{-3} Torr, the Ti rod was melted by resistively heating the electrode which required a current of ~ 100 A. The boat was filled with Ti and excess metal formed a coating over the graphite. The electrode was allowed to cool, helium was admitted, and evaporation was started by resistively heating the electrode. Initially the central region evaporated, and the rod broke causing a gap of 1–2 mm to develop. Then a bluish arc appeared between the electrodes which was sustained for 2–3 min. By this time, about 0.5 g of the electrode was evaporated. The arc could be continued for a few more minutes by moving the electrodes closer, but, due to the possibility of air leaks through the 'O' ring seals and sensitivity of the results to air, this was avoided.

FT-IR spectra were taken by dispersing the soot in KBr matrices. A Bruker FT-IR IF66v spectrometer was used. For atomic emission spectroscopy, a ARL 3410 ICP_AES spectrometer was used. The samples were extracted with con. HNO_3 or HF. X-ray photoelectron spectra were measured with a VG ESCALAB MkII spectrometer using $\text{Mg K}\alpha$ radiation. Electron-impact mass spectra were measured with a Finnigan Mat 8230 double-sector (BE geometry, B = magnetic and E = electric sectors) mass spectrometer at 70 eV electron-impact energy. The samples were introduced through a direct inlet probe. A few milligrams of the compacted soot was inserted into the aluminum crucible with repeated pressing. The mass spectra in the range of 10–850 a.m.u. were measured. At least 100 mass spectra were measured, and the scans were averaged for better statistics at each temperature. Collision-induced dissociation spectra were measured by introducing air into the first collision cell between the ion source and magnetic sector.

3. Results and discussion

The soot after evaporation and solvent stabilization with acetone was introduced into the ion source with a direct inlet probe. The probe temperature was increased in a stepwise manner from 323 to 773 K. At 523 K, the peaks due to C_{60} were observed. At 723 K, a cluster of peaks in the range of 400–700 a.m.u. started appearing which was very clear at 773 K. The spectrum corresponding to this temperature is shown in Fig. 2. Three clusters of peaks peaking up at 425, 543 and 675 a.m.u. were observed. At each region, the different peak maxima are separated at 14 a.m.u. which is suggestive of the addition of CH_2 . These peaks cannot be attributed to any fullerene and it is also not likely that they arise from fullerene fragments. The observed masses cannot be assigned to hydrocarbons because specific hydrocarbon fragmentation pattern is not observed. A detailed examination of the isotopic distribution suggests that the peaks are not composed of carbon alone. Note particularly the peak at 529 a.m.u. This can be attributed to C_{44}H or $\text{Ti}_8\text{C}_{12}\text{H}$. Other peaks in this mass region are at 543, 557 and 571, each corresponding to an CH_2 addition. The most consistent interpretation of the peak at 529 is the chemical ionization of Ti_8C_{12} by proton addition. It appears that proton attachment is the most probable ionization pathway in all of these clusters.

In order to check the identity of the mass peak, the isotopic distribution of C_{44} and Ti_8C_{12} were computed (the isotope distribution for Ti_8C_{12} is given in the inset of Fig. 1). In this calculation, the isotopes considered for Ti are 46 (8.25%), 47 (7.44%), 48 (73.72%), 49 (5.41%) and 50 (5.18%) and for C are, 12 (98.97%), and 13 (1.03%) (abundances given in parentheses). The pattern of the peaks observed at 529 match reasonably well with that of Ti_8C_{12} . Similarly, the isotope distribution of 542 ($\text{Ti}_8\text{C}_{13}\text{H}_2$) and 556 ($\text{Ti}_8\text{C}_{14}\text{H}_4$) were also computed, which are similar to that of Ti_8C_{12} . They also match approximately well with the observed patterns. The differences with the calculated spectra can be attributed to possible H and H_2 losses in these cluster ions. What is important to mention is that the patterns cannot be attributed to that of a fullerene or a hydrocarbon. Collision-induced dissociation experiments did not show a significant differ-

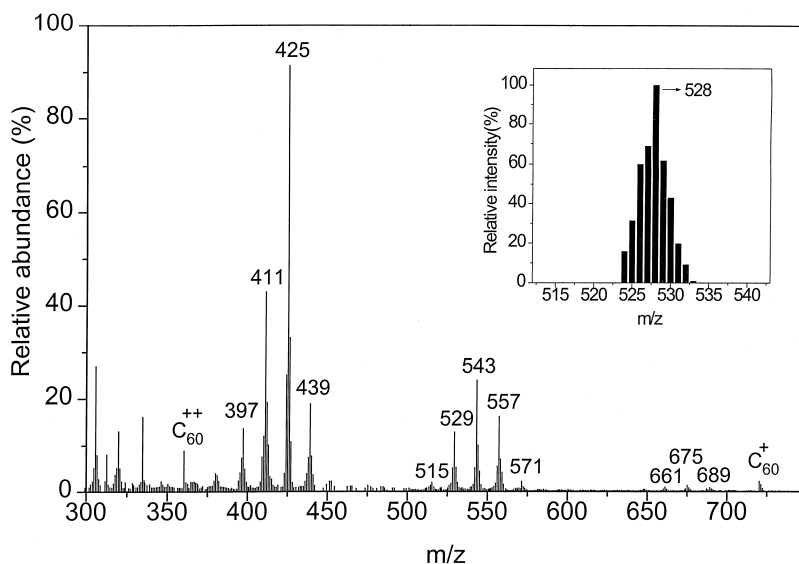

Fig. 2. An electron-impact mass spectrum of the soot at a probe temperature of 773 K clearly indicating the isotopic distribution of the metal–carbon clusters. Inset: Theoretically calculated isotope distributions for the molecular ion peaks of Ti_8C_{12} .

ence in the mass spectral pattern, suggesting the stability of the clusters. These experiments were conducted by effecting collisions with nitrogen admitted into the collision cell in the first field-free region (between the ion source and magnetic sector) at a collision energy of 3 keV. No new mass peak in the 400–850 a.m.u. region appeared as a result of collisions. The presence of Ti^+ in the mass spectrum could not be ascertained due to the high background intensity in this mass range.

The peaks at 423, 543 and 663 are spaced at 120 a.m.u. corresponding to Ti_2C_2 . Similarly peaks at 408, 528 and 648 are spaced at 120 a.m.u. again corresponding to Ti_2C_2 . The spacing between the peaks 411 and 543 corresponds to 132 a.m.u. which is probably due to Ti_2C_3 . Similarly, cluster of peaks centered around 425 and 557 are spaced at 132 a.m.u., also attributed to Ti_2C_3 . Metastable dissociation experiments by Castleman et al. [31] reveals that Ti , C_2 , C_3 and their combinations are the fragments of Ti_8C_{12} . A similar, but not exactly identical, distribution of clusters is observed in gas-phase experiments as well. For these reasons, it can be concluded that the cluster of peaks around 420, 540 and 660 a.m.u. corresponds to specific metal–carbon clusters.

Experiments were performed to react these ionic species with gases such as NH_3 introduced into the first collision cell. None of these experiments led to addition products. Part of the problem appears to be the limited sensitivity of our instrument and the high collision energies (3 keV) employed. However, it appears that the reactivity of the protonated species is considerably lower than the molecular ion.

It must be mentioned that the cluster ion intensity increased after prolonged heating. In some of our experiments, heating up to 3 h was necessary to get good intensity for the cluster peaks. It appears that the solvents introduced are bound chemically to the metcars, as physisorbed molecules would have desorbed in the long heating time employed at the elevated temperatures. In such conditions, the peak at $m/z = 543$ became the base peak of the instrument in the 200–850 a.m.u. range. We also note that C_{60} intensity has to be low to enhance the metcar peaks. It appears that experimental conditions under which more C_{60} was produced was not suitable for metcar formation.

In order to study the effect of helium pressure on the metcar peaks, the soot was produced at varying pressures ranging from 1 to 100 Torr. The best mass

spectral intensity was obtained at 10 Torr. Since the vacuum gauge was located on the pumping line, about 0.4 m away from the evaporation zone, the pressure at the region of evaporation will be significantly higher.

The soot without solvent stabilization analyzed after a day by mass spectrometry showed no sign of metcar species at the same temperature (not shown). However, peaks due to fullerenes (C_{60} and C_{70}) were observed. Weak metcar peaks were observed along with fullerenes for the soot (without solvent stabilization) analyzed immediately after preparation. We could not enhance the intensity of the metcar peaks by varying the experimental conditions. From this experiment, it is clear that neutral metcar molecules synthesized in the solid state are very unstable or air sensitive, contrary to the suggestion made earlier [25]. Due to the affinity of metcars to electron-rich donors, the soot collected (after solvent stabilization) was immediately dispersed in the same solvents. Mass spectra of this soot taken after 24 h of preparation indicated the presence of the very same clusters but with some difference in intensity distribution. Methanol, acetone and pyridine were used as solvents in these experiments. Mass spectra of the soot dispersed in pyridine showed the presence of all the clusters at a probe temperature of 773 K. Cluster

of peaks at 608 and 687 a.m.u. are attributed to the addition of one and two pyridine molecules to $Ti_8C_{12}H^+$ (Fig. 3).

The soot thus collected after evaporation was immediately transferred to another vacuum system for thermal evaporation. The system was pumped down to 10^{-6} Torr and the soot was gradually heated to a final temperature of 873 K. The temperature was monitored with a thermocouple mounted on the molybdenum boat. The vaporizable material was collected on aluminum foil kept above the boat. Evaporation was carried out for about 20 min which gave a yellowish film. A 1 cm^2 area of the foil was examined with XPS. The foil was inserted into the XPS spectrometer within about 5 min of air exposure. The Ti 2p and C 1s regions of the sample after 1 min of Ar^+ etching (2 kV, $10\ \mu A$) are shown in Fig. 4. The Ti 2p_{3/2} peak occurs at 457 eV, close to Ti(IV) [32]. The C 1s is observed at 285 eV. The O 1s region showed a feature at 529 eV, attributable to oxide. Since it is almost certain that metcars would have reacted, we do not attribute any significance to the XPS binding energies. This experiment shows that the evaporable material contains titanium and carbon and that evaporation occurs below the melting point of metallic Ti, which is also present in the soot. The foil was also digested in HF and subjected

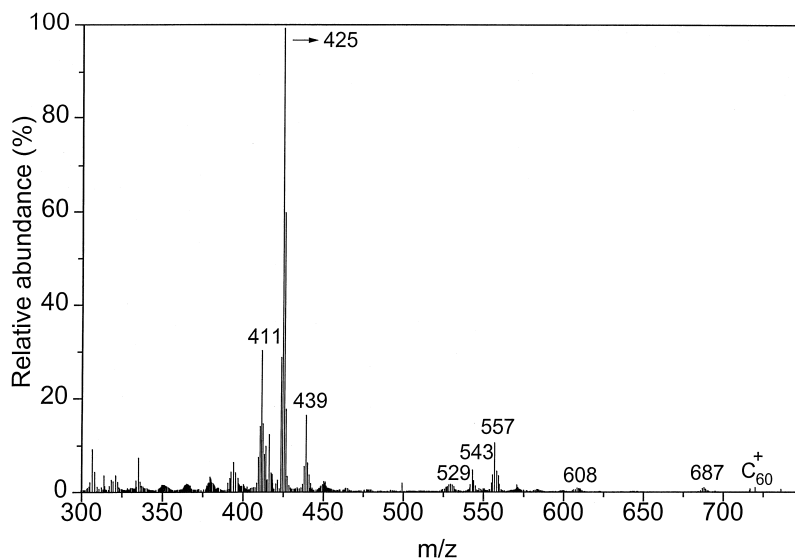

Fig. 3. Mass spectrum of the soot after treatment with pyridine at a probe temperature of 773 K.

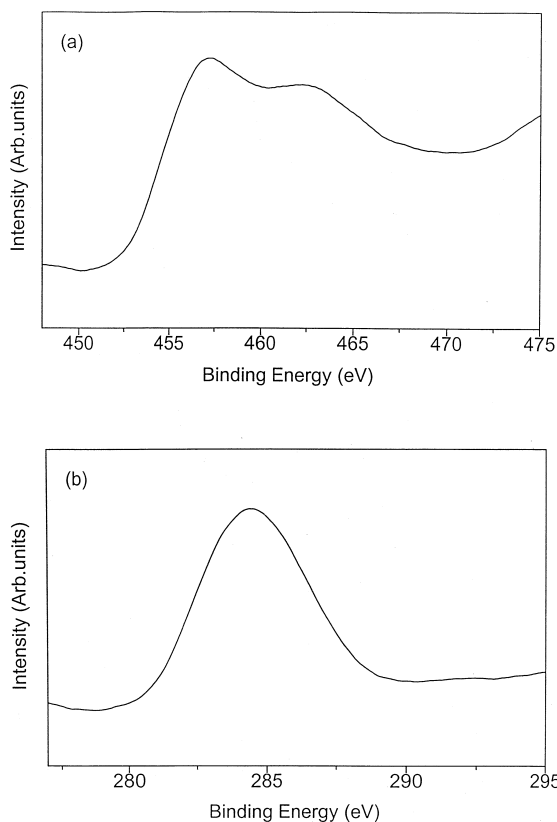

Fig. 4. X-ray photoelectron spectra of the evaporated material in the Ti 2p (a) and C 1s (b) regions.

to atomic emission spectroscopy which also indicated the presence of Ti. No quantitative analysis of Ti was done, since the nature of the chemical species after air exposure was unknown.

In order to understand the molecular nature of the clusters and to ascertain their air instability, we measured the IR spectrum of the soot at various intervals after air exposure. The soot immediately after preparation (and without solvent stabilization) was dispersed in an KBr matrix (manipulations done in air) and the spectrum was measured as a function of time. The IR spectrometer was operated in a vacuum of 10^{-2} Torr. In Fig. 5, (a), (b) and (c) correspond to the spectra within 2, 10 and 30 min after introduction into the spectrometer, respectively. As can be seen, the spectrum in the beginning has a weak feature corresponding to the methylene C–H asymmetric stretching at 2918 cm^{-1} , which gradu-

ally gains in intensity with time. In spectrum (c) the symmetric mode at 2847 cm^{-1} is also observed, indicating the formation of CH_2 groups. In the low-frequency region, the spectrum is simple with only three major structures at 1624 , 798 and 665 cm^{-1} . The three structures are broader than typical IR bands, suggesting the contribution of multiple species. The spectrum does not show intense bands due to C_{60} , in accordance with the mass spectra, but weak features at 527 and 575 cm^{-1} are seen due to its cage vibrations. Only the peak at 527 cm^{-1} is clear in all the spectra. The band at 1624 cm^{-1} is indicative of a C–C multiple bond, much higher in frequency than that of C_{60} , possibly due to C_2 -type species. In the IR spectrum of $\text{Ti}(\text{CH}_3)_4$, a band at 580 cm^{-1} is observed [33], attributed to the Ti–C bond. Corresponding bands have been observed at 557 and 532 cm^{-1} in other Ti organometallics [34]. Thus an assignment of Ti–C stretch to the band at 665 cm^{-1} is reasonable for a strained metal–carbon closed-cage structure. This assignment is also justified by the fact that this is the peak undergoing rapid change as a result of air exposure.

After a delay of 10 min, additional peaks develop in at 1457 , 1122 and 872 cm^{-1} which could be attributed to the methylene wagging, C–C stretching and methylene rocking modes, respectively. This is in agreement with the increase in intensity of the methylene C–H stretching modes. Note that all the

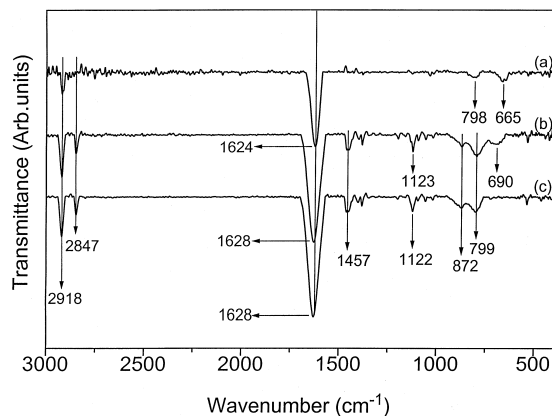

Fig. 5. IR spectra of the soot containing metal-carbon clusters in a KBr matrix. Spectra under (a) 2, (b) 10 and (c) 30 min of introduction into the spectrometer. The major frequencies are labeled.

spectra are taken with the same pellet and the acquisition parameters were the same. For the sake of comparison, the intensities have not been manipulated except the offset for clarity. The peak at 665 cm^{-1} undergoes noticeable change and, after a delay of 30 min, the peak is not observable. Although detailed information on the IR signatures of metcars are not available, the data support the formation of a highly air-sensitive molecular cluster having high symmetry. It may be added that TiO_2 (rutile) shows a broad doublet of equal intensity centred around 668 and 501 cm^{-1} . The IR spectrum of commercial TiC could not be measured as it is metallic with a room temperature resistivity in the range of $50\ \mu\Omega\cdot\text{cm}$ [35].

4. Conclusion

Molecular clusters of metcar family are amenable to synthetic procedures, and the clusters produced are thermally stable, allowing their electron-impact mass spectra to be measured. Present results are in agreement with gas-phase studies although certain other clusters are also observed. Experiments suggest high stability of the molecular ions. The molecular species are, however, highly reactive and undergo complete degradation upon exposure to air. The air stability of the clusters can be increased by dispersing the evaporated soot in electron-rich solvents. The material can be thermally evaporated in the integral form so that purification is possible. The purified material may show enhanced stability upon reaction with electron-rich donors. Although there are many more experiments which can be performed with this material, the air instability has to be solved to subject it for complete structural characterisation.

Acknowledgements

Support from the Department of Science and Technology, Government of India in the form of a research grant awarded to T.P. and Prof. P.T. Manoharan is gratefully acknowledged.

References

- [1] B.C. Guo, K.P. Kerns, A.W. Castleman Jr., *Science* 255 (1992) 1411.
- [2] B.C. Guo, S. Wei, Z. Chen, K.P. Kerns, J. Purnell, S. Buzza, A.W. Castleman Jr., *J. Chem. Phys.* 97 (1992) 5243.
- [3] J.S. Pilgrim, M.A. Duncan, *J. Am. Chem. Soc.* 115 (1993) 6958.
- [4] C.S. Yeh, S. Afzaal, S.A. Lee, Y.G. Byun, B.S. Freiser, *J. Am. Chem. Soc.* 116 (1994) 8806.
- [5] J. Purnell, S. Wei, A.W. Castleman Jr., *Chem. Phys. Lett.* 229 (1994) 105.
- [6] H.T. Deng, B.C. Guo, K.P. Kerns, A.W. Castleman Jr., *J. Phys. Chem.* 98 (1994) 13373.
- [7] B.D. May, S.F. Cartier, A.W. Castleman Jr., *Chem. Phys. Lett.* 242 (1995) 265.
- [8] W. Lu, R. Huang, J. Ding, S. Yang, *J. Chem. Phys.* 104 (1996) 6577.
- [9] F. Tast, N. Malinowski, S. Frank, M. Heinebrodt, I.M.L. Billos, T.P. Martin, *Phys. Rev. Lett.* 77 (1996) 3529.
- [10] S.F. Cartier, B.D. May, A.W. Castleman Jr., *J. Am. Chem. Soc.* 116 (1994) 5295.
- [11] H.T. Deng, B.C. Guo, K.P. Kerns, A.W. Castleman Jr., *Intern. J. Mass. Spectrom. Ion Proc.* 138 (1994) 275.
- [12] S.F. Cartier, B.D. May, A.W. Castleman Jr., *J. Phys. Chem.* 100 (1996) 8175.
- [13] J.S. Pilgrim, M.A. Duncan, *J. Am. Chem. Soc.* 115 (1993) 9724.
- [14] Y.G. Byun, C.S. Yeh, Y.C. Xu, B.S. Freiser, *J. Am. Chem. Soc.* 117 (1995) 8299.
- [15] S. Wei, B.C. Guo, J. Purnell, S. Buzza, A.W. Castleman Jr., *Science* 256 (1992) 818.
- [16] Z. Lin, M.B. Hall, *J. Am. Chem. Soc.* 114 (1992) 10054.
- [17] B.V. Reddy, S.N. Khanna, P. Jena, *Science* 258 (1992) 1640.
- [18] M. Methfessel, M. Van Schifgaarde, M. Scheffler, *Phys. Rev. Lett.* 70 (1993) 29.
- [19] I.J. Dance, *J. Chem. Soc. Chem. Commun.* (1992) 1779.
- [20] M. Rohmer, M. Benard, C. Bo, J. Poblet, *J. Phys. Chem.* 99 (1995) 16913.
- [21] B.C. Guo, S. Wei, Z. Chen, K.P. Kerns, J. Purnell, S. Buzza, A.W. Castleman Jr., *J. Chem. Phys.* 97 (1992) 5243.
- [22] J.S. Pilgrim, M.A. Duncan, *J. Am. Chem. Soc.* 115 (1993) 6958.
- [23] C.S. Yeh, S.A. Afzaal, S.A. Lee, Y.G. Byun, B.S. Freiser, *J. Am. Chem. Soc.* 116 (1994) 8806.
- [24] R. Selvan, T. Pradeep, *Curr. Sci.* 74 (1998) 666.
- [25] S.F. Cartier, Z.Y. Chen, G.J. Walder, C.R. Sleppy, A.W. Castleman Jr., *Science* 260 (1993) 195.
- [26] K.P. Kerns, B.C. Guo, H.T. Deng, A.W. Castleman Jr., *J. Am. Chem. Soc.* 117 (1995) 4026.
- [27] H.T. Deng, K.P. Kerns, A.W. Castleman Jr., *J. Am. Chem. Soc.* 118 (1996) 446.
- [28] Y.G. Byun, B.S. Freiser, *J. Am. Chem. Soc.* 118 (1996) 3681.
- [29] W. Kratschmer, L.D. Lamb, K. Fostiropoulos, D.L. Huffman, *Nature* 347 (1990) 354.

- [30] S.F. Cartier, B.D. May, A.W. Castleman Jr., *J. Phys. Chem.* 100 (1996) 8175.
- [31] S. Wei, B.C. Guo, J. Purnell, S.A. Buzza, A.W. Castleman Jr., *J. Phys. Chem.* 97 (1993) 9559.
- [32] D. Briggs, M.P. Seah, *Practical Surface Analysis*, Wiley, New York, 1983.
- [33] H.H. Eysel, H. Siebert, G. Groh, H.J. Berthold, *Spectrochim. Acta* 26A (1970) 1595.
- [34] E. Samuel, R. Ferner, M. Bigorgne, *Inorg. Chem.* 12 (1973) 881.
- [35] L.E. Toth, *Transition Metal Carbides and Nitrides*, Academic, New York, 1971.