

Transition-zone models for 2-dimensional boundary layers: A review

R NARASIMHA* and J DEY

Aerospace Engineering Department, Indian Institute of Science,
Bangalore 560012, India

*Also, National Aeronautical Laboratory, Kodihalli, Post Bag 1779,
Bangalore 560017, India

MS received 21 August 1989

Abstract. Models for the laminar–turbulent transition zone have in recent years become increasingly important, especially in technological applications where the design is driven by peak heat-transfer rates or extensive regimes of laminar or transitional flow. Models in current use can be classified into three types, namely linear-combination, algebraic and differential. The first type based on the principle of combining mean laminar and turbulent velocities, in proportions determined by the intermittency, is shown to be both successful and relatively easy to implement, especially if recent improvements in estimating turbulent spot formation rates and ideas concerning the possibility of sub-transitions within the transition zone are incorporated. Algebraic models, where the eddy viscosity is released by the intermittency, and differential models involving fairly elaborate schemes for determining the kinetic energy of turbulent fluctuations and their length scale, are found to require further development for handling flows with large pressure gradients.

Keywords. Boundary layer; laminar–turbulent transition; transition-zone modelling; intermittency.

1. Introduction

The computation, of viscous flow around a body, such as an aircraft wing or a turbomachine blade, is often critically dependent on the modelling of laminar–turbulent transition in the boundary layer on the body: Cebeci (1983) has called the representation of transition “perhaps the most important immediate modelling problem” in such flows. Generally speaking (see figure 1), the boundary layer on any surface is steady and laminar for some distance from the leading edge; as the Reynolds number for instability is exceeded it first exhibits unsteady behaviour involving two-dimensional (2-D) (‘Tollmien–Schlichting’) waves, and a three-dimensional (3-D)

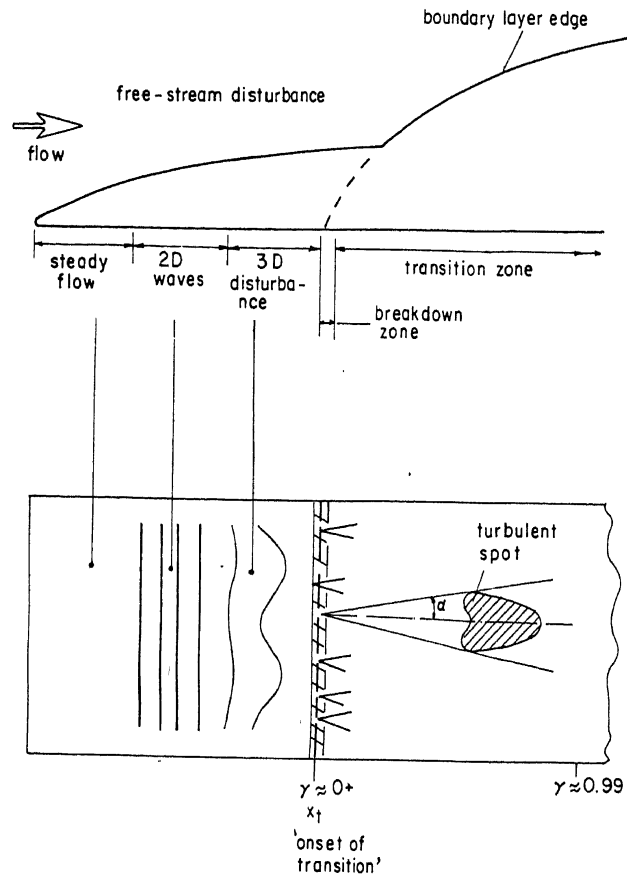

Figure 1. A schematic picture of various stages in the transition from laminar to turbulent flow in a flat plate. α and γ respectively denote the spot spread angle and intermittency. The route shown here, one among many that are possible, seems to be relevant when external disturbances are low. The instability stages may be bypassed when the environment is highly disturbed.

secondary instability further downstream. As the 3-D disturbances grow, a stage is eventually reached where the flow 'breaks down' with the appearance of intermittent turbulent fluctuations, coinciding with what we shall call the onset of transition. Finally the 'laminar' intervals disappear, and the flow attains a fully turbulent state sufficiently far downstream. As schematically shown in figure 1, there is often a substantial transition zone between the laminar and turbulent flow regimes: the overall process can be gradual, although the onset of intermittency is relatively sudden. Various experimental studies (Klebanoff *et al* 1962; Kachanov & Levchenko 1984; Saric & Thomas 1984; Suder *et al* 1988) show that there are variations in this 'route to chaos', and indeed in highly disturbed flows large chunks of the route can even be completely by-passed (Morkovin 1969); nevertheless, figure 1 represents a useful framework in a large class of boundary layer flows.

Unfortunately, the basic fluid-dynamical problems associated with many of the stages along the transition process above still remain poorly understood, although the wide recognition of the scientific and technological importance of the subject has led

to extensive research. The state of the art has been reviewed several times in the recent past from different points of view (see e.g. Morkovin 1969, Tani 1969, Narasimha 1985 and Herbert 1988). These reviews highlight the complex physical processes preceding, during and following onset of transition. Further information on experimental observations and theoretical predictions pertaining to transition are also available (e.g. Eppler & Fasel 1980; Kozlov 1985). In spite of all this effort, however, the development of a general theory of transition is "yet a utopia", as Herbert (1988) remarks in his excellent review of pre-onset flow; this is highlighted by the lack of complete agreement (already suggested above) on the precise stages in flow development leading to transition, on the order in which they occur, and on the factors that influence them.

In technological applications transition-zone modelling has if anything become increasingly more important in recent years. A turbine blade designed on the basis of fully turbulent flow from the leading edge, for instance, *underestimates* the peak heat-transfer rate experienced on the blade, as the peak is associated with the end of the transition zone (Turner 1971, see his figure 11). This in turn affects the estimated maximum values of the temperature and its gradient in operation (Krishnamoorthy 1986), leading to less realistic values for the design stress in the blade. On reusable satellite launch vehicles such as the space shuttle, which experiences wide excursions of the transition zone during flight (Gong *et al* 1984), estimates of peak heat-transfer rate exert decisive influence on the available design options (Masaki & Yakura 1969). Looking to the future, the potential rewards in the ability to manage the transition zone are yet uninvestigated; while methods for *delaying* transition onset have been widely studied, other options (e.g. *extending* the transition zone) have as yet received little attention.

The present review is chiefly concerned with modelling the intermittent transition zone. This cannot be done without suitable models for the laminar and (in particular) turbulent zones as well, but there is an extensive literature on this subject (see e.g. Rosenhead 1963; Bradshaw 1976; Launder 1989) and so it will not be separately considered here. Furthermore, this review excludes higher order models as defined by Narasimha (1985), namely those that simulate transition using the full Navier-Stokes equations. Although such simulations (e.g. Wray & Hussaini 1984; Orszag & Patera 1983; Laurien & Kleiser 1989) have reproduced many features observed in laboratory experiments and provided other information unobtainable from them (Herbert 1988), these simulations have not yet covered the transition zone as defined here.

The key variable in the transition zone is the intermittency, denoted here by γ , which may be defined as the fraction of time that the flow is turbulent. It was proposed by Emmons (1951) that intermittency arises due to the passage of randomly occurring turbulent spots in the flow. This spot picture of the transition zone was confirmed by Schubauer & Klebanoff (1955) who also provided the first quantitative data on the shape, growth and propagation of such spots. A great deal of work has since been done on the flow within and in the neighbourhood of such spots (Cantwell *et al* 1978; Wygnanski *et al* 1976; Gutmark & Blackwelder 1987; Glezer *et al* 1989 etc.). In a somewhat oversimplified view that is adequate for the present modelling purposes, the spot may be considered to have a relatively sharp reference boundary within which the flow is fully turbulent, the flow elsewhere being laminar.

In terms of the intermittency factor γ , the transition zone may be conveniently defined as beginning where γ has just departed from zero and extending to where it is

nearly unity: i.e. by the condition $0^+ < \gamma < 1^-$.

After some general remarks in the next section, various transition zone models are discussed in §§3 through 5. A brief assessment of these models followed by conclusions are given respectively in §§6 and 7.

2. General remarks

The available transition zone models can in general be classified (Narasimha 1985) into three types: (a) linear-combination, (b) algebraic, and (c) differential. There are also numerical solutions of the complete Navier–Stokes equations attempting to simulate transition, but as mentioned earlier these still do not cover the transition zone, and so are not considered further here. Apart from these models, there are also in use various data correlations (e.g. Abu-Ghannam & Shaw 1980).

In the earliest models (see e.g. Goldstein 1938), transition was assumed to occur suddenly at some station $x = X$ (say), where x denotes the streamwise distance, the fully turbulent flow for $x > X$ being so determined that the momentum thickness is continuous at X . This approach, however, is unsatisfactory, as it would yield unrealistically high values for the peak wall shear-stress and heat-transfer coefficients. To avoid this difficulty, Prandtl suggested that the emerging turbulent boundary layer should be considered to originate at the leading edge. This results in a smaller discontinuity in the wall stress, but causes a larger one in the boundary layer thickness (Narasimha 1985). However, these ‘instantaneous-transition’ models are inadequate especially when the transition zone occupies a significant fraction of the body surface: numerous measurements on turbomachinery blades (Turner 1971; Brown & Burton 1978; Priddy & Bayley 1985; Krishnamoorthy 1986) have shown that this does happen often, the proportion being sometimes as high as 80%. In situations where the design is driven by the maximum heat-transfer rate (e.g. the space shuttle, Masaki & Yakura 1969) estimates that are too conservative involve a heavy penalty.

The ‘sudden transition’ model is therefore of little use, except possibly in adverse pressure gradients producing a separation bubble, where the transition zone can be very short (see e.g. Walker & Gostelow 1989). Various more detailed transition zone models have been proposed over the years; these are listed in table 1, with brief remarks on the salient features of each of them.

Table 1. A brief summary of transition-zone models.

Authors	Type	Remarks
Dhawan & Narasimha (1958)	Linear combination	Combination of laminar and turbulent velocities in proportions determined by the intermittency. Requires onset (x_t), extent of zone, model for fully turbulent flow. Constant pressure. Simple
Chen & Thyson (1971)	Linear combination	For axisymmetric flows. Special intermittency model, correlation for length. Limited validation
Lakshminarayana (1976)	Linear combination	As in Dhawan & Narasimha. Integral method for axisymmetric body and high speed flows
Arnal (1986)	Linear combination	Integral method. Linear combination for shape factor and skin-friction. Intermittency in terms of momentum thickness, not related to spot theory

(continued)

Table I. (continued)

Authors	Type	Remarks
Fraser & Milne (1986)	Linear combination	Velocity and skin-friction as in Dhawan & Narasimha. Intermittency is error-function. Extent in terms of standard deviation of intermittency. Integral method
Fraser <i>et al</i> (1988)	Linear combination	Extension of Fraser & Milne, but different correlation for zone-length. Good agreement with data on turbine blades
Dey & Narasimha (1989a)	Linear combination	Extension of Dhawan & Narasimha. Extent from new spot formation rate parameter. Integral method. High favourable pressure gradient data also predicted
Harris (1971)	Algebraic	Eddy viscosity and thermal diffusivity. Intermittency of Narasimha. Requires extent. Compressible plane and axisymmetric flows
Kuhn (1971)	Algebraic	Eddy viscosity. Method of integral relations for high speed flows. Intermittency distribution of Narasimha (1957)
Adams (1972)	Algebraic	Eddy viscosity. Intermittency distribution of Narasimha (1957); takes extent $=x_t/2.96$
Cebeci & Smith (1974)	Algebraic	Eddy viscosity. Intermittency distribution of Chen & Thyson (1971). Predicts x_t
Gaugler (1985)	Algebraic	Eddy viscosity, based on STAN5 code. Intermittency distribution of Abu-Ghannam & Shaw (1980). Onset and extent adjusted to obtain agreement with experimental data
Michel <i>et al</i> (1985)	Algebraic	Intermittency in terms of momentum thickness, exceeds 1 for ensuring agreement with data
Krishnamoorthy (1986)	Algebraic	Extension of Patankar-Spalding (1970) for predicting heat transfer rates on turbine blades and nozzle guide vanes. Intermittency distribution of Narasimha (1957). x_t and extent from measurements. Effect of large free-stream turbulence by addition to eddy viscosity, shows good agreement with experiments
Krishnamoorthy <i>et al</i> (1987)	Algebraic	Extension of Krishnamoorthy (1986) with onset momentum thickness Reynolds number = 160. Dhawan-Narasimha correlation for extent extended to pressure gradients
McDonald & Fish (1973)	Differential	Integral form of a turbulent kinetic energy equation. Source terms in governing equation through which free-stream turbulence triggers transition
Blair & Werle (1980, 1981)	Differential	Extension of McDonald & Fish (1973) and McDonald & Kreskovsky (1974). Zero pressure gradient heat transfer generally predicted well (but not for the flow at free-stream turbulence level = 0.25), less satisfactory for pressure gradient flows
Wilcox (1981)	Differential	Stability related closure model. Tested for constant-pressure flows at low free-stream turbulence levels
Arad <i>et al</i> (1982, 1983)	Differential	Modified two-equation model of Ng (1971). Requires adjustment of numerical constants
Vancoillie (1984)	Differential	Based on $K-\varepsilon$ model. Conditional averages of all quantities require intermittency, which is taken as that of Narasimha (1957). Good agreement with data considered
Wang <i>et al</i> (1985)	Differential	Based on $K-\varepsilon$ model; sensitive to boundary conditions for K, ε for airfoil cascade. Discrepancy noted in transitional and turbulent regions on suction surfaces of turbine blades
Krishnamoorthy <i>et al</i> (1987)	Differential	$K-\varepsilon$ model of Jones & Launder with change in a constant. Tested for nozzle guide vane data. Underpredictions near trailing edge attributed to separation

3. Linear combination models

This class of models in general takes the mean flow during transition as a linear combination, in the proportions $(1 - \gamma): \gamma$, of the mean flow in the laminar and turbulent boundary layers respectively. **All** models of this class require methods for carrying out the following tasks:

- (a) calculation of the laminar boundary layer,
- (b) estimation of mean flow parameters in a fully turbulent boundary layer starting from an arbitrary station in the flow,
- (c) prediction of the location of the onset of transition, and
- (d) the intermittency distribution in the transition zone.

The methods differ only in the manner in which these tasks are performed, as we shall see below.

3.1 Dhawan & Narasimha (1958)

This was the earliest transition zone model that could make reasonable predictions of **all** parameters (including mean velocity profile) in the transition zone, provided the onset location was given. The model considered only constant-pressure flows. The laminar boundary layer is considered to originate from the stagnation point, and the turbulent boundary layer from an onset station further downstream, to be denoted here by x_* . The mean velocity and skin friction coefficient are respectively taken as

$$u = (1 - \gamma)u_L + \gamma u_T, \quad (1)$$

$$C_f = (1 - \gamma)C_{fL} + \gamma C_{fT}. \quad (2)$$

Here (and in what follows) suffixes L and T denote values in the laminar and turbulent boundary layers, each starting from its respective origin, and the velocity is non-dimensionalised with respect to the free-stream velocity $U(x)$. The fully turbulent flow was calculated from a prescribed origin using well-known similarity laws (e.g. Coles 1968).

The intermittency was taken to be the universal distribution (Narasimha 1957),

$$\gamma = 1 - \exp(-0.41 \xi^2), \quad \xi = (x - x_*)/\lambda, \quad (3)$$

where

$$\lambda = x(\gamma = 0.75) - x(\gamma = 0.25) \quad (4)$$

is a measure of the extent of the transition zone. There was no attempt to *predict* x_* , but an effective method of determining it from experimental data proceeded as follows (Narasimha 1957). A consequence of (3) is that the quantity

$$F(\gamma) = [-\ln(1 - \gamma)]^{1/2}$$

varies linearly with x . The value of x_* may therefore be found by plotting $F(\gamma)$ vs x , and extrapolating a best straight-line fit for the bulk of the data to the point $F(\gamma) = 0$. This procedure is particularly desirable because very low and very high values of γ are **not** too easily measured, as they are sensitive to the discrimination technique adopted (Narasimha *et al* 1984), and furthermore because (3) may not be strictly valid near x_* , especially at low Reynolds numbers, as it assumes that *all* breakdowns occur at x_* ,

whereas in actual fact they do so in a narrow belt around it. Thus it is preferable to give greater weight to measurements of moderately high values of the intermittency. Following Walker & Gostelow (1989) we shall call the procedure described above as analysis on the ' $F(\gamma), t$ ' basis. The great importance of x_t so determined is that it also corresponds to the origin of the emerging turbulent boundary layer. Although γ need not be strictly zero at this x_t , it is always small.

It was shown by extensive comparison with experiment that the linear combinations (1) and (2) led to an excellent description of the transition zone in constant pressure flows; in particular, mean velocity profiles, skin friction, and all integral parameters of the boundary layer were shown to be well-predicted.

Dhawan & Narasimha (1958) further proposed that the transition zone length parameter λ was given by the rough correlation

$$\text{Re}_\lambda = 5 \text{Re}_{x_t}^{0.8}, \quad (5)$$

where Re_λ and Re_{x_t} denote the Reynolds numbers based on λ and x_t respectively. (Hereafter, the relevant Reynolds number will always be denoted following this notation; for example, Re_{x_b} will correspond to x_b .) The data collected by Dhawan & Narasimha (1958) showed considerable scatter in part because the definitions used for onset and extent were not uniform. (The use of a variety of transition detection techniques has led to a corresponding variety of definitions of the beginning of transition; some examples will be cited later. Unless otherwise stated, however, we will always use x_t here to denote the onset of transition.)

From (3), Dhawan & Narasimha (1958) also drew the interesting conclusion that the extent of the transition zone varies as the inverse square root of the breakdown rate, so that

$$\dot{n} = n\sigma v^2/U^3 = 0.41 \text{Re}_\lambda^{-2} = 0.016 \text{Re}_{x_t}^{-1.6}, \quad (6)$$

where n denotes the number of spots born per unit time and spanwise length at the point of breakdown, σ is a non-dimensional spot propagation parameter and v is the kinematic viscosity.

Various extensions and improvements of this model are seen in the work of Chen & Thyson (1971), Lakshminarayana (1976), Fraser and his co-workers (Fraser & Milne 1986; Fraser *et al* 1988) and Dey & Narasimha (1989a).

3.2 Chen & Thyson (1971)

This model is formulated for an axisymmetric body, on which the γ -distribution is taken as

$$\gamma = 1 - \exp \left\{ -nr(x_b) \left[\int_{x_b}^x r^{-1} ds \right] \left[\int_{x_b}^x U^{-1} ds \right] \right\}, \quad (7)$$

with a characteristic length of the transition zone defined by

$$\lambda_{CT} = x(\gamma = 0.95) - x(\gamma = 0). \quad (8)$$

In (7), r and x denote the body radius from the axis of symmetry and streamwise distance along the surface respectively, and x_b denotes the location of the onset of transition ($\gamma = 0^+$). The spot formation rate is assumed (at zero Mach number) to be

given by the relation

$$\hat{n} = \text{Re}_{x_b}^{-1.34}/1200;$$

note the similarity between this proposal and (6) above. Chen & Thyson estimate the heat transfer coefficients by a relation similar to (2).

The intermittency distribution (7) is open to the criticism that it does not yield the correct one-dimensional distribution in axisymmetric flows (Narasimha 1985), and does not agree with measurements in pressure gradients (Narasimha *et al* 1984).

3.3 *Lakshminarayana (1976)*

In this method, devised for compressible flow over blunt bodies, laminar and turbulent parameters are estimated respectively using the methods of Lees (1956) and Spence (1961). An extension of the Dhawan–Narasimha model is used for heat transfer in the transition zone.

3.4 *Arnal (1986)*

Here integral methods are used for calculating laminar and turbulent parameters. Arnal predicts C_f using (2), and the shape parameter $H \equiv \delta^*/\theta$, where δ^* and θ respectively denote the displacement and momentum thicknesses, also by a similar linear combination

$$H = (1 - \gamma)H_L + \gamma H_T. \quad (9)$$

The intermittency distribution is taken to be

$$\gamma = 1 - \exp[-4.5(\theta/\theta_t - 1)] \quad (10)$$

where θ_t denotes the value of θ at x_t .

There are some difficulties with this approach. First of all, the prescription of the intermittency in terms of θ has not only no basis in the spot theory of transition, but is inconvenient, as θ is itself a function of the intermittency – in fact a rather complex one. This is easily seen from the expression

$$\begin{aligned} \theta &= \int_0^\delta u(1-u)dy \\ &= \gamma(1-\gamma) \int_0^\delta [u_L(1-u_T) + u_T(1-u_L)]dy + (1-\gamma)^2\theta_L + \gamma^2\theta_T, \end{aligned} \quad (11)$$

(where δ denotes the boundary layer thickness), which follows from the linear-combination principle (1) for the velocity. If this principle is accepted – as it must be to use (2) for the skin friction – then it is necessary to show that a prescription of γ as a function of θ is consistent with the principle. Relation (9) is certainly not so consistent: unlike the displacement thickness, and as (11) shows, the momentum thickness is not a linear functional of the velocity profile and hence cannot be obtained from a linear combination of the type (2). Therefore H cannot be, either. For the prediction of x_t , which appears to be taken to correspond to the minimum in the skin friction distribution, a stability-related correlation is used. Arnal computes solutions of his model for the flows measured by him and his coworkers (Michel *et al* 1985), and finds good agreement.

Arnal and his coworkers (e.g. Michel *et al* 1985) assume that the γ -distribution is independent of pressure gradient, but this assumption is valid only for weak pressure gradients as shown by the experiments of Narasimha *et al* (1984). The model therefore does not allow for the occurrence of the sub-transitions observed on flows subjected to high pressure gradients, which we shall discuss below in §3.6.

3.5 Fraser & Milne (1986)

This is another integral method in which laminar and turbulent parameters are estimated using respectively the Thwaites (1949) method and the lag-entrainment scheme of Green *et al* (1973); the required velocity profiles are taken from Pohlhausen's (1921) quartic for u_L and a power-law for u_T , with non-constant power law index. The log-plus-wake profile (Coles 1968) was not used as the integral parameters in the transition zone were found by Fraser & Milne to be predicted better by the power-law profile. For the prediction of onset, these authors utilise the correlation of Abu-Ghannam & Shaw (1980). The intermittency distribution is based on a Schubauer-Klebanoff (1955) type error-function fit in terms of the parameter $\eta = (x - \bar{x})/\sigma_s$, where $\bar{x} = x(\gamma = 0.5)$ and σ_s is the standard deviation, but is approximated by the polynomial

$$\gamma = 0.5[1 + (0.0165|\eta|^4 - 0.073|\eta|^3 - 0.094|\eta|^2 + 0.8273|\eta|)\eta/|\eta|]. \quad (12)$$

Fraser & Milne (1986) also assume that the intermittency distribution is independent of pressure gradient. The extent in terms of the standard deviation is correlated to the free-stream turbulence by the relation

$$\begin{aligned} \text{Re}_{\sigma_s} &= [8.5 - 2.9(q/10)^{0.15}] \text{Re}_{\theta_t}^g \\ g &= 1.635 + 0.00367(\text{Re}_{\theta_t}/100) - 0.00129(\text{Re}_{\theta_t}/100)^2, \end{aligned} \quad (13)$$

where q denotes the free-stream turbulence intensity (as percentage of the mean velocity). The correlation (13) is preferred by Fraser & Milne as it shows less scatter than another considered by them, namely

$$\text{Re}_{\sigma_s} = 7.13(\text{Re}_{\theta_t})^{1.6}, \quad (14)$$

which is obtained by relating σ_s to λ and using (5).

Fraser & Milne (1986) start their turbulent calculation from the station x ($y = 0.01$) taking the initial value of θ_T (required in the method of Green *et al* 1973) as $0.2\theta_L$. They also mention that the turbulent calculation started at a downstream station corresponding to $\gamma = 0.1$ gives "optimal agreement with data". The variation of C_f , however, is found to require smoothing, which is done using a special correlation. Predictions of C_x , H and θ agree well with the pressure gradient data of Abu-Ghannam & Shaw (1980) and with constant-pressure data from various sources including their own.

3.6 Fraser *et al* (1988)

This is an extension of Fraser & Milne's (1986) method. The onset location is taken by Fraser *et al* to correspond to $\gamma = 0.01$. Fraser *et al* also measured intermittency distributions in both zero and non-zero pressure gradients, and found the results to be

independent of pressure gradient, a fact attributed by them to the low pressure gradients in their experiments. The Abu-Ghannam-Shaw model was found to depart considerably from the intermittency data measured by Fraser *et al* (1988). For the extent (in terms of the standard deviation), the correlation (13) is abandoned in favour of a new correlation,

$$\begin{aligned} Re_{ss} &= Re_{ss0} [1 + 170 L_t^{1.4} \exp\{-(1 + q^{3.5})^{0.5}\}]^{-1}, \\ Re_{ss0} &= [270 - \{250 q^{3.5} (1 + q^{3.5})^{-1}\}] \times 10^3, \end{aligned} \tag{15}$$

where L_t is the value of the pressure gradient parameter $L (= \theta_L^2 U'/\nu; U' = dU/dx)$ at x_t , and Re_{ss0} corresponds to $L = 0$. The correlation (15), however, is restricted to zero and adverse pressure gradients ($0 \leq -L_t \leq 0.4$). Comparison with measurements on the suction surface of a turbine blade, reported by Sharma *et al* (1982), shows good overall agreement (figure 2).

3.7 Dey & Narasimha (1989a)

The integral method proposed recently by these authors has a structure which is most easily understood by examining the block diagram (figure 3) that shows the modular structure of the comprehensive boundary layer package (called TRANZ 2) developed by them. The LAMFLO module does laminar calculations based on the Thwaites (1949) method as extended and modified (Dey & Narasimha 1989b) to handle large pressure gradients better (in the range $-0.082 \leq L \leq 0.4$ compared to $-0.082 \leq L \leq 0.25$ of Thwaites) and provide the additional parameters (like δ_L) required in the model; u_L (from LAMVEL) is a quartic profile similar to that of Pohlhausen (1921). The module TURFLO estimates turbulent parameters using the lag-entrainment scheme of Green

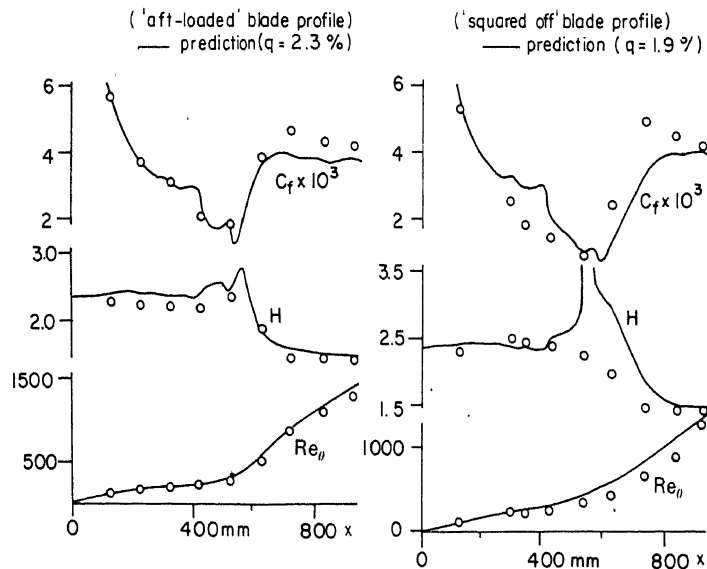

Figure 2. Comparison by Fraser *et al* (1988) of their predictions (full lines) for the flow measured by Sharma *et al* (1982; open symbols) on the suction surface of turbine blading. The prediction is made by a linear-combination type integral method. Re_θ denotes the Reynolds number based on the momentum thickness.

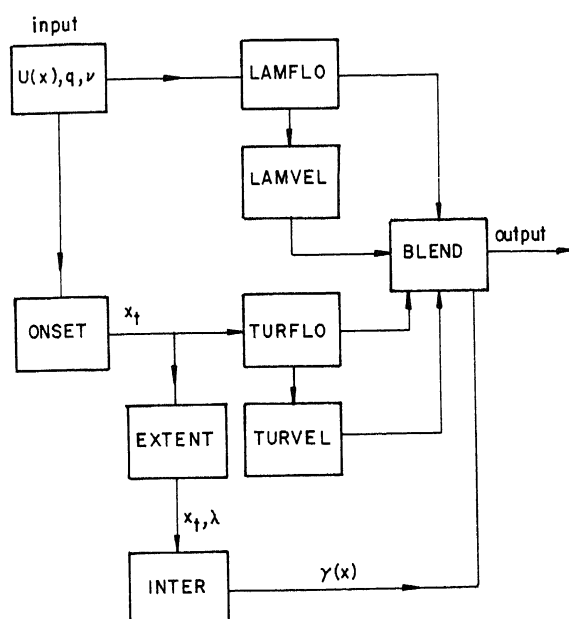

Figure 3. Schematic structure of the TRANZ2 package.

et al (1973); u_r is obtained from TURVEL using the log-plus-wake profile. The ONSET module provides the origin of the emerging turbulent boundary layer utilising the correlation developed by Govindarajan & Narasimha (1989). The extent of transition (from the module EXTENT) is derived from values of a new non-dimensional spot formation rate parameter N (Narasimha 1985) defined below. The intermittency distribution (from the origin of the turbulent layer) is obtained from the module INTER. The module BLEND provides the transitional parameters u , C_f , and θ respectively from (1), (2) and (11), and δ^* , H and δ respectively from

$$\delta^* = (1 - \gamma)\delta_L^* + \gamma\delta_T^*, \quad H = \delta^*/\theta, \quad (16)$$

and

$$\delta = \delta_L, \quad \text{if } \delta_L > \delta_T.$$

Various computational domains adopted in this model are shown in figure 4. Predictions of C_f , H , θ , δ^* and δ agree well with the strong favourable pressure gradient data of Blair & Werle (1981) and Narasimha *et al* (1984), and with the constant-pressure data of Schubauer & Klebanoff (1955), Abu-Ghannam & Shaw (1980), Narasimha *et al* (1984) and Blair & Werle (1980).

The onset prediction scheme of Govindarajan & Narasimha (1989) utilised in the ONSET module takes into account the residual non-turbulent disturbances in a facility when predictions are made for test results. The correlation proposed by these authors is

$$\begin{aligned} \text{Re}_{\theta_t} &= \text{Re}_{\theta_{t0}} [1 + 0.15 \{ \exp(-q) + 2 \} \{ 1 - \exp(-60L) \}], \\ \text{Re}_{\theta_{t0}} &= 100 + 310/[q^2 + q_0^2]^{1/2}. \end{aligned} \quad (17)$$

Here Re_{θ_t} denotes the Reynolds number based on the momentum thickness at the

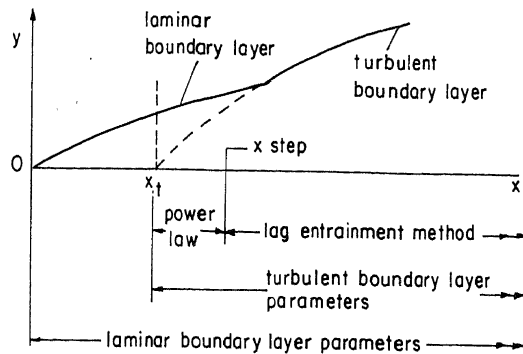

Figure 4. Various computational domains adopted in the linear-combination type integral model of Dey & Narasimha (1989a).

origin of the turbulent layer, Re_{θ_0} is its value at $L=0$, and q_0 is the equivalent free-stream turbulence for the residual disturbances associated with a given facility.

The non-dimensional spot formation rate, which provides information on the extent of the transition zone, is derived from the physically appealing consideration that the breakdown rate scales primarily with the local boundary layer thickness δ and the viscosity ν , suggesting that the appropriate non-dimensional spot formation rate is $N = n\sigma\theta_i^3/\nu$, where θ is preferred to δ as it is more precisely defined. In constant-pressure flow, this scaling is suggested by the γ -distribution

$$\gamma = 1 - \exp[-n\sigma(x - x_t)^2/U]$$

(which is the original relation on the basis of which the non-dimensional distribution (3) is derived), and the correlation (Narasimha 1985)

$$Re_\lambda = C Re_{xt}^{0.75}, \quad (18)$$

(where C is a constant), with the use of the Blasius relation for the boundary layer thickness as a function of x . The correlation (18) fits the data compiled by Dhawan & Narasimha (1958) as well as the correlation (5) does.

The use of the parameter N has already permitted the study of the effect on the transition-zone length of free-stream turbulence (Narasimha 1985; Narasimha & Dey 1985) and pressure gradient (Dey & Narasimha 1989c; Gostelow 1989) in a more meaningful way than before. Thus, systematic variations have been revealed within the data which earlier had just been interpreted as scatter (e.g. Dhawan & Narasimha 1958, and others following it, such as Harris 1971 and Adams 1972). In constant-pressure flows, N is found to decrease with increasing q to a constant value of about 0.7×10^{-3} in transition driven by free-stream turbulence (Narasimha 1985). The increase in N at low q may at first appear paradoxical, but then θ_i drops rapidly with increasing q , and the actual spot formation rate goes up. This behaviour of N with q had not been discovered using empirical relations like (5).

The intermittency distribution (3), derived for constant-pressure flows, appears to be valid in mild pressure gradients also, the limit being $L < 0.06$ according to Narasimha & Dey (1983). In stronger pressure gradients, Narasimha *et al* (1984) have shown that an important parameter is the location of the pressure gradient relative to the onset. For example, a favourable pressure gradient applied near the onset tends to lengthen the transition zone: furthermore, the γ -distribution does not follow the constant-pressure law (3), and $F(\gamma)$ shows a segmented linear variation (see figure 5). The kink in this figure may be thought of as indicating a 'sub-transition' (Narasimha

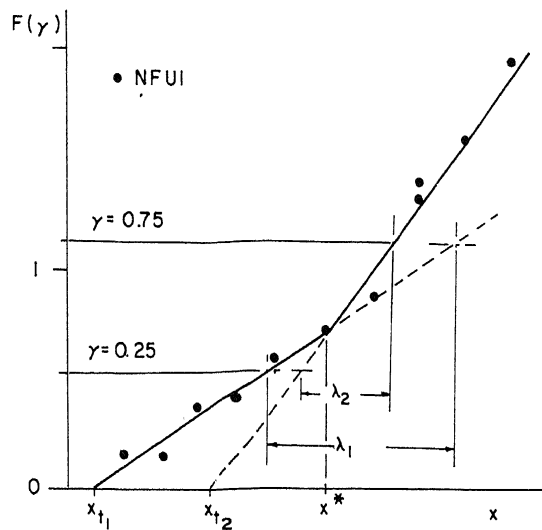

Figure 5. Segmented linear variation (full lines) of $F(\gamma)$ in favourable pressure gradient. Filled symbols are experimental points from flow NFUI (Narasimha *et al* 1984).

1985), caused by a relatively sudden change in the nature of the flow from a subcritical to a supercritical state. In such cases (3) holds in segments, and is so used in the model of Dey & Narasimha; for the favourable-gradient flows examined by these authors, the station x_{t2} (see figure 5), determined by extrapolating to zero the downstream (supercritical) part of the $F(\gamma)$ curve, is found to be the effective origin of the turbulent layer; laminar calculations are adequate upstream of x_{t2} . It is interesting that, based entirely on calculations from this model, Dey & Narasimha (1989a) inferred the presence of sub-transitions in the data of Blair & Werle (1981); direct confirmation of their inference has since become available with the measurements of intermittency (Blair 1988), which shows kinks in the $F(\gamma)$ plots of precisely the kind seen in figure 5.

The value of using N as the appropriate parameter for specifying the spot formation rate has been recently confirmed by the work of Gostelow (1989). He has found that while earlier methods led to double-valued parameters, the consistent use of the $F(\gamma)$, t basis leads to a well-defined, unique value of N at each value of the pressure gradient parameter L at the onset location (figure 6).

4. Algebraic models

These models directly tackle the time-averaged equations of motion with an appropriate algebraic model for the Reynolds stress, which is gradually turned on in the transition zone in proportions determined by the intermittency. For example, an effective total diffusivity (including viscosity) in the flow may be taken to be

$$\bar{v} = \nu + \gamma \nu_T, \quad (19)$$

where ν_T is the eddy diffusivity. The transitional intermittency in (19) has to be obtained separately; implicitly, this requires information on onset location and transition-zone length.

Though the use of an eddy viscosity in certain flows has been justified by Townsend (1956) based on considerations of large-eddy equilibrium, the concept suffers from the

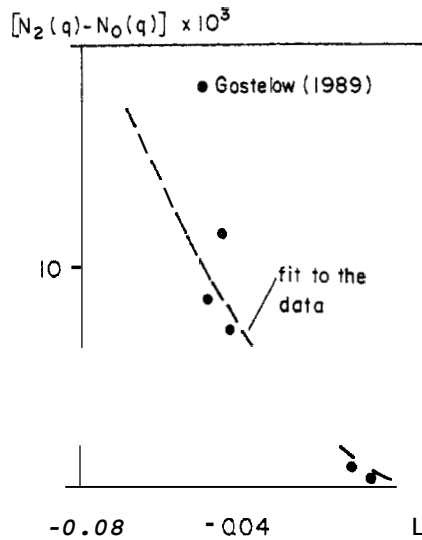

Figure 6. Variation of the quantity $[N_2(q) - N_0(q)]$ with the pressure gradient parameter L in adverse pressure gradients, N_2 denotes the non-dimensional spot formation rate in pressure gradient, and N_0 is the value of N_2 at the same free-stream turbulence level (4) but without pressure gradient; $N_0(q)$ is taken as 0.7×10^{-3} .

well-known limitations of all gradient-transport theories (i.e. Batchelor 1950; Narasimha 1989). Nevertheless, when properly used, an eddy viscosity can provide useful estimates of certain gross boundary layer characteristics.

4.1 Harris (1971)

This model was formulated for compressible plane or axisymmetric flow using mass-averaged velocities and the intermittency model of Narasimha (1957). To determine x_t , Harris used a critical vorticity Reynolds number as proposed by Rouse (1945) as well as various empirical correlations. The transition zone length was often taken from experiments, but it was suggested that when this was not possible, one may take

$$x_{\max} - x_{\min} \equiv l = x_{\min}, \tag{20}$$

where x_{\min} and x_{\max} denote the streamwise locations corresponding to the minimum and maximum in the surface-Pitot measurements. [It may be noted that while extrema in surface parameters (whether Pitot pressure, skin-friction or wall heat-transfer) have been widely used (e.g. Schubauer & Skramstad 1948; Coles 1954) to mark the limits of the transition zone, different indicators do not necessarily coincide. For example, x_{\min} does not correspond to the onset location x_t mentioned earlier, and x_t is upstream of x_{\min} (Narasimha 1958; Owen 1970; Suder *et al* 1988). The tentative conversion factors (Narasimha & Dey 1985)

$$x_t \approx x_{\min} - 0.26(x_{\max} - x_{\min}), \quad \lambda = 0.4(x_{\max} - x_{\min}), \tag{21}$$

have been found to be useful for making consistent comparisons of data from intermittency distributions and surface parameter extrema.]

4.2 Kuhn (1971)

Kuhn's prediction scheme for high speed flows is based on the method of integral relations, and the intermittency is taken as

$$\gamma = 1 - \exp[-\lambda_k(x - x_t)^2]. \tag{22}$$

The parameter λ_k is related by Kuhn to the transition zone length l defined in (20),

$$\lambda_k = 2.66/l^2, \quad (23)$$

with x_{\max} taken to correspond to $\gamma = 0.95$. It is clear that (22) and (23) (wrongly attributed by Kuhn to Emmons 1951) are really (3) in disguise. Analysing various high speed data, Kuhn also proposes the correlation

$$\text{Re}_{lk} = (\bar{A} + \bar{B}M)\text{Re}_{xt}^f, \quad (24)$$

where \bar{A} , \bar{B} and f are constants, and M denotes the Mach number; for different flow geometries, various values have been proposed for these constants. Once again (24) is an extension of (5) to include Mach number effects. It is therefore no surprise that Kuhn finds good agreement with the low speed constant-pressure data of Schubauer & Klebanoff (1955), and his value of $\lambda_k = 0.838 \text{ ft}^{-2}$ is equivalent to taking $\lambda = 0.7 \text{ ft}$ in (3), which is virtually the same as that used by Narasimha (1957).

Kuhn's high speed flow analyses have produced some interesting results. He finds that his model is comparable to that of Harris (1970) (and presumably therefore also of Harris 1971), who uses the γ -distribution (3). Kuhn also finds that his predictions [with (22)] show good agreement with the measurements made by Zakkay *et al* (1966) on a cone-flare geometry at $M = 8$; transition in this flow occurs in a region of adverse pressure gradient, and x_t and λ_k are inferred by him from the measured heat transfer distribution. Implicit in these results is the effectiveness of the hypothesis of concentrated breakdown. Kuhn, however, finds that his scheme could not predict the flat plate data obtained at the Langley Research Center at $M = 6.18$, as well as the data of Fischer (1970) on a cone of 10° half-angle at $M = 5.5$; intermittency distributions inferred by him by matching predictions with the experimental data differed from (22) as shown in figure 7 as an example. He proceeded to conclude that "the intermittency distributions of hypersonic boundary layers do not always fit the simple probability distribution of Emmons as used by Dhawan and Narasimha". This conclusion is unjustified for the following reasons. First it is not based on any intermittency measurements. The detailed measurements of γ by Owen & Horstman (1972) on a cone of 5° half-angle at a Mach number of 7.4, on the other hand, show good agreement with (3). Second, an inappropriate choice of the parameters x_t and λ_k in (22) [and therefore of x_t and λ in (3)] will result in a misleading intermittency distribution (Dey 1988); as Kuhn does not report the values of these parameters used by him, a comparison similar to that carried out above for the low-speed data of Schubauer & Klebanoff (1955) remains difficult here.

4.3 Adams (1972)

This model for hypersonic flows utilises the intermittency distribution (3) and a mixing-length model with a Van Driest damping factor (see Bradshaw 1976) for the eddy viscosity. The transition zone length proposed by Adams is equivalent to putting $\lambda = x_t/2.96$ (Narasimha 1985).

4.4 Cebeci & Smith (1974)

This method uses a more elaborate model for the eddy viscosity, allowing for low Reynolds numbers and possible mass transfer at the surface. The intermittency distribution adopted is the Chen-Thyson model (7). Comparisons with the

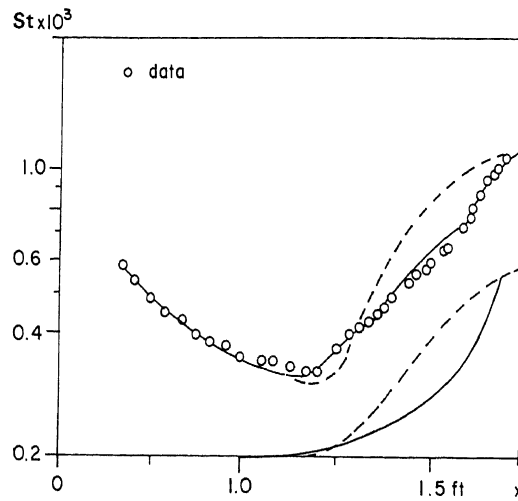

Figure 7. An example of Kuhn's (1971) prediction of Stanton number (St) data on a sharp-leading-edge flat plate at a Mach number of 6.18 utilising two intermittency distributions as reported in his figure 11; unit Reynolds number for this flow is $1.32 \times 10^6/\text{ft}$. The intermittency distribution (22) and the prediction based on it are shown by broken lines. Full lines correspond to his prediction that is matched with the experimental data on St ; the intermittency distribution thus inferred is considered by Kuhn as the experimental data.

experimental data of Schubauer (1939) on an ellipse at low speed, and of Coles (1954) on a flat plate at $M = 1.97$, demonstrate reasonable agreement and emphasize the necessity for modelling the transition zone. This model is among the most self-contained available at present, in that it includes a method for prediction of Re_{xt} as well.

4.5 Gaugler (1985)

This method, based on the STAN5 code of Crawford & Kays (1976), requires both the onset and extent of transition to be specified; the intermittency distribution is that of Abu-Ghannam & Shaw (1980), who have proposed the relation

$$\gamma = 1 - \exp(-5\xi_{AS}^3),$$

where

$$\xi_{AS} = (x - x_s)/(x_e - x_s) \quad \text{or} \quad (U - U_s)/(U_e - U_s), \quad (25)$$

depending on whether γ is measured along x at a given U (first definition) or at a fixed x with change in tunnel speed (second definition); suffixes s and e denote the start and end of transition. This intermittency model requires a length scale that is based on the asymptotic values (0 and 1 at the start and end respectively) of the intermittency distribution, and so is difficult to prescribe (Fraser *et al* 1988). Gaugler matched his predictions with experimental data from various sources, obtaining both onset and extent by trial and error. An interesting feature of his results for heat transfer is that $x(\gamma = 0^+)$ is always upstream of x_{\min} , in agreement with the data of Narasimha (1958), Owen (1970) and Suder *et al* (1988).

4.6 Michel *et al* (1985)

The Reynolds stress in this prediction scheme is also slowly turned on in the transition zone. However, the intermittency distribution (10) is abandoned in favour of a new expression

$$\gamma = 1 - \exp[-0.45(\theta/\theta_t - 1)^2]. \quad (26)$$

Michel *et al* note that predictions made on this basis show respectively an unduly slow variation of H and an underprediction of C_f , towards the end of the transition zone. The predictions were, however, considerably improved by adopting a distribution with an overshoot above unity in the later part of the transition zone (figure 8). Although Michel *et al* justify the overshoot from a consideration of the Reynolds stress, an intermittency higher than unity is physically meaningless, and must be taken as an indication of internal inconsistency in the model. Interestingly, Michel *et al* find it necessary to use the overshooting γ -distribution to predict their own experimental data, which Arnal (1986) had earlier predicted using the distribution (10) and the integral method mentioned in §3.4.

4.7 Krishnamoorthy (1986) and Krishnamoorthy *et al* (1987)

An extension of the Patankar-Spalding (1970) method with the γ -distribution (3) is utilised by Krishnamoorthy for predicting his heat-transfer measurements on turbine blades and nozzle guide vanes. In general, the onset of transition was taken from the measured heat-transfer distribution, and the extent was selected to obtain the best agreement. For pressure surfaces, the onset is also considered by Krishnamoorthy to correspond to the location at which measurements begin to deviate from the predicted laminar values; λ is taken as 0.24 times the chord length.

Krishnamoorthy finds that the Patankar-Spalding (1970) relation for the mixing-length used (in estimating v_T) overpredicts his measured heat transfer rates both during transition and in the fully turbulent regimes. The use of a Van Driest type damping factor for the viscous sub-layer, however, was found to considerably improve predictions.

For predicting flows at relatively high turbulence levels, Krishnamoorthy assumes an effective total diffusivity

$$\bar{v} = v + \gamma v_T + v_p, \quad (27)$$

where v_p takes into account the effect of free-stream turbulence, and is prescribed as a function of its intensity and length scale. Agreement with experimental data seems to be better with the use of (27) than that with (19).

Krishnamoorthy *et al* (1987) have extended (27) for predicting Krishnamoorthy's data on nozzle guide vanes. The onset is assumed to correspond to $Re_{\theta_i} = 160$, and the extent is given by a modification of (5) to include the effect of pressure gradients,

$$Re_x = 5 Re_{x_i}^{0.8} [1 + 2.5 \times 10^6 K_1], \quad (28)$$

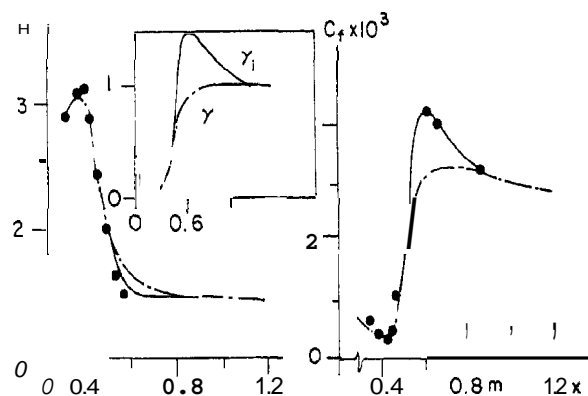

Figure 8. Variations of the shape factor (H) and skin-friction coefficient (C_f) as predicted by Michel *et al* (1985) with and without overshoot in the intermittency distribution: γ_i denotes the overshooting intermittency; filled symbols are the measurements of these authors.

where $K_1 (= \nu U'/U^2)$ is a pressure gradient parameter. Predictions are in qualitative agreement with the data.

5. Differential models

These models also directly tackle the Reynolds-averaged equations of motion with either one- or two-equation turbulence closure models. The former postulates a turbulent kinetic energy equation, which in essence determines a velocity scale. The basic argument behind two-equation models is that, in addition to a velocity scale, a separate equation for a length scale is also necessary. Such an equation has for example been proposed by Ng & Spalding (1972), who put $\nu_T = \text{const.} K^{1/2} L_A$, where K and L_A denote the turbulent kinetic energy and length scale respectively. Partial differential equations are then devised for K as well as KL_A , although the dynamics governing the length scale is obscure (Narasimha 1983). Instead of an equation for a length scale, Saffman (1970) proposes one for pseudo-vorticity, which may be considered the reciprocal of a time scale. Perhaps the most widely used two-equation model is the so called 'K- ϵ ' (turbulent kinetic energy-dissipation rate) model discussed by Jones & Launder (1972, 1973) and Launder *et al* (1973).

Although the prediction of boundary layer parameters in these models does not require any specific definitions of the beginning and end of transition, the range over which the turbulent energy increases from initially low values to the final turbulent values can be considered to correspond to the transition zone (e.g., Wilcox 1975). For triggering transition, however, these models require some initial disturbance, e.g., in terms of an initial profile of turbulent energy as in Wilcox (1981) or a source term in the energy equation as in McDonald & Fish (1973).

5.1 McDonald & Fish (1973)

The model of McDonald & Fish for plane compressible flow assumes a one-parameter mixing length profile normal to the wall; the streamwise development of this profile is computed using an integral form of the turbulence kinetic energy equation. This equation contains a source term through which free-stream turbulence may be introduced to start the transition process. The onset of transition is considered to correspond to the minimum in the skin friction distribution. For the data of Schubauer & Klebanoff (1955), who measured the intermittency distribution in the transition zone, a higher free-stream turbulence level than quoted in the experiment was necessary in order to initiate transition at the experimentally observed point. Reasonable agreement with experimental data is obtained at free-stream turbulence levels upto 3%. However, it is not clear how other triggers for transition, such as surface vibrations or roughness, can be taken into account. The variation of zone-length Reynolds number with onset Reynolds number is weaker than that implied by the Dhawan-Narasimha correlation (5). Free-stream turbulence levels actually used for predicting the measurements of heat-transfer rates on turbine blades by Turner (1971) differed by $\pm 30\%$ from those quoted by Turner. These differences, however, are considered by McDonald & Fish to be insignificant in view of the uncertainty in their inference of free-stream velocity and of the inherent error in the measurements of free-stream turbulence intensity. These authors also point out the sensitivity of the prediction scheme to the imposed pressure distribution on the surface.

5.2 Blair & Werle (1980, 1981)

This scheme is mainly an extension of the turbulence models of McDonald & Kreskovsky (1974) and McDonald & Fish (1973). Blair & Werle in general prefer the former; it appears from their (1980) analyses of their own constant-pressure data that the two models are comparable in performance, but that the second is marginally better than the first (referred to as the BW Model 1 hereafter) at high free-stream turbulence levels. Heat transfer distributions are predicted better for zero than for non-zero pressure gradient flows, although both models fail on the constant-pressure heat transfer measurements at $q = 0.25$. Extensive comparisons of these measurements and models have been carried out by Dey & Narasimha (1989a) with their linear-combination type integral model, and will be discussed in §6.

5.3 Wilcox (1981)

Wilcox utilises the linear stability solutions at the e^4 -amplification point to model a key closure coefficient in his turbulence model, and to provide initial profiles for the turbulent energy and its dissipation rate. Unlike McDonald & Fish (1973), Wilcox does not report any boundary layer parameters although it should not be difficult to calculate them. The applicability of this method to flows at high q and with pressure gradient cannot yet be assessed, as comparisons are provided only with the constant-pressure data of Schubauer & Skramstad (1948) for a relatively low free-stream turbulence level ($q \leq 0.2$).

5.4 Arad *et al* (1982, 1983)

In these papers, which cover compressible, axisymmetric flows, Ng's (1971) two-equation turbulence model is modified and incorporated in the Patankar–Spalding (1970) computational scheme. Additional empirical constants are introduced by Arad *et al* (1982) to improve predictions at low turbulence levels. Arad *et al* (1983), however, find that, in order to obtain any agreement with the experiments of Meier & Kreplin (1980) on transition in the boundary layer on a body of revolution, the numerical constants in the model need to be adjusted, as the experimental length scale was seven times the computed value.

5.5 Vancoillie (1984)

A modification of the K - ϵ equations of Jones & Launder (1973) is used by Vancoillie for computing transitional flows. Conditional averages of all quantities for intermittent flow are introduced, leading to mass and momentum equations for each of the corresponding velocity fields; these are supplemented by equations for K and ϵ . All these equations, with the exception of continuity for the conditionally laminar flow, involve the transitional intermittency, which is taken to be given by (3). Reasonable agreement is shown with the experiments of Schubauer & Klebanoff (1955) and Arnal & Juillen (1977) on a flat plate, and of Blair & Werle (1981) in favourable pressure gradients.

5.6 Wang *et al* (1985)

Boundary layer parameters including heat-transfer rates are predicted by Wang *et al*

incorporating the low Reynolds number version of the K - E model of Jones & Launder (1972, 1973) in the STAN5 code of Crawford & Kays (1976). Wang *et al* find that for turbine blades, the boundary conditions for K and E near the leading edge are important, and they propose a technique for providing them. Although their predictions "agreed favorably" with the measurements considered by them, they also note discrepancies in the transitional and fully turbulent regions on the suction surface.

5.7 Krishnamoorthy *et al* (1987)

Krishnamoorthy's (1986) measurements of heat-transfer rates on turbine nozzle guide vanes are predicted by these authors using the K - E model of Jones & Launder (1973), with a change in one of the constants associated with the model (TR Shembharkar, private discussion). Of the various measurements at different free-stream turbulence levels (1.6, 3.6, 7.3 and 12.7%) considered by Krishnamoorthy *et al*, calculations downstream of the predicted laminar separation point were not carried out by them for flows at turbulence levels 1.6 and 3.6%. Underpredictions of heat-transfer rate near the trailing edge are attributed to separation of the flow in the region. Agreement is found to be "not satisfactory" on pressure surfaces. It may be noted that their eddy diffusivity model (27) discussed in §4.7 predicts these measurements better than their differential model.

6. Assessment

As of today, it has not been possible to solve the Navier–Stokes equations in the transition zone, and this may remain so for many years to come. Numerical solutions, which have so far been confined to such simple geometries as a channel, have not yet produced encouraging pictures of turbulent spots and the transition zone on a flat plate.

To provide estimates for engineering applications, it has been necessary to resort to modelling. A large number of algebraic and differential models have been proposed, whereas integral models based on the linear-combination principle are few. The differential models are more complex in the sense that they involve several partial differential equations, whose solution furthermore does not seem to be straightforward in all flows (as can be inferred from Arad *et al* 1982, 1983, Wang *et al* 1985 and Krishnamoorthy *et al* 1987, for example). The choice of an appropriate closure model is also important, but remains difficult, as can be illustrated by the analyses of Tanaka *et al* (1982) and Tanaka & Yabuki (1986). These authors, who have undertaken measurements in flows first undergoing relaminarization and then retransition to a turbulent state in a constant area duct, calculate the flow using the $K - KL_A$ model of Rotta (1951, 1972) and incorporating modifications suggested by Kawamura (1979) for low Reynolds number effects. Comparisons reveal that while the heat transfer distribution is predicted reasonably well for retransition over a short region in the constant area duct, the skin friction is not. Tanaka & Yabuki (1986) therefore suggest that a careful choice of the turbulence model is necessary in such flows. Also, Tanaka *et al* (1982) find that their scheme is better than the K - E model of Jones & Launder (1972) which was seen to overpredict the measured dip in the heat transfer distribution (figure 9). Tanaka *et al* (1982), however, do not rule out the

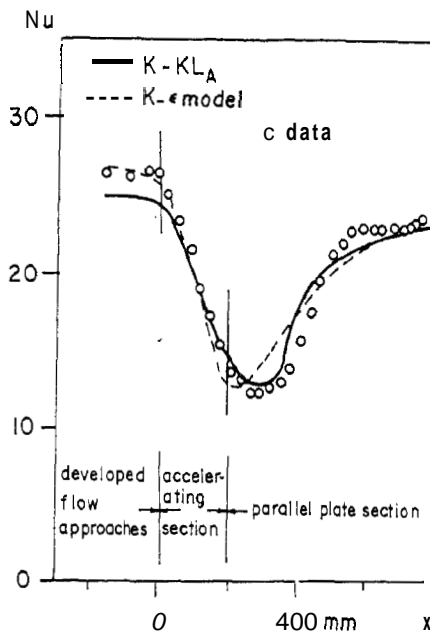

Figure 9. Comparison reported by Tanaka *et al* (1982) between their $K-KL_A$ model and the $K-\epsilon$ model of Jones & Launder (1972). Measurements (open symbols) of Nusselt number (Nu) by Tanaka *et al* (1982) were made in a flow that first relaminarizes, and then undergoes re-transition in a constant-area duct.

possibility of improving the performance of the $K-\epsilon$ model by optimising the associated constants. Two-equation models in particular are gaining popularity, but their value is still to be demonstrated. As Simoneau *et al* (1988) comment, these models are sensitive to the initial conditions, and the turbulence production term remains a key unknown; they seem only to 'mimic' the physics rather than contain it.

For engineering calculations, computational speed, simplicity and accuracy are important. However, it is paradoxical that while differential (and higher order) models are being developed, simple integral models seem to have received less emphasis, although they are attractive and especially appropriate for engineering design. Indeed, "the simpler and the more sophisticated methods are complementary" (Cousteix 1982), and in turbulent flows, integral methods are known to perform well (see Kline *et al* 1968, Green *et al* 1973). Furthermore, integral methods require data that are easier to obtain and are far more abundant (Cousteix 1982) than those demanded by differential models.

An authentic evaluation of various models remains rather difficult, as comprehensive data of the type required for such comparisons are still scarce. (At the least, such data should include mean velocity, the Reynolds stresses, surface parameters and the intermittency, as well as a specification of the disturbance environment.) Nevertheless, the only available comparison between a linear-combination type integral model and the differential models (Dey & Narasimha 1989a) reveals some interesting results. An adequate representation of the transition zone is possible by the linear-combination principle, which is at least as good as the differential models (figure 10), and in some cases better than them (figures 11a, b). Both linear-combination and algebraic models, however, require a prescription for obtaining the onset location and the extent of the transition zone. The prediction of the former is still an open problem, and considerable effort is being made towards developing various correlations (Abu-Ghannam & Shaw 1980, Govindarajan & Narasimha 1989, for example) as well as more elaborate methods involving flow

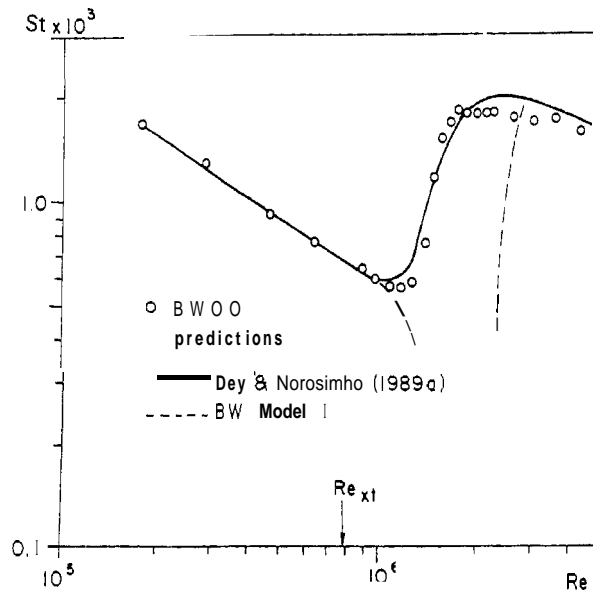

Figure 10. An example of Dey & Narasimha's comparison of their linear-combination results with the prediction (BW Model I) and measurements of Stanton number (St) by Blair & Werle (1980). The code BWO0 corresponds to Blair & Werle's constant-pressure flow without any grid (at a free-stream turbulence level of 0.25%). BW Model I is a differential type.

instability (see e.g. Bushnell *et al* 1988). The extent is connected closely with the breakdown rate, which appears to be best specified via the non-dimensional parameter N . In fact, the proposals of Dey & Narasimha (1989c) and Gostelow (1989) on N now offer more refined estimates of the extent of the transition zone in both zero and non-zero pressure gradient flows (figure 12).

7. Conclusion

Models based on the linear-combination principle show great promise for predicting

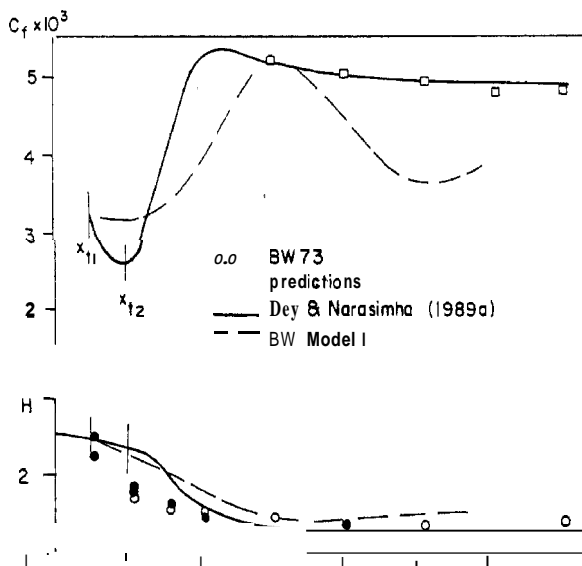

Figure 11a. Blair & Werle's (1981) measurements on C_f and H in favourable pressure gradient as predicted by them (BW Model I) and Dey & Narasimha; flow BW73 corresponds to Blair & Werle's measurements at $K_1 = 0.75 \times 10^{-6}$

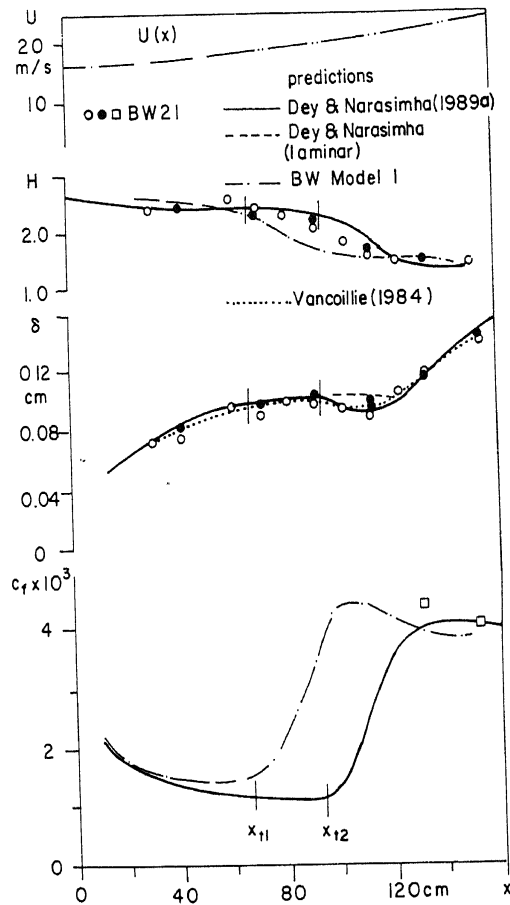

Figure 11b. An example of Dey & Narasimha's comparison of their linear-combination type integral model with the differential model (BW Model 1) of Blair & Werle (1981) and that of Vancoillie (1984) against the measurements (symbols) of Blair & Werle. BW21 corresponds to Blair & Werle's measurements at $K_1 = 0.2 \times 10^{-6}$ with grid 1.

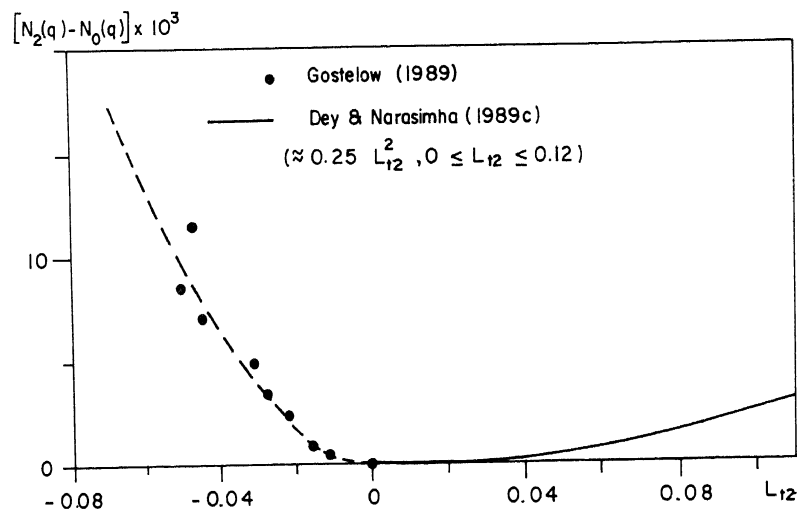

Figure 12. Variation of the quantity $[N_2(q) - N_0(q)]$ with the pressure gradient parameter L_{12} in both favourable and adverse pressure gradients, based on the data of Gostelow (1989) and the proposal of Dey & Narasimha (1989c); L_{12} is the value of the pressure gradient parameter L at the station x_{12} .

the flow in the intermittent transition zone in **2-D** boundary layers. Algebraic and differential models seem to need further development before they can handle flows in high pressure gradients. The prediction of onset, and in particular of the location of sub-transitions when they occur, remain difficult problems. Comprehensive experimental data are still needed. Scarcely a beginning has yet been made in **3-D** flows, which now require considerably more attention.

The authors wish to express their appreciation to Prof. A Prabhu for support through the project 'Transition and turbulence in shear flows' sponsored by the Department of Science and Technology.

List of symbols

C_f	skin-friction coefficient;
$F(\gamma)$	the quantity $[-\ln(1-\gamma)]^{1/2}$;
H	boundary layer shape factor, $=\delta^*/\theta$;
K	turbulent kinetic energy;
K_1	a pressure gradient parameter, $\equiv (v/U^2)dU/dx$;
l	a transition zone length, $=x_{\max} - x_{\min}$;
L	a pressure gradient parameter based on the momentum thickness for laminar layer, $=(\theta_L^2/\nu)dU/dx$;
L_i	L at x_i ;
L_{i2}	L at x_{i2} ;
L_A	length scale of turbulence fluctuation;
M	Mach number;
n	spot formation rate per unit time and spanwise distance;
\hat{n}	non-dimensional spot formation rate;
N	non-dimensional spot formation rate in terms of the boundary layer thickness at the onset of transition;
N_2	non-dimensional spot formation rate in terms of the boundary layer thickness at the origin of the turbulent boundary layer in pressure gradients;
N_0	value of N at a free-stream turbulence level corresponding to that for N_2 , but without a pressure gradient;
Nu	Nusselt number;
q	free-stream turbulence intensity (%);
q_0	equivalent free-stream turbulence for residual disturbances associated with a given facility;
r	body radius in an axisymmetric geometry;
Re	Reynolds number;
St	Stanton number;
t	time;
u	boundary layer velocity;
U	free-stream velocity;
x	streamwise coordinate;
\bar{x}	x at $\gamma = 0.5$;

x_t	the onset location in constant pressure, obtained by extrapolating the best linear variation of $F(\gamma)$ with x to $F(\gamma) = 0$;
x_{t1}	the onset location in pressure gradients, obtained by extrapolating the best linear variation of $F(\gamma)$ with x to $F(\gamma) = 0$ as in figure 5;
x_{t2}	a virtual onset location derived from extrapolation to $F(\gamma) = 0$ of data after subtransition, as in figure 5; also the virtual origin of the turbulent boundary layer in pressure gradient;
x^*	the streamwise location corresponding to the 'kink' in the $F(\gamma)$ plot in figure 5;
x step	the streamwise location at which the lag-entrainment scheme for turbulent boundary layer becomes effective, as in figure 4;
y	coordinate normal to x ;
α	spot spread angle;
γ	transitional intermittency;
δ	boundary layer thickness;
δ^*	boundary layer displacement thickness;
ε	turbulent kinetic-energy dissipation rate;
λ	a transition zone length, $= x(\gamma = 0.75) - x(\gamma = 0.25)$;
λ_1, λ_2	transition zone length parameters in pressure gradient, defined in figure 5;
λ_{CT}	a transition zone length, $= x(\gamma = 0.95) - x(\gamma = 0.0)$;
λ_k	a transition zone length in (22);
ν	kinematic viscosity;
ν_T	eddy diffusivity;
$\bar{\nu}$	effective total diffusivity;
ν_p	additional term in $\bar{\nu}$ to take account of the effect of high free-stream turbulence, as in (27);
ξ	$(x - x_t)/\lambda$;
ξ_{AS}	non-dimensional scale in (25);
η	$(x - \bar{x})/\sigma_s$;
θ	boundary layer momentum thickness;
θ_t	θ_L at x_t ;
σ	non-dimensional spot propagation parameter in constant pressure;
σ_s	standard deviation of intermittency distribution.

Subscripts

Y_L, Y_T	values of Y in laminar and turbulent flows respectively;
Y_s, Y_e	values of Y at beginning and end of transition respectively corresponding to $\gamma = 0$ and 1 in (25);
Y_{\min}, Y_{\max}	values of Y corresponding to the minimum and maximum respectively in the measured distribution of surface parameters (e.g. Pitot pressure, skin friction etc.);
Y_λ	value of Y based on λ ;
Y_{x_t}, Y_{x_b}	values of Y at x_t and x_b respectively;
Y_{θ_t}	value of Y based on θ_t ;
Y_{σ_s}	value of Y based on σ_s ;
$Y_{\sigma_s 0}$	value of Y_{σ_s} in constant-pressure;
Y_y	value of Y based on the distance to the origin of the turbulent boundary layer;

Y_0 Y at constant-pressure;
 Y_{lk} value of Y based on l_k .

References

- Abu-Ghannam B J, Shaw R 1980 *J. Mech. Eng. Sci.* 22 213-228
- Adams J C Jr 1972 *AIAA J.* 10: 841-843
- Arad E, Berger M, Israeli M, Wolfshtein M 1982 *Int. J. Numer. Methods Fluids* 2 1-23
- Arad E, Israeli M, Wolfshtein M 1983 Proc. 8th Aust. Fluid Mech. Confc.
- Arnald D 1986 Three-dimensional boundary layers: laminar-turbulent transition AGARD-FDP-VKI Cours special, April
- Arnald D, Juillen J C 1977 *La Recherche Aerosp.* 2: 75-88
- Batchelor G K 1950 *J. Aeronaut. Sci.* 17 441-445
- Blair M F 1988 By-pass mode boundary layer transition in accelerating flows (private communication)
- Blair M F, Werle M J 1980 The influence of free-stream turbulence on the zero pressure gradient fully turbulent boundary layer, UTRC Report R80-914388-12, United Technologies Research Center, Connecticut
- Blair M F, Werle M J 1981 Combined influence of free-stream turbulence and favourable pressure gradients on boundary layer transition and heat transfer, UTRC Report R81-914388-17, United Technologies Research Center, Connecticut
- Bradshaw P (ed.) 1976 *Turbulence* (New York: Springer-Verlag)
- Brown A, Burton R C 1978 *ASME J. Eng. Power* 100: 159-168
- Bushnell D M, Malik M R, Harvey W D 1988 In: *Proceedings IUTAM Symp. Transsonic III* (Gottingen: IUTAM)
- Cantwell B, Coles D, Dimotakis P 1978 *J. Fluid Mech.* 87 641-672
- Cebeci T (ed.) 1983 *Numerical and physical aspects of aerodynamic flows I* (New York: Springer-Verlag)
- Cebeci T, Smith A M O 1974 *Analysis of turbulent boundary layers* (Academic Press)
- Chen K K, Thyson N A 1971 *AIAA J.* 5: 821-825
- Coles D 1954 *J. Aeronaut. Sci.* 21: 433-448
- Coles D 1968 In: *Proc. Computation of Turbulent Boundary layers - 1968* (eds J S J Kline, M V Morkovin, G Sovran, D J Cockrell, AFOSR-IEP-Stanford Conference)
- Coosteix J 1982 Proc. 1980-81 AFOSR-HTTM-Stanford Conf. *Complex turbulent flows*, (eds J S J Kline, B Cantwell, Lilley, pp. 650-671)
- Crawford M E, Kays W M 1976 STAN5 - A program for numerical computation of two-dimensional internal and external boundary layer flows, NASA CR 2742
- Dey J 1988 *An integral method for the calculation of 2-D transitional boundary layers*, PhD thesis, Indian Institute of Science, Bangalore
- Dey J, Narasimha R 1989a *J. Aircr.* (in press)
- Dey J, Narasimha R 1989b *J. Indian Inst. Sci.* (in press)
- Dey J, Narasimha R 1989c *Exp. Thermal Fluid Sci.* (to appear)
- Dhawan S, Narasimha R 1958 *J. Fluid Mech.* 3: 418-436
- Emmons H W 1951 *J. Aeronaut. Sci.* 18: 490-498
- Eppler R, Fasel H (eds) 1980 *Laminar-turbulent transition* (Proc. IUTAM Symp., Stuttgart 1979) (Berlin: Springer-Verlag)
- Fischer M C 1970 An experimental investigation of boundary-layer transition on a 10° half-angle cone at Mach 6.9, NASA TN D-5766
- Fraser C J, Milne J S 1986 *Proc. Inst. Mech. Eng.* 200: 179-187
- Fraser C J, Milne J S, Gardiner I D 1988 *Proc. Inst. Mech. Eng.* 202 195-203
- Gaugler R E 1985 A review and analysis of boundary layer transition data for turbine application, NASA TM 86880
- Glezer A, Katz Y, Wagnanski I 1989 *J. Fluid Mech.* 198 1-26
- Goldstein S 1938 *Modern developments in fluid dynamics* (Oxford Univ. Press)
- Gong L, Ko W L, Quinn R D 1984 Thermal response of space-shuttle wing during reentry heating, AIAA Paper No. 84-1761
- Gostelow J P 1989 Pre-print of the paper to be presented at 9th International Symp. on Air-breathing Engines (Athens, Greece) in Sept. '89

- Govindarajan R, Narasimha R 1989 The role of residual non-turbulent disturbances on transition onset in two-dimensional boundary layers, NAL TM DU 8901, National Aeronautical Laboratory, Bangalore
- Green J E, Weeks D J, Brooman J W F 1973 Prediction of turbulent boundary layers and wakes in compressible flow by a lag-entrainment method, RAE Technical Report 72231, Farnborough
- Gutmark E, Blackwelder R F 1987 *Exp. Fluids* 5: 217-229
- Harris J E 1970 *Numerical solution of the compressible laminar, transitional and turbulent boundary layer equations with comparisons to experimental data*, PhD thesis, Virginia Polytechnic Institute
- Harris J E 1971 Numerical solutions of equations for compressible laminar, transitional and turbulent boundary layers and comparisons with experimental data, NASA Tech. Report R-368
- Herbert T 1988 *Annu. Rev. Fluid Mech.* 20: 487-526
- Jones W P, Launder B E 1972 *Int. J. Heat Mass Transfer* 15: 301-314
- Jones W P, Launder B E 1973 *Int. J. Heat Mass Transfer* 16: 1119-1130
- Kachanov S Yu, Levchenko V Ya 1984 *J. Fluid Mech.* 138: 209-247
- Kawamura H 1979 *Proc. 2nd Symp. Turbulent Shear Flows* (London) pp. 18.16-18.21
- Klebanoff P S, Tidstrom K D, Sargent L M 1962 *J. Fluid Mech.* 12: 1-34
- Kline S J, Morkovin M V, Sovran G, Cockrell D J (eds) 1968 *Proc. Computation of Turbulent Boundary Layers - 1968*, AFOSR-IEP-Stanford Conference
- Kozlov V V (ed.) 1985 *Proc. 2nd IUTAM Symp. Laminar-Turbulent Transition* (Berlin: Springer-Verlag)
- Krishnamoorthy V 1986 *Effect of free-stream turbulence on the convective heat transfer to gas turbine blades*, PhD thesis, Indian Institute of Technology, Bombay
- Krishnamoorthy V, Shembharkar T R, Pai B R 1987 *Proc. Natl. Heat and Mass Transfer Conf.* (Bangalore: Indian Institute of Science)
- Kuhn G D 1971 Calculation of compressible, nonadiabatic boundary layers in laminar, transitional and turbulent flow by the method of integral relations, NASA CR-1797
- Lakshminarayana L 1976 Flight heat transfer to a nose cone, Report 76 FM 14, Aero. Eng. Dept., Indian Institute of Science, Bangalore
- Launder B E 1989 Phenomenological modelling. In: *Whither turbulence* (ed.) J Lumley (to be published)
- Launder B E, Morse A, Rodi W, Spalding D B 1973 NASA SP-321: 361-422
- Laurien E, Kleiser L 1989 *J. Fluid Mech.* 199: 403-440
- Lees L 1956 *Jet Propul.* 26: 259-269, 274
- Masaki M, Yakura J K 1969 *J. Spacecr. Rockets* 6: 1048-1053
- McDonald H, Fish R W 1973 *Int. J. Heat Mass Transfer* 16: 1729-1744
- McDonald H, Kreskovsky J P 1974 *Int. J. Heat Mass Transfer* 17: 705-716
- Meier H V, Kreplin H P 1980 *Z. Flugwiss. Weltraumforsch.* 4: 65-71
- Michel R, Coustols E, Arnal D 1985 *Proc. 3rd Symp. Numerical and Physical Aspects of Aerodynamic Flows*, 1985, (ed.) T Cebeci (California State University)
- Morkovin M 1969 *Viscous drag reduction* (ed.) C S Wells (New York: Plenum)
- Narasimha R 1957 *J. Aeronaut. Sci.* 24: 711-712
- Narasimha R 1958 *A study of transition from laminar to turbulent flow in the boundary layer of a flat plate*, AIISc thesis, Indian Institute of Science, Bangalore
- Narasimha R 1983 *J. Indian Inst. Sci.* A64: 1-59
- Narasimha R 1985 *Prog. Aerosp. Sci.* 22: 29-80
- Narasimha R 1989 Turbulence at the cross-roads: The utility and drawbacks of traditional approaches. In: *Whither turbulence* (ed.) J Lumley (Springer-Verlag) (to be published)
- Narasimha R, Devasia K J, Gururani G, Badri Narayanan M A 1984 *Exp. Fluids* 2: 171-176
- Narasimha R, Dey J 1983 Transitional intermittency data in plane and axisymmetric boundary layers, Report 83 FM 4, Aero. Eng. Dept., Indian Institute of Science, Bangalore
- Narasimha R, Dey J 1985 *Proc. 3rd Symp. Numerical and Physical Aspects of Aerodynamic Flows* (ed.) T Cebeci (Berlin: Springer-Verlag) pp. 57-74
- Ng K H 1971 *Prediction of turbulent boundary layer development using a two-equation model of turbulence*, PhD thesis, London University
- Ng K H, Spalding D B 1972 *Phys. Fluids* 15: 20-30
- Orszag S A, Patera A T 1983 *J. Fluid Mech.* 128: 347-385
- Owen F K 1970 *AIAA J.* 8: 518-523
- Owen F K, Horstman C C 1972 *AIAA J.* 10: 769-775
- Patankar S V, Spalding D B 1970 *Heat and mass transfer in boundary layers*, 2nd edn. (London: Intertext)
- Pohlhausen K 1921 *Z. Angew. Math. Mech.* 1: 252-268
- Priddy W J, Bayley F J 1985 *Int. J. Heat Fluid Flow* 6: 181-192

- Rotta J C 1951 *Z. Phys.* 129: 547-572
- Rotta J C 1972 *Turbulente Strömungen* (Stuttgart: Teubner)
- Rosenhead L (ed.) 1963 *Laminar boundary layers* (Oxford: Clarendon)
- Rouse H 1945 *J. Aeronaut. Sci.* 12: 429-431
- Saffman P G 1970 *Proc. R. Soc. London A*317: 417-433
- Saric W S, Thomas A S W 1984 *Proc. IUTAM Symp. Turbulence and Chaotic Phenomena in Fluids (Kyoto)* (ed.) T Tatsumi (Amsterdam: North-Holland)
- Schubauer G B 1939 Airflow in the boundary layer of an elliptical cylinder, NACA report 652
- Schubauer G B, Klebanoff P S 1955 Contributions on the mechanics of boundary-layer transition, NACA TN 3489
- Schubauer G B, Skramstad H K 1948 Laminar-boundary-layer oscillations and transition on a flat plate, NACA Report 909
- Sharma O P, Wells R A, Schlinker R A, Bailey D A 1982 *ASME J. Eng. Power* 104: 698-706
- Simoneau R J, Hendricks R C, Gladden H J 1988 *Proc. ASME Natl. Heat Transfer Conf. (Houston)* (ed.) H Jacobs, pp. 1-22
- Spence D A 1961 The growth of compressible turbulent boundary layers on isothermal and adiabatic walls, ARC RM 3191
- Suder K L, O'Brien J E, Reshotko E 1988 Experimental study of bypass transition on a boundary layer, NASA TM 100913
- Tanaka H, Kawamura H, Tateno A, Hatamiya S 1982 *ASME J. Heat Transfer* 104: 363-371
- Tanaka H, Yabuki H 1986 *ASME J. Fluids Eng.* 108: 325-330
- Tani I 1969 *Annu. Rev. Fluid Mech.* 1: 169-196
- Thwaites B 1949 *Aeronaut. Q.* 1: 245-280
- Townsend A A 1956 *The structure of turbulent shear flow* (Cambridge Univ. Press)
- Turner A B 1971 *J. Mech. Eng. Sci.* 13: 1-12
- Vancoillie G 1984 In: *Proc. 2nd IUTAM Symp. Laminar-Turbulent Transition* (Berlin: Springer-Verlag)
- Walker G J, Gostelow J P 1989 Effects of adverse pressure gradients on the nature and length of boundary layer transition, pre-print of the paper presented at ASME Gas Turbine Conf. (Toronto), June '89
- Wang J H, Jen H F, Hartel E O 1985 *ASME J. Eng. Gas Turbines Power* 107: 60-67
- Wray A, Hussaini M Y 1984 *Proc. R. Soc. London A*392: 373-389
- Wilcox D C 1975 *AIAA J.* 13: 241-243
- Wilcox D C 1981 *AIAA J.* 19: 56-64
- Wynanski I, Sokolov M, Friedman D 1976 *J. Fluid Mech.* 78: 785-819
- Zakkay V, Bos A, Jensen P F Jr 1966 AIAA Paper No. 66-493